

# Proceedings Book : 6th International Scientific Conference "Contemporary Kinesiology" : Split, August 25-27, 2017

---

## Other document types / Ostale vrste dokumenata

Publication year / Godina izdavanja: **2017**

Permanent link / Trajna poveznica: <https://urn.nsk.hr/urn:nbn:hr:221:881775>

Rights / Prava: [In copyright](#)/[Zaštićeno autorskim pravom.](#)

Download date / Datum preuzimanja: **2024-09-21**



Repository / Repozitorij:

[Repository of Faculty of Kinesiology, University of Split](#)



6<sup>TH</sup>  
INTERNATIONAL  
SCIENTIFIC  
CONFERENCE  
MEĐUNARODNI  
ZNASTVENI  
KONGRES

CONTEMPORARY  
KINESIOLOGY  
SUVREMENA  
KINEZILOGIJA

.....  
*Split, August 25-27, 2017*

# PROCEEDINGS BOOK



[conference.kifst.hr](http://conference.kifst.hr)

 KINEZIOLOŠKI  
FAKULTET  
SPLIT

**PROCEEDINGS BOOK**  
**6<sup>TH</sup> INTERNATIONAL SCIENTIFIC CONFERENCE**  
**„CONTEMPORARY KINESIOLOGY“**

**Publisher:** Faculty of Kinesiology, University of Split, Croatia

**Graphic design:** Dalmatina tisak d.o.o.

**Editors:** Zoran Grgantov  
Jelena Paušić  
Dražen Čular  
Marko Erceg  
Ana Kezić  
Mirjana Milić

**Scientific committee:** Antonio Dello Iacono, PhD (Israel)  
Stefan Walzel, PhD (Germany)  
Johnny Padulo, PhD (Italy)  
Antonino Bianco, PhD (Italy)  
Irena Valantine, PhD (Lithuania)  
Goran Kuvačić, PhD (Croatia)  
Saša Krstulović, PhD (Croatia)  
Alen Miletić, PhD (Croatia)  
Boris Milavić, PhD (Croatia)  
Igor Jelaska, PhD (Croatia)  
Sunčica Delaš Kalinski, PhD (Croatia)

**Organizing committee:** Rado Pišot, PhD (Slovenia)  
Dejan Madić, PhD (Serbia)  
Lenče Aleksovska Veličkovska, PhD (Macedonia)  
Milovan Bratić, PhD (Serbia)  
Saša Jakovljević, PhD (Serbia)  
Safet Kapo, PhD (Bosnia and Herzegovina)  
Stevo Popović, PhD (Montenegro)  
Goran Sporiš, PhD (Croatia)  
Ante Rađa, PhD (Croatia)  
Goran Kuvačić, PhD (Croatia)  
Marija Tina Haupmann (Croatia)

**In cooperation with:** Lithuanian Sports University  
Croatian Institute of Public Health  
Croatian Institute of Kinesiology and Sport  
Faculty of Economics University of Split  
The Academic College at Wingate  
University of Palermo

ISSN 1847-0149

*Authors are responsible for correct referencing and the language quality.*



6<sup>TH</sup> INTERNATIONAL  
SCIENTIFIC  
CONFERENCE

---

CONTEMPORARY  
KINESIOLOGY

---

*Split, August 25-27, 2017*

## CONTENTS

Stefan Walzel <b>Sport Performance Management – A mixed data driven approach.....</b>	<b>10</b>
Krunoslav Capak <b>Physical activity and non-communicable diseases.....</b>	<b>12</b>
Dino Mujkić <b>Athletes’ Dual Career / Support Young Talents.....</b>	<b>16</b>
Antonio Dello Iacono <b>Monitoring, interpreting, applying: a systematic field-based approach for training planning .....</b>	<b>18</b>
Derian D. Espinosa, Luis E. Rodríguez <b>Modification of pendulum test for elbow joint without additional normal used devises .....</b>	<b>23</b>
Slavica Žeger <b>Exercise in pregnancy and the postpartum period: perceptions, practices and recommendations .....</b>	<b>35</b>
Ana Penjak, Ivana Duran <b>Gender and Language: Assessing English Oral Skills within Sports-related Conference .....</b>	<b>47</b>
Tea Gutović, Boris Milavić, Zoran Grgantov <b>Qualitative Examination of Socio-Psychological Aspects Affecting Volleyball Setters Pre-Match Preparation .....</b>	<b>57</b>
Alessandra Tiloca PhD, Mafalda Orlando, Giovanni Monteleone <b>Spirometric Evaluation In Sitting Volley: A Pilot Study .....</b>	<b>77</b>
Maki Grle, Goran Vrgoč, Branka Matković, Ivana Grle, Goran Jelaska, Goran Sporiš <b>Effects of kinesiotherapy after conservative treatment of distal radius fracture: Home-based vs supervised physical therapy protocol .....</b>	<b>79</b>
Dusko Bjelica, Jovan Gardasevic, Ivan Vasiljevic, Stevo Popovic <b>Body Mass Index of athletes participating in football premier league in Montenegro .....</b>	<b>81</b>

Mila Vukadinović Jurišić, Dušan Rakonjac, Jelena Obradović <b>Effects of carbohydrate supplementation in combination with resistance training on morphological characteristics</b> .....	83
Antonijo Đerek, Boris Dugonjić <b>Impact of uniform repeated exercise on white blood cells count</b> .....	93
Duje Radman, Tea Bešlija, Mario Tomljanović <b>Injury incidence and severity in elite football players during one competitive season</b> .....	95
Mirko Tufegdžija, Ernest Šabić <b>Terrorism in Sports Arena</b> .....	102
Aleksandra Aleksić-Veljković, Kamenka Živčić Marković, Lucija Milčić, Marko Veljković, Marijo Možnik <b>The Influence of Anthropometry on the Balance Beam Performance of Young Gymnasts</b> .....	104
Tijana Šćepanović, Dragan Marinković, Dejan Madić, Branka Protić-Gava <b>Effects of 12-week corrective treatment on the postural status of younger school-age children</b> .....	115
Duje Petričević, Katija Kovačić <b>The indomitable rise of eSports and synergy prospects with classical sport forms and kinesiology</b> .....	123
Marina Kostović Papak, Katija Kovačić <sup>2</sup> , Duje Petričević <b>Comparing the legal framework of adventure tourism</b> .....	134
Milica Đukić, Dragoslav Jakonić, Milorad Đukić <b>Aerobic capacity of handball players with hearing impairment</b> .....	144
Željka Saratlija, Goran Jelaska, Goran Kuvačić <b>The effect of anthropological characteristics on the soldiers' efficacy in mastering the NATO obstacle polygon</b> .....	152
Josip Maleš, Toni Batinić, Dražen Guć <b>The Effect of Specialist Military Training on Morphological Characteristics of Navy Recruits</b> .....	162

Marijo Možnik, Lucija Milčić, Kamenka Živčić Marković	
<b>Motor Knowledge and Process of Learning Basic Gymnastic Elements in Students of Faculty of Kinesiology.....</b>	<b>167</b>
Špela Bogataj, Mateja Videmšek, Maja Bučar Pajek	
<b>Differences in selected motor abilities and physical characteristics among five to six year old boys and girls.....</b>	<b>178</b>
Hrvoje Sivrić, Boris Milavić, Marko Erceg	
<b>Psychological coping skills of student futsal players.....</b>	<b>186</b>
Ana Kezić, Đurđica Miletić, Nina Ivančić	
<b>Motor proficiency in the initial phase of learning rhythmic gymnastics skills.....</b>	<b>196</b>
Marko Lozančić, Tea Bešlija, Mario Tomljanović, Ante Jurić, Ivan Ćuković, Jakov Previšić	
<b>Using of GPS in football training .....</b>	<b>204</b>
Tea Bešlija, Dražen Čular, Daria Bilić, Mario Tomljanović, Nenad Stojiljković, Ljubomir Pavlović	
<b>Body Mass Manipulation in Taekwondo .....</b>	<b>210</b>
Darinka Korovljević, Zoran Milošević, Dejan Madić, Nebojša Maksimović	
<b>Differences in personality dimensions regarding the success in sport of the candidates for enrolment in the Faculty of Sport and Physical Education .....</b>	<b>218</b>
Diana Gluhak, Damir Zubac	
<b>Impact of dietary supplements in professional sports: a pilot study ....</b>	<b>228</b>
Arben Bici, Astrit Hafizi	
<b>Analysis of total distance covered by football player age 14-18 year old in a football match.....</b>	<b>231</b>
Nikola Jevtić, Borislav Obradović, Jelena Paušić, Sasa Radosav, Milan Pantović, Dragan Marinković, Aleksandar Karać	
<b>Changes in Isometric Endurance of the Lumbar Extensors in Children . . .</b>	<b>236</b>

Ana Gruica, Lucijana Krželj, Mia Mandić <b>Impact of Gender on Attitudes and Habits Towards Fitness and Recreation Among Croatian Actors.....</b>	<b>246</b>
Marijan-Frane Tomašić, Jelena Paušić <b>Core stability in baseball .....</b>	<b>254</b>
Miran Pehar, Ivan Zeljko, Damir Sekulić <b>Correlates of change-of-direction speed and reactive agility in basketball; playing-position- vs. total-sample approaches.....</b>	<b>264</b>
Ana Lozina, Andrija Tomić, Gorana Adum <b>Postural stability in older community-dwelling adults from Split.....</b>	<b>270</b>
Ante Jurić, Mario Tomljanović, Tea Bešlija <b>Relations Between Some Anthropometric Characteristics and Motor Abilities in Soccer Players .....</b>	<b>276</b>
Tihomir Vidranski, Zvonimir Tomac, Petar Otković <b>The application of the raising of the torso from a lying position test (MRSPTL) in 30 and 60 seconds in elementary school pupils .....</b>	<b>281</b>
Jakov Previšić, Tea Bešlija, Mario Tomljanović, Ante Jurić, Ivan Ćuković, Marko Lozančić <b>Using of GPS in football match.....</b>	<b>289</b>
Adriana Češnik <b>Preferences of high school students regarding enrollment at the Faculty of Kinesiology and other programmes of the University of Split.....</b>	<b>298</b>
Daniela Dimlić, Zoran Grgantov, Mirjana Milić, Boris Dugonjić <b>Metric characteristics of some agility tests on sand surface .....</b>	<b>304</b>
Antonio Župan <b>Relations of assessment of team cohesion and player positions among young soccer players .....</b>	<b>309</b>

## **INVITED LECTURES**



## **Sport Performance Management – A mixed data driven approach**

Stefan Walzel

*German Sport University Cologne*

The topic of sport performance management has gained a lot of attention over the last years. There are several approaches to measure and to manage performance in sports but so far there is no common understanding of one single and integrative approach to manage the performance of a sport organisation, in particular not in professional team sports, where I would like to focus on. The purpose of this research is to start with a conceptual approach by critically reflecting existing approaches in sports and in sports management and provide an idea what needs to be done in order to develop an integrative approach with the final objective to increase the sporting performance under the restriction of limited resources.

The performance construct is often described as a difficult one to understand with high complexities and a lot of interdependencies (MacLean, 2017). Looking at the variety of dimensions, e.g. results or outputs, inputs, time horizon, quality, input output relation, and human factors, they all demonstrate how complex and interrelated performance is (Gerhart, 2010; London & Mone, 2009; MacLean, 2001). Furthermore, no clear definition and understanding of performance management exist even in sport (Arnold et al., 2012; Thorpe & Holloway, 2008). The logic behind performance differs between sports and management tremendously. Often sports performance is measured by counting the number of medals, wins, championships etc., so the ultimate goal is win maximisation. In contradiction, management performance is based on criteria such as profit, market share, revenues etc. Comparing both concepts and looking for similarities, it becomes obvious there is only a very small part where both concepts have a common understanding of equal performance, e.g. when it comes to the qualification for the football champion's league. This means a football team has to achieve a certain sporting performance in order

to be qualified for the champion's league in order to benefit from the enormous sponsorship and media revenues. The question arises what has to be done in order to develop a more integrative and more common understanding of managing sports performance?

So far, the professional sport teams which are ranked top in the sporting league table are mostly the team with the highest expenses, but are these teams equally the most successful ones from a managerial perspective? A rational perspective on sport performance management in a holistic way is missing in the academic literature so far. Therefore, by introducing a conceptual and integrative approach for managing sports performance can increase the long term viability and sustainability of team sports by considering the specific features of sports. With the support of the technological advancements which are available today we must find out the relations between sporting criteria, management criteria and other criteria which have an influence on the overall performance of a professional team sport organization, e.g. weather. This study is just a starting point however with more research in this field we can maybe answer this question in the future: What makes Iceland with a population of 330,000 to one of the most successful team sport nations in Europe?

# Physical activity and non-communicable diseases

Krunoslav Capak

*Croatian Institute of Public Health (CIPH)*

## Introduction

Physical activity is an important factor for the promotion of health and disease prevention. Regular and moderate physical activity such as walking or cycling has significant benefits and can reduce the risk of non-communicable diseases. Nowadays non-communicable diseases are the leading cause of death in the world. The leading causes of death in 2015 in Croatia were circulatory diseases which together with neoplasms were accounted for three quarters of overall causes of mortality. However, NCDs are largely preventable by addressing key risk factors such as unhealthy diet and physical inactivity. According to the WHO, physical activity is the fourth leading factor of mortality which causes an estimated 3.2 million deaths worldwide.

The promotion of healthier life styles, including healthy eating and physical activity, the reduction of preventable health risks, and improvement of the quality of life are important tasks for the health system. Increasing the awareness and understanding of the impact of diet and physical activity on health as well as the development and implementation of global, regional, national policies and action plans to improve diets and increase physical activity can be best achieved through a multisectoral approach and the application of the health-in-all-policies principle.

As per WHO's Global Action Plan for the Prevention and Control of NCDs 2013-2020 a 10% relative reduction in prevalence of insufficient physical activity is one of the voluntary global targets for prevention and control of non-communicable diseases by 2025. The work presents data regarding physical activity and non-communicable diseases as well as some public health activities undertaken in Croatia.

## Materials and methods

Recent policy documents and research results discussing physical activity and health as well as non-communicable diseases were reviewed. Some information presented were collected upon CIPH inquiry to network of county public health institutes in Croatia about physical activity promotion projects and programs in June 2016.

## Results and discussion

Dietary risks, high blood pressure, smoking, high body mass index, alcohol use and physical inactivity are risk factors that account for the most disease burden in Croatia according to The Global Burden of Disease Study 2010.

As noted in the WHO's Global Action Plan for the Prevention and Control of NCDs 2013-2020, motivating people for more physical activity is one of the key strategies for reducing the burden of NCDs. Although the WHO also provides recommendations for the minimum amounts of activity for all age groups which could improve one's health, it is crucial to remember that some physical activity is always better than none. Inactive people should start with physical activity step-by-step, first with small amounts/low intensity, possible as part of their daily routine, and then gradually increase duration, frequency, and intensity.

WHO recommended levels of physical activities amount to: at least 150 min moderate intensity aerobic activity or 75 min high intensity aerobic activity per week. With one or more short daily activities the target of 30 min of physical activity per day can be reached, and additional health impacts can be achieved by more physical activity (duration, frequency, intensity), depending on one's health condition.

According to the European Health Interview Survey (EHIS) 2014-2015 data for Croatia show that 52.9% of respondents exercise less than 60 minutes, 24.3% between 60 and 150 minutes, 18% between 150 and 300 minutes and 4.7% exercise more than 300 minutes per week. In terms of daily walking, 59.6% walk less than 30 min/day, while 40.4% walk more than 30 min/day. Based on the data, more men than women walk daily for more than 30 min (44.4% of men vs. 35.8% of women). In terms of cycling/using a bicycle as a means of transportation, 60.5% use the bicycle for less than 30 min, whereas 39.5% use it for more than 30 min daily. More detailed analysis showed that

more men than women cycle daily for more than 30 min (41.4% of men vs. 37.8% of women).

Croatian data from Health Behaviour in School-aged Children – HBSC 2013/2014 study show that with age physical activity decreases with less children reported being moderate-to-vigorous physically active at least one hour daily.

The study has shown that physical activity decreases as the age increases and is lower among girls. At the age of 15, only 25% of male students and 12% of female students are physically active for 1 hour or more per day than it is recommended for their age. Nevertheless, Croatia is among 10 countries with the highest level of physical activity among students. The time spent before the TV screen has decreased since 2002 and the TV screen is replaced by a computer, cell phone or other devices.

Physical activity is of paramount importance for children and adolescents because it affects the preservation of health and prevents the development of overweight and obesity as the only known risk factor for all five leading chronic non-communicable diseases (cardiovascular, some tumours, chronic obstructive pulmonary disease, type 2 diabetes mellitus, mental illnesses). However, the sedentary lifestyle also affects the youngest and leads to an ever smaller share of this sensitive population to deal with any form of physical activity.

The proportion of students who practice moderate to intensive physical activity is decreasing with age, equally for both sexes. The proportion of male students doing moderate to intensive physical activity decreased from 39% at the age of 11 to 33% at the age of 13 and 25% at the age of 15. The proportion of female students doing moderate to intensive physical activity decreased from 26% at the age of 11 to 19% at the age of 13 and only 12% at the age of 15.

In comparison with other countries involved in HBSC research, data for Croatia suggest that although the level of physical activity among our students is low, we are more active than most. Croatian eleven-year-olds are eighth, thirteen-year-olds are in the top six, while fifteen-year-olds are tenth among all 42 countries involved in the research. In conclusion, we are 6-7% above average in all three age groups when it comes to regular physical activity. However, there is a noticeable and worrying trend of declining levels of physical activity in all countries.

The physical activity of the fifteen-year-old male students is decreasing with their age, in accordance with the general trend noted. While in 2002, 33.5% male students were physically active, that share dropped to 25.4% in 2014. Although the share of female students at the age of 15 doing physical activity regularly is twice as low as the share of their male colleagues, the decreasing trend since 2002 to date is somewhat less pronounced, dropping from 16.8% in 2002 to 11.7% in 2014. It should be noted that in comparison with 2010 there was a slight increase in the share of physically active male students, from 22% to 25.4%, or 3.4%, and for female students an increase of 3.7%, from 8% to 11.7%

In public health sector with aim of physical activity promotion community actions like campaigns, information sharing and raising awareness, education for physical activity as well as increased access to physical activity are used.

Croatian national program "Healthy living" is an example of intersectoral cooperation with components health and nutrition, health and environment, health education, health and work place and health and physical activity. Network of county public health institutes are engaged in promotion of physical activities within their regular activities, different projects and programs. They actively participate within international initiatives, marking days in health calendar, collaborating with local communities, non-governmental organizations, academic society etc.

## Conclusions

Through different tasks and activities the role of public health sector is to advocate for healthy choices to become easy choices, to work for clear understanding of all factors that are contributing to ill health and to work together with other sectors that have influence on health and physical activity. Encouraging people to become and remain physically active has numerous benefits not only for the health system but also for the economy in general. A comprehensive intersectoral approach is needed, with emphasis on environmental, social and population strategies.



## Athletes' Dual Career/ Support Young Talents

Dino Mujkić

*Faculty of Sport and Physical Education University of Sarajevo*

“Dual career” arrangements should allow Athletes to benefit from their sporting career as well to be well prepared for the time after their active sporting careers and to choose sport AND education.

Our project AtLETyC addresses this increasingly important issue that strikes elite Athletes. AtLETyC will open a new opportunity to Athletes and a new direction in their lives. They will be better educated and will even be able to create new jobs.

We want to provide educational training on Entrepreneurship at postsecondary (VET and tertiary) level with our partners to Athletes. Athletes are dedicated to achieving results and have an attitude and the capability to be the best and to succeed.

Our approach shall provide Athletes with a new career path and decrease unemployment what contributes to EU 2020 Strategy in delivering smart and inclusive growth to economy.

The Specific objectives of AtLETyC are:

- To develop a vocational and/or higher education course on Entrepreneurship Athletes which will be offered in modules
- To develop tailor-made training as the best solution.

The training will be composed of web-based modules and face to face modules according the “Blended Learning”-Concept:

- General MOOC-based modules in English on overlapping topics (e.g. Marketing, Business Plan) equal in all partner countries
- Special modules with country specific learning content (e.g. Business law, Accounting, Corporate foundations law) in form of face-to-face training in the language of the partner

Our training program can easily be tailored to the needs of others and transferred to other countries and regions in Europe, what enhances the sustainability of the project.

**“Dual career”** arrangements should allow Athletes to benefit from their sporting career as well to be well prepared for the time after their active sporting careers and to choose sport **AND** education, especially if they are forced to leave the system earlier than planned. Athletes are affected by the increasing demand of **TIME** and face the challenge to combine their sporting career with tertiary education or work.

Therefore the need for a new approach for Athletes in vocational and higher education is essential. There is also a limited access to certain career paths for Athletes because of their specific type of qualifications and experience.

Many elite athletes want to use their skills, networks and profile to start their own business during or after their sporting career. However, due to their busy schedule, they often miss out on specific education.

This is very often considered as inclusion process when you make specific programs to athletes, giving opportunity for new education. Can we think what is before and how to prevent inclusion, how to avoid exclusion in the beginning? When to start to support talents ?

## **Monitoring, interpreting, applying: a systematic field-based approach for training planning**

Antonio Dello Iacono

Orde Wingate Institute for Physical Education and Sports, Israel

**N**ot by chance, the use of technology in sport settings has experienced an exponential growth in the last 10 years contributing directly or indirectly to meaningful and positive effects on the performance improvements or addressing the athletes' health and wellbeing preservation. Through the technological application, we should be able to better understand the discipline of interest and to select and apply strategies leading to achievements.

Actually, the help and the support of the technology consist in providing valuable information that otherwise could not be available due to the obvious human capacities limitations.

In addition, this unbiased data will likely lead to efficient strategies and relevant decisions since being based on objective findings rather than personal interpretation

In this scenario, the three main actors, science, field knowledge and technology, all necessary for sport-based achievements should contribute simultaneously and sequentially. I am going to illustrate the systematic approach consisting into 5 sequential steps through which scientific knowledge, theories and evidences can be translated into field-based practical applications. In details, the following case represents a research project designed and carried out within the framework of a collaboration between the Academic College at Wingate and the Sport Science Department at Maccabi Tel Aviv football club.

Well, what the science and the scientific knowledge state about football?

The analyses of football team and individual players' movement patterns have highlighted important variables, such as the ability to perform high-

intensity running bouts and impulsive actions including accelerations, decelerations, sprints and repeated sprints, as key prerequisites for successful participation at the elite level. In addition, technical abilities such as dribbling and accurate passing of the ball over a range of distances and in different directions, have been shown to discriminate top players from their less-talented counterparts. As a consequence, in order to promote an effective transfer to the competitive environment, it is suggested that the specific football training should include technical and tactical skills in conditions similar to those that occur during match play.

However, as a common practice in the field, the main focus is addressed towards developing technical and tactical skills, while the intensity and the variability of the physiological and time-motion demands may be neglected. In fact, it commonly happens that coaches, being unaware of the work load imposed the proposed technical/tactical drills and the associated potential effects, fail in achieving the combined objectives of the training sessions.

In this context, despite it is well known that the manipulation of exercise constraints can affect the physiological responses and lead to performance improvement, limited reliable data is available with regard to football-based training drills combining specific locomotor activities with technical demands, and that include constraints applied to regular training sessions of elite football players. The availability of these reference responses could help coaches in the daily training planning by suggesting how to select task constraints which prioritize and optimize either physical performance improvement or skills mastery development.

As previously stated, the use of technology could likely help in providing the best variables which can be trusted in terms of validity, reliability and analytical relevance of real field scenarios. In this example, the computer vision technology is able to provide tracking measures of individual players, the team as a whole or subgroups of interest, the ball motion and the interactions between players and ball as well.

The findings have been extrapolated by monitoring all the official matches of an U19 team during the last season and therefore representative of this specific age group.

“In science, the purpose of any study should not be just that to measure and collect data, but to let the community thinking about making possible worthwhile changes!” With this in mind, we should design the research projects

considering that the only way to achieve a significant and valuable impact, is to provide the results and the associated findings in a way that is easy to understand by anyone – and with direct, and immediate practical applications.

Based on the findings of the official matches we have recently designed the reported study in this slide that, specifically, attempted to profile the influence of specific training constraints on the physiological and time-motion response, and technical ability outcomes of passing drills commonly used in football. In this regard, a *post-only cross-over design* was used to analyze the differences occurring due to the experimental protocols.

The experimental trials consisted of passing exercises with a triangle-shaped format of 15-m length per side, combining locomotor and technical activities, such as walking, accelerating, decelerating, sprinting and passing tasks. Specifically, the following constraints were applied:

- Structural: Either 8 or 6 players were involved
- Technical: single pass (sequences of pass-control-pass between consecutive players) or double pass (sequences of double passes between consecutive players performed only through single ball touches). The protocols were organized in intermittent bouts lasting 3 min with 1 min of passive recovery

According to the experimental design, several internal and external loads responses were collected. In addition, in order to quantify the technical performance scores, both the speed of the ball and the pass accuracy were calculated. Differences in the outcomes occurring due to the structural and the technical constraints were analyzed both quantitatively and qualitatively.

The relative distances covered during the 8-player format, both as absolute values and at high-speed, were likely greater than those of the 6-player format. Moreover, a greater amount of HAD and SD were observed as the number of players involved increased. A plausible reason for this outcome may be a “pacing effect”, which occurred due to the longer duration of recovery that took place in the 8-player protocol in comparison to the 6-player one. Therefore, the combination of running demands along fixed distances (i.e. 15 m) and lower work-to-rest time ratios in the 8-player format may have likely led the players to perform the drills quantitatively and qualitatively better, due to a greater chance to have fully recovered during the repetitive high intensity actions.

As for the technical constraints effects, different and specific profiles featured the two experimental protocols. Specifically, it is reasonable that the

sequences of double passes between consecutive players, committed them to a greater technical difficulty and dictated the pace, the tempo and the quality of the drill outcomes. Briefly, the single-pass format led to higher paces and time spent at high intensity running while the double-pass one required to perform the drill with a greater amount of acceleration and deceleration efforts.

Our data also highlighted a possibly greater effect of the 8-player and single-pass formats on the RPE responses when compared with the 6-player and double-pass ones, respectively. Recently, many authors have demonstrated the high correlation between RPE measures and high-speed running and accelerations outcomes. Our results conform to the conclusions of these authors, who showed that high-intensity running, sprint distances and accelerations are likely to be strong predictors of RPE responses in football practice.

Regarding the technical outcomes, better performances, in terms of passing speed and accuracy, were achieved during the 8-player format in comparison to the 6-player one. For this finding, it can be only speculated that a “pacing effect” has again influenced the flow of the drills leading to higher speeds and accuracies. Similar results were found when comparing the single-pass format with the double-pass one. In the latter task, the findings imply a higher difficulty for a ball carrier who firstly needs to perceive when a teammate is available and well positioned without the ball for receiving his pass. Therefore, the higher complexity of actions associated the double pass task likely led to lower scores in passing speeds and accuracy.

In conclusion, exercise monitoring and the associated detailed analysis are critical processes, since these help in understanding the workload imposed, which has practical implications for the training planning. In light of the outcomes of our study, coaches could plan passing drill formats with a variable number of players and technical demands within appropriate long-term programs addressing in a selective way specific physical and physiological adaptations or skill development.



## **ORIGINAL SCIENTIFIC PAPERS**

## Modification of pendulum test for elbow joint without additional normal used devices

Derian D. Espinosa, Luis E. Rodríguez

*Escuela Colombiana de Ingeniería Julio Garavito, Colombia*

### **Abstract**

*The spasticity is a common disorder in different disease with a big demographic impact that can be developed in any extremity, this is usually evaluated with qualitative scales, and so a new method is required to quantify the development of spasticity in any extremity. This paper proposes the use of the pendulum test as a quantitative method to measure the spasticity level in the upper limbs, only using the normal used devices to this test in the lower limbs. In this paper, we present an experimental protocol with 20 healthy subjects, to whom it were made the pendulum test for upper limbs, in the elbow joint, in three different positions; this test was done with both subject's arms. The variables obtain in the experiments were the elbow flexor-extension goniometry and the electromyography (EMG) from the biceps and triceps of the tested arm. From the data obtained could be determined different variables that can be used in clinical testing. After performing a statistical analysis, we can consider that the most symmetry position between arms, it is the position 3, that R2 was the only variable witch does not show a significant difference ( $\alpha=0.95$ ) between the three positions and also the only variable that shows a significant difference ( $\alpha=0.95$ ) between arms in the position 3; finally, we realize that study participants do not consider the position 3 as uncomfortable. These results confirm that it is possible to perform a pendulum test in the elbow joint without additional normal used devices and suggest that to perform the pendulum test for upper limbs in spastic patients, should be used the position 3 and all the got variables in these experiments, except R2.*

**Keywords:** *Electromyography; goniometry; pendulum test; spasticity.*

## 1. Introduction

Spasticity is defined for the SPASM (Support Program for Assembly of database for Spasticity Measurement) as a disorder motor coordination and sensorial control. Usually, this disease is caused by injuries in the upper neuron motor. In this disorder are evident different muscular involuntary actions in a constant and intermittent way [1], that limit the movement and produce severe pain [2], [3].

The most used clinical methods to measure progress or diminution of this disorder, it is through manual manipulation of the affected extremity for a specialist, who choose the spasticity level with the Modified Ashworth Scale (MAS) [1], [4]–[7]. How it is a manual work is inevitable the subjectivity in the results [1], [4]–[6], [8], it creates the necessity of quantitative methods to help to obtain objective results. The pendulum test is one of those methods, despite in its beginnings it was a qualitative test too, the advance in biomedical technology lets improve this [9], [10]. This test with the use of goniometry and electromyography (EMG) can give a quantitative measure of spasticity [11], it gives a simple solution for the MAS subjectivity with a reasonable cost. The pendulum test consists in raising the leg of a patient in supine position with its knee in the litter border, to a total horizontal position. The researcher asks the patient to relax as much as possible and then release the patient's leg to let it balance freely by the gravity force [9]. Regularly, the most used procedure to measure the angle of the knee by means is the goniometer (for example, one electro-goniometer used in [11] or two inertial sensors places in the thigh and the leg in [12]). On the other hand, surface electromyography (EMG) has also been used in the knee flexors and extensor muscles. The amplitudes of these signals are processed (filters and RMS) to determine a quantitative measure of spasticity.

But spasticity is a disorder that can be seen in the lower and upper extremities [9], so pendulum test in essence is not enough, because it does not consider the upper limbs. Chou and Ming proposed in [10] a device attached to a stretcher, which let perform the pendulum test in the elbow joint, it opens the possibility to use this test in the upper limbs, but with the suggestion of the use of a big device, which the specialist would have to get. The aim of this paper is to show the possibility of using the pendulum test in the upper limbs using commercial devices. In the same way it is used in the lower limb test (only electro-goniometer and electrodes for EMG). Identifying the optimal patient position, the variables to measure and its normal values.

This paper is organized in different sessions in the first part is the introduction. The next, we described the methodology used in the experiment, after we show the results obtained, the next a discussion of the results and finally some conclusions and future works about this study.

## 2. Materials and methods

It was made three different experiments to determine if it was possible to do a pendulum test in the elbow joint with only goniometry and electromyography. If this was possible, we will search for the best positions and variables with their normalized values to perform the pendulum test at the elbow joint with spastic patients, the details are shown below.

### *Participants*

This pilot study included 20 healthy volunteers with a median age of 27.1 years, distributed as follows: 50% women and 50% men. Each volunteer signed an informed consent, where was indicate the study's objective and the tests potential risks.

- Inclusion criteria: Healthy subjects who want to participate in the study.
- Exclusion criteria: Subject who exercise the before day the test day.

### *Measurements*

The experimental setup consists in a litter without protection bars and a standard chair with backrest, to make the test in the different positions. An electrogoniometer (Biometrics SG150) placed in the elbow lateral side and preamplifier electrodes (Biometrics SX230 1000) in the biceps and triceps from the tested arm and a data recollection modulus (Biometrics Datalog MWX8 Bluetooth).

The following variables were determined using Matlab software: oscillations number, swinging time (fig. 1), R1 (eq. 1), R2 (eq. 2), maximum angular velocity; all these acquired from the elbow goniogram in the sagittal plane.

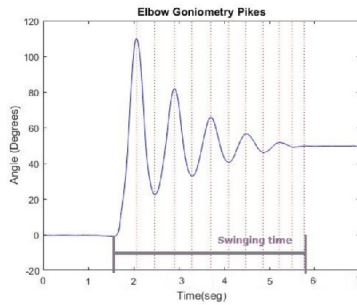

Figure 1. Swing time

The variables R1 (eq. 1) and R2 (eq. 2) were determined from the equations described for Nordmark and Aderson in [11].

$$R1 = \frac{A}{B} \quad (1)$$

$$R2 = \frac{A}{C} \quad (2)$$

The magnitudes A, B and C can be appreciated in figure 2. These variables were used in the regular pendulum test, because it was shown that the amplitude from the initial drop of the leg was most characteristic to describe the spastic level [9].

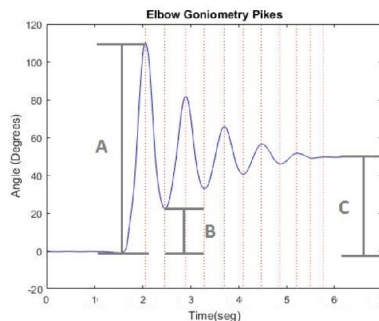
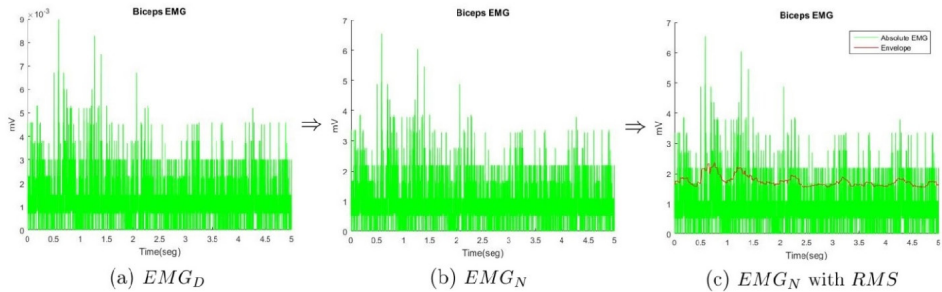

Figure 2. Magnitudes to determine R1 and R2

Also, different variables were acquired from the EMG signals normalized with the median value [13], how can be seen in the equation 3, where  $EMG_N$  is the EMG normalized (figure 3b),  $EMG_D$  is the EMG exported from the Biometrics Datalog (figure 3a),  $n$  the sample and  $N$  the samples number. The processing for the EMG signals are illustrated in the figure 3.

$$EMG_N(n) = \frac{EMG_D(n)}{\frac{1}{N} \sum_{n=0}^N EMG_D(n)} \quad (3)$$



**Figure 3. EMG treatment**

Since it is too common use the maximum voluntary contraction (MVC) values to normalize EMG signals, how this is a study projected to be used in spastic patients, the task to acquire an MVC can be difficult, that is why it was used this different method of normalizing. The variables acquired from the normalized EMG were the following: signal energy and the maximum and minimum values of the root mean square (RMS) (figure 3c).

Additionally, at the end of the data acquisition, the researcher asks the participant to order the three postures from the more comfortable to the less comfortable. In order to determine the subject's perception for each position.

### Procedure

In this article, we show three experiments in which three different positions were evaluated in both arms of volunteers to perform the pendulum test for the elbow joint, since in previous studies it was evident that the change in posture affects the results of the proof. The data acquisition was the goniometry of flexion-extension of the elbow and the EMG of the biceps and triceps of the arm under test.

With the subjects in each position, the investigator raises the patient's forearm from the arm tested and secures the shoulder to produce a horizontal arm position. The investigator asks the subject to relax as much as possible because previous studies demonstrated that the effectiveness of the pendulum test is directly related to the patient's relaxation [5]. Then the data acquisition



of the goniometer and EMG begins, finally the researcher releases the arm leaving it balanced by the gravity effect, until it reaches the rest.

The description for each position it is show below:

· Posture 1: The subject is in a prone position on a litter with the arm's shoulder from the tested arm in the litter border, it rotates this shoulder until place the elbow to the shoulders high, to let the forearm balance freely (fig. 4).



**Figure 4. Posture 1 tested**

· Posture 2: The volunteer sit in the border of a chair with backrest, with the patient back separate from backrest. The shoulder from the subject's arm which is testing, it is rotate to rest the biceps in the backrest, to let the forearm balance freely (fig. 5).



**Figure 5. Posture 2 tested**

· Posture 3: Subject is in prone position on a litter, with the tested arm out of the litter and with a shoulder rotation which put the elbow in the chest high, to let the forearm balance freely (fig. 6).



**Figure 6. Posture 3 tested**

### Statistical analysis

A descriptive statistical analysis was made from each variable separated for position, in order to have standard values from healthy subject for this test to compare with the spastic patients in future experiments. Also with the variables separated in the same way, a normality test was made and subsequently to determine if there was a significant difference between the arms for each position to determine which positions was symmetric in both arms, a comparison of means or medians according to the normality test results was made. Then the data were grouped for positions, a normality test was made for these groups, later to determine if there was a significant difference between the three positions, a comparison of means or medians according to the normality test results was made. Finally, a percentage analysis of the perception of comfort for each position was made to all the study subjects.

### 3. Results and discussion

To validate the study, from the 20 healthy participants was obtained around 300 registers; because to each position test was made three proofs for each arm, changing the postures order in an aleatory way. It had not in consideration some registers for instrumentation problems.

Initially, a descriptive statistical analysis was made from each variable separated for position, which can be seen in the *table 1*, where it is show the variable median  $\pm$  its standard deviation (its variation coefficient). From these results, it will take the standard values of healthy subjects for this pendulum test to compare with the spastic patients in future experiments.

**Table 1. Descriptive statistics from variables separated for position  $\mu \pm \sigma$  (cv)**

Variable	Position		
	1	2	3
<b>Oscillations Number</b>	5,4182 $\pm$ 0,9567 (17,6571)	4,45 $\pm$ 1,0772 (24,2063)	5,2818 $\pm$ 1,0126 (19,1714)
<b>Swing Time [s]</b>	4,7041 $\pm$ 1,0188 (21,6567)	3,927 $\pm$ 0,9526 (24,2573)	4,6472 $\pm$ 0,9483 (20,4054)
<b>R1 [degrees]</b>	4,4865 $\pm$ 2,5644 (57,1569)	2,8198 $\pm$ 0,7346 (26,0524)	2,8198 $\pm$ 0,7346 (26,0524)
<b>R2 [degrees]</b>	1,9798 $\pm$ 0,2679 (13,5291)	1,6807 $\pm$ 0,2734 (16,2647)	1,6807 $\pm$ 0,2734 (16,2647)
<b>Maximum angular velocity [degrees/s]</b>	678,1818 $\pm$ 1,5756e+03 (232,3329)	404,5455 $\pm$ 65,5063 (16,1926)	430.9091 $\pm$ 77,5135 (17,9884)

<b>Median Biceps EMG</b>	0,1964±1,1664 (593,8309)	0,0064±0,0059 (92,6675)	0,0026±0,0022 (83,6688)
<b>Median Triceps EMG</b>	0,0864±0,4961 (573,8958)	0,0061±0,0035 (56,8447)	0,0032±0,0024 (75,9046)
<b>Signal Energy of Biceps EMG</b>	1.8667e+04±1,3713e+04 (73,4652)	1,4209e+04±7,1504e+03 (50,3232)	2,5098e+04±2,966e+04 (118,1916)
<b>Signal Energy of Triceps EMG</b>	1,6329e+04±6,0381e+03 (36,9776)	1,2946e+04±3,8973e+03 (30,1049)	1,77e+04±8,5117e+03 (48,0894)
<b>Maximum value of Biceps EMG</b>	5,5227e+03±3,6346 (65,8124)	4,7236±2,774 (58,736)	7,3166±5,8628 (80,1295)
<b>Minimum value of Biceps EMG</b>	1,5309±0,0376 (2,4564)	1,5406±0,0395 (2,565)	1,5201±0,0397 (2,6118)
<b>Maximum value of Triceps EMG</b>	4,5134±1,985 (43,9798)	3,8385±1,2019 (31,3107)	5,0767±2,2569 (44,4553)
<b>Minimum value of Triceps EMG</b>	1,5325±0,0581 (3,7903)	1,5456±0,0433 (2,7987)	1.5202±0,0428 (2,8136)

Later, a Kolmogorov Smirnov normality test was made for the variables separated for position, because the amount of registers was more than 30, subsequently to determine if there was a significant difference between the arms, it was made a Wilcoxon median difference test with a reliability level of 95%, because the both groups (right and left arm) were related and any of the variables had a normal distribution. The results show that the position most symmetry between arms was the position 3, in all the tested variables except for R2. These results can be seen in the *table 2*, where 1 means that there was a significant difference and 0 the opposite.

**Table 2. Wilcoxon test results to compare variables between arms in each position**

Variable	Position		
	1	2	3
<b>Oscillations Number</b>	1	0	0
<b>Swing Time [s]</b>	1	0	0
<b>R1 [degrees]</b>	0	0	0
<b>R2 [degrees]</b>	0	0	1
<b>Maximum angular velocity [degrees/s]</b>	0	0	0
<b>Median Biceps EMG</b>	1	0	0
<b>Median Triceps EMG</b>	1	1	0
<b>Signal Energy of Biceps EMG</b>	1	0	0
<b>Signal Energy of Triceps EMG</b>	0	0	0
<b>Maximum value of Biceps EMG</b>	1	0	0
<b>Minimum value of Biceps EMG</b>	1	0	0
<b>Maximum value of Triceps EMG</b>	0	0	0
<b>Minimum value of Triceps EMG</b>	1	1	0

Then the variables were grouped for positions, the respective Kolmogorov Smirnov normality test was made and then a Friedman median difference test ( $\alpha=0.95$ ) comparing the three groups (position 1, 2 and 3), because any variable had a normal distribution. The Friedman test results show that the only variable which does not differ between positions is R2, this can be seen in the *table 3*, where 1 means that there was a significant difference and 0 the opposite.

**Table 3. Friedman test results of compare variables between positions**

Variable	Result
Oscillations Number	1
Swing Time [s]	1
R1 [degrees]	1
R2 [degrees]	0
Maximum angular velocity [degrees/s]	1
Median Biceps EMG	1
Median Triceps EMG	1
Signal Energy of Biceps EMG	1
Signal Energy of Triceps EMG	1
Maximum value of Biceps EMG	1
Minimum value of Biceps EMG	1
Maximum value of Triceps EMG	1
Minimum value of Triceps EMG	1

Finally, with the information on the poll about the comfort in each position perceived for the subjects, a percentage analysis was made. This can be appreciated in the graphic of figure 7, where the horizontal axis represented the percentage of our volunteer population, the colors represented the three positions tested (gray the position 1, orange the position 2 and blue the position 3) and in the vertical axis are the three different comfort perceptions (uncomfortable, moderately comfortable, the most comfortable). In these results, it can be seen that the position 3 was not perceived as uncomfortable and that the most common perception was the position 2 as uncomfortable.

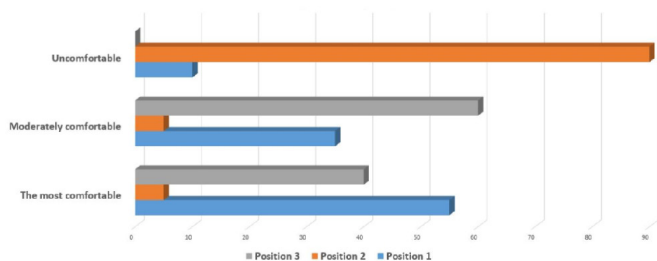

**Figure 7. Percentage of comfort perception**

With these results, it is evident that it is possible to do the pendulum test in the elbow joint without additional normal used devices in contrast with the big device used for this exam in [10]. Now to determine which of the three positions and which variables would be the best option to realize the studies with spastic patients. It was searched in the statistical study, the position with symmetry in both arms and perceived as comfortable; also it was searching the variables symmetric for both arms and with independence between positions. So, to realize the pendulum test with spastic patients in the elbow joint without additional instruments, we propose to use the position 3, because it is the most symmetry and it is not perceived as uncomfortable. And also it should be used all the variables measured in this paper without R2, because it is the only asymmetry variable in the position 3 and also the only variable which does not differ between positions. This show that exist a transcendental difference between the pendulum test for knee and elbow proposed in this study, because R2 is a descriptive variable of the pendulum test in knee joint, as can be seen in [6], [9], [11].

The normal values that it will be considered for the spastic patients next studies, will be the variables  $\mu \pm \sigma$  from the registers of position 3 (table 1, column 3). In the other hand, if it is taken a closer look of the descriptive statistics of this position, it can project that in many variables will be a significant difference between healthy patients and the spastic ones, because the variables in the position 3 had a low variation coefficient.

#### 4. Conclusions

With the pertinent work with common biomedical sensors usually used to perform the conventional pendulum test (for the knee joint), it is possible to make this test in the elbow joint as can be seen in the three experiments showed in this paper. In addition, to realize this test in spastic patients, the more advisable it is to use the position 3 because it is symmetry and also because it is not perceived as uncomfortable. Besides should be calculated all mentioned variables without R2 for its asymmetry in the position 3 and its symmetry between positions. The variables with lower variation coefficient will be prioritized in spastic patient's experiments.

It is probable that the results of the pendulum test for elbow joint in spastic patients will show that exist variables with significant differences between healthy and spastic patients, also that the variables' threshold for

healthy patients will have a small confidence interval, because the variables in the position 3 have a low variation coefficient.

## 5. References

[1] J. Fleuren, Assessment of spasticity from EMG to patients' perception, Gildeprint Drukkerijen, Enschede, **(2009)**.

[2] Q. Peng, P. Shah, R. W. Selles, D. J. Gaebler-Spira, and L-Q. Zhang, "Measurement of ankle spasticity in children with cerebral palsy using a manual spasticity evaluator," Conf. Proc. ... Annu. Int. Conf. IEEE Eng. Med. Biol. Soc. IEEE Eng. Med. Biol. Soc. Annu. Conf., vol. 7, pp. 4896–9, San Francisco, USA, **(2004)**.

[3] Y. N. Wu, H. S. Park, Y. Ren, D. Gaebler-Spira, J. J. Chen, and L. Q. Zhang, "Measurement of elbow spasticity in stroke patients using a manual spasticity evaluator," Annu. Int. Conf. IEEE Eng. Med. Biol. - Proc., pp. 3974–3977, New York City, USA, **(2006)**.

[4] R. H. Bhimani, C. Peden-McAlpine, J. Gaugler, and L. C. Anderson, "Spasticity over time during acute rehabilitation: A study of patient and clinician scores," Appl. Nurs. Res., vol. 30, pp. 16–23, **(2016)**.

[5] K. S. Kim, J. H. Seo, and C. G. Song, "Portable measurement system for the objective evaluation of the spasticity of hemiplegic patients based on the tonic stretch reflex threshold," Med. Eng. Phys., vol. 33, no. 1, pp. 62–69, **(2011)**.

[6] C. H. Yeh et al., "Novel application of a Wii remote to measure spasticity with the pendulum test: Proof of concept," Gait Posture, vol. 43, pp. 70–75, **(2016)**.

[7] J. F. M. Fleuren et al., "Stop using the Ashworth Scale for the assessment of spasticity To cite this version :," HAL Arch., **(2011)**.

[8] J. Kim, H. S. Park, and D. L. Damiano, "Accuracy and reliability of haptic spasticity assessment using HESS (Haptic Elbow Spasticity Simulator)," Proc. Annu. Int. Conf. IEEE Eng. Med. Biol. Soc. EMBS, pp. 8527–8530, Boston, USA, **(2011)**.

[9] T. Bajd and L. Vodovnik, "Pendulum testing of spasticity," J. Biomed. Eng., vol. 6, no. 1, pp. 9–16, **(1984)**.

[10] C. C. Lin, M. S. Ju, and C. W. Lin, "The pendulum test for evaluating spasticity of the elbow joint," Arch. Phys. Med. Rehabil., vol. 84, no. 1, pp. 69–74, **(2003)**.

[11] E. Nordmark and G. Anderson, "Wartenberg pendulum test: objective quantification of muscle tone in children with spastic diplegia undergoing selective dorsal rhizotomy," *Dev. Med. Child Neurol.*, vol. 44, no. 1, pp. 26–33, **(2002)**.

[12] L. Bar-On et al., "A clinical measurement to quantify spasticity in children with cerebral palsy by integration of multidimensional signals," *Gait Posture*, vol. 38, no. 1, pp. 141–147, **(2013)**.

[13] J. N. and A. M. Javier Rodriguez-Falces, *Computational Intelligence in Electromyography Analysis - A Perspective on Current Applications and Future Challenges*. **(2012)**.

### Authors Info

Luis E. Rodríguez, PhD: [luis.rodriquez@escuelaing.edu.co](mailto:luis.rodriquez@escuelaing.edu.co)

Eng. Derian D. Espinosa (Master student): [derian.espinosa@escuelaing.edu.co](mailto:derian.espinosa@escuelaing.edu.co)

# Exercise in pregnancy and the postpartum period: perceptions, practices and recommendations

Slavica Žeger

American University of the Middle East, Kuwait

## Abstract

*Physical activity is associated with decreased mortality and it is known to improve general quality of life. Positive effects of physical activity extend to pregnancy as well as the postpartum period. Pregnancy is associated with profound physiologic and anatomic changes and is often considered as a state of confinement. Contrary to conservative opinions, exercise in pregnancy is now considered as an ideal time for continuing healthy lifestyle established prior pregnancy, as well as initiating one while pregnant. An exercise program for postnatal women can produce many benefits that far outreach just physical conditioning. This paper summarizes knowledge on exercise impact on health of the expectant mother and the fetus, extending its reach to current practices and perceptions toward exercise in pregnancy and the postpartum period.*

**Keywords:** pregnancy, postpartum period, physical activity, exercise

## 1. Introduction

It is well-known that physical activity (PA) results in substantial health benefits reducing the risk of obesity and improving the components of physical fitness in all stages of life. Although exercise regimen has become an important part of everyday life for many women, it was not always the case. Historically, expectant mothers were advised not to take part in PA out of fear of miscarriage, premature delivery, musculoskeletal injuries, and other concerns associated with fetal risk. Today, hypokinesia and excessive weight gain have been recognized as risk factors for maternal obesity and related pregnancy complications, including gestational diabetes mellitus. Due to misguided



recommendations, expectant mothers were advised to increase their calorie intake and move less which led to excessive weight gain becoming prevalent among all weight categories [1] with extension to the weight retention after pregnancy. Moreover, recent study found a causal relationship between maternal obesity and higher birth weight of the offspring [2] thus actually contributing to intergenerational obesity transmission. Before 1980s, little research on this topic has been conducted, mostly on animals, with often inconclusive or contradictory results. Since then, the number and scope of studies on maternal exercise has increased, leading to interesting findings on how exercise positively affects both, the mother and the fetus. It was not until 1985, that the first guidelines for exercise during pregnancy and the postpartum period were published by the American Congress of Obstetricians and Gynecologists (ACOG), with the latest guidelines being published in 2015. As per aforementioned ACOG's report, pregnancy is an ideal time not just for maintaining, but as well as for adopting a healthy lifestyle. Despite the guidelines, just a small portion of pregnant and postpartum women carry out the necessary amount of exercise. The majority of reported reasons for that refer to safety concerns or lack of knowledge on amount, type, intensity, or frequency of exercise that can be performed during pregnancy and in the postpartum period. A substantial body of literature has shown that regular, moderate-level exercise during pregnancy has benefits including reduced fat deposition and retention, shorter and less complicated labors, and a more rapid recovery postpartum [3][4][5]. Contrary to early concerns on exercise in pregnancy, recent studies confirmed there are no adverse long or short-term effects on health of the mother or fetus in uncomplicated pregnancies [6][7]. In the absence of medical complications, exercise during pregnancy is considered safe and desirable, and expectant mothers should be encouraged to take part in it because beneficial effects of exercise far outweigh the risks [8]. Indeed, risks of not taking part in exercise during pregnancy are significant and include the loss of cardiovascular and muscular fitness, excessive weight gain (with retention especially in the central rather than peripheral body area), possible development of varicose veins and deep vein thrombosis, lower back pain, poorer psychological adjustment to mechanical and physiological changes in pregnancy, etc. [9]. This paper summarizes effects and recommendations for PA during pregnancy as well as current practices and perceptions towards exercise in pregnancy and the postpartum period.

## 2. Exercise effects on health of the expectant mother and the fetus

Pregnancy is associated with major anatomical and physiological changes. Mechanical changes result in a shift in the point of gravity which leads to progressive lordosis and problems with balance. More than 60% of women experience lower back pain during pregnancy [10], as well as greater discomfort when it comes to exercise in later stages of pregnancy. Joint laxity occurs due to hormonal changes in pregnancy in order to facilitate delivery, but there is no documented evidence of increased injury rate of pregnant women due to joint laxity. Changes in pulmonary system are also associated with pregnancy, increasing minute ventilation up to 50% due to increased tidal volume. During rest, respiratory frequency of non-pregnant and pregnant women is found to be the same. Heat production is increased due to fetoplacental metabolism keeping the fetal temperature 0.5-1°C above maternal. When exercise and pregnancy are combined, a slight increase in temperature is expected but does not exceed into the range of concern. Some studies have found relative risk of defects from heat exposure in hot tubs and saunas, associated with greater risk of neural tube defects [11]. Also, some theoretic concerns in pregnancy refer to an increased heart rate (HR) and cardiac output [12] although blood is diverted from the abdominal area to supply exercising muscles. Studies on fetal hypoxia to date showed very inconclusive results [13].

**Figure 1.** Effect of moderate maternal exercise and fetal adaptations in a low-risk pregnancy

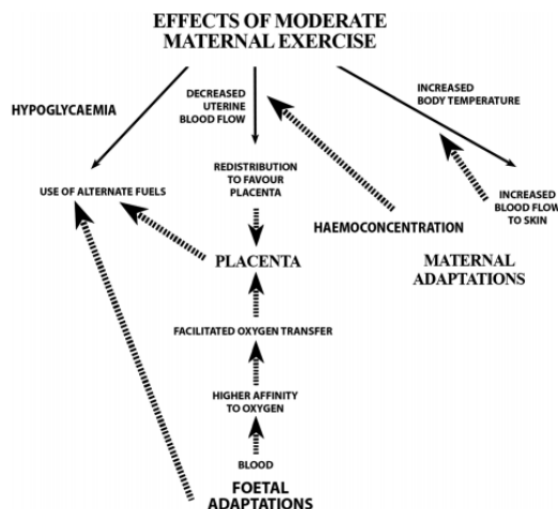

Source: Bø et al., 2016 [14]

Maternal supine body position can affect cardiac output during pregnancy and according to guidelines should be avoided. This also applies to certain yoga positions and also have implications on women who work throughout pregnancy [15]. Caloric demand enhances in pregnancy, especially when combined with exercise. Increased intake of 150 calories/day is recommended in the first and second trimester and an increase of 300 calories/day in the third trimester. However, the popular cultural belief of “eating for two” during pregnancy is oftentimes contributes to caloric intake above normal levels, leading to an excessive weight gain and postpartum retention [16]. Weight gain between 11 and 16 kg is considered to be sufficient to enable fetal development and growth [17]. Values above that are considered to be unnecessary. Some studies have found an increase in fetal HR by 10-30 BPM during or after exercise, but maternal exercise in general seems to be well tolerated in uncomplicated pregnancies, if not performed in supine position, as mentioned [18]. The study by Watson [19] detected fetal bradycardia in approximately 15% of cases in untrained women when performing near maximal capacity, and in activities like cycling it occurs more often than in swimming. However, a maximum level of exercise well tolerated by fetus has still not been established. When it comes to effects of exercise on birth weight, multiple studies shown minimum differences in weighted mean birth weight for infants whose mothers exercised during pregnancy when compared with controls [20].

### **3. Exercise in the postpartum period**

Postpartum care includes (1) hospital care, (2) immediate postpartum period; 2 weeks after delivery and (3) postpartum period of up to 6 weeks after delivery [21]. Extensive changes on physical and mental plan that women face after childbirth resulted in reconsidering the duration of the postpartum period by some experts, from arbitrary defined six weeks to one year. During postpartum, exercise is rarely part of the plan, as postpartum is usually a period dedicated to factors such as breast feeding and infant care, leaving relatively little attention to exercise during this time. Guidelines have been established for safe exercise in pregnancy which unfortunately is not the case with the postpartum period. Lack of specific guidelines on postpartum exercise does not necessarily mean that women are not interested in exercising. Study by Moran [22] explored this topics of interest of women after childbirth where 78% of them reported to be interested in more information on diet, nutrition, and exercise.

A healthy lifestyle that includes exercise plays an important role in postpartum, facilitating weight loss [23] and decreasing depression and anxiety.

Alongside with benefits, theoretic concerns on compatibility of exercise and lactation as well as concerns over vaginal bleeding, *distasis recti* (DRA) and urinary stress incontinence occur. Vaginal bleeding starts right after delivery, but there is no solid evidence that it is further increased due to exercise. Both exercise and lactation are highly energy demanding processes, but according to Cary&Quinn [24], moderate intensity exercise will not lead to accumulation of lactic acid in breast milk. Therefore, exercise is considered safe during lactation. It would seem that the exception to that rule might be maximal aerobic load where some studies questioned the immune properties of milk among exercising women who are nursing. However, some studies showed that IgA levels were back to pre-exercise values within one hour after taking part in exercise [25]. Etiology of DRA is still not clear, but it may occur in more than half of all pregnancies. Study on effects of and exercise program on DRA in pregnant women concluded that the occurrence and size of DRA is much greater in non-exercising woman than in exercising pregnant women [26] although prevalence studies on DRA in elite athletes do not exist. Systematic reviews on effects of exercise on DRA [27] suggest more research on this topic as there are few high-quality studies on the subject making it hard to prevent and treat. It is also important to start the Kegel exercise routine in the immediate postpartum period (as soon as 12 hours later), as it was found to be beneficial in reducing the risk of urinary incontinence [28]. Exercise prescription slightly differs for women who had a vaginal delivery compared to women who had a caesarian section as latter need some extra care and support (scar mobilization and core strengthening). Exercise participation is also known for improving postpartum depression (PPD)[29], and can be a good source of social support. Role of a kinesiologist in the postpartum period is to establish realistic expectations on exercise goals as the postpartum body takes time (between six months and one year) to fully recover from effects of pregnancy.

#### **4. Perception, practices and recommendations**

Studies have shown that adverse pregnancy and neonatal outcomes do not increase in women who take part in PA. Generally, pregnant woman think that engaging in moderate exercise during pregnancy is safe. Nevertheless, they are less certain about vigorous activities [30] leading to a decrease of its practice. Although most expectant mothers understand the benefits of PA in pregnancy, that does not seem to translate to an increasing practice. Research showed that a great share of women is fully aware of benefits of PA in pregnancy and postpartum but are not actually being willing to incorporate it. Study

on PA barriers, beliefs and enablers among 530 postpartum women showed that they believe PA is appropriate at three months postpartum. Identified were also most common barriers to PA; lack of time and issues with child care [31]. According to Hegaard et al. [32], barriers can be overcome by using role models, mirroring activities of other pregnant women and following advice of experts (care providers, kinesiologists, nurses). Problems occur when care providers impose conflicting information on pregnant women. In the absence of precise and relevant information, women will turn to look for information on the Web, in books, or friends to guide their PA behaviors during pregnancy [33]. Even a health professional can sometimes impose conflicting or inconsistent information on women, presumably based on their personal beliefs.

There is a difference between perceived and actual time for postpartum recovery, and every pregnancy should be assessed individually. Kegel exercise is considered to be safe throughout pregnancy. Pregnancy exercise design should be based on the anatomical and physiological changes that occur during pregnancy, and the intensity, duration, frequency, and mode of exercise should be adapted accordingly. Some researchers suggest a training HR to be a poor measure of exertion, due to hormonal changes affecting HR response wherefore Borg RPE scale (minimum score 6 to a maximum of 20) is considered to be an appropriate tool to keep women from reaching a high-intensity threshold.

PREGNANCY	POSTPARTUM
<p>Jogging, stationary bike Low impact aerobics Combination of low impact aerobics and strength exercises Kegel exercises</p>	<p>Kegel exercises – immediate postpartum period Brisk walking Incorporating baby in exercise routine (jogging strollers e.g.) “Sahrman exercises” After cesarean section - incorporate exercise after 4 to 8 weeks (scar mobilization and core strengthening)</p>
<p>Long distance running, gymnastics, water skiing, skating Vigorous racquet sports (e.g. squash) Contact sports (martial arts, hockey, ice hockey, football) Isometric exercises, weight lifting, supine position exercises Scuba diving, skydiving Exertion at altitudes higher than 6000 feet Activities that require balance and extreme range of motion should be avoided in late pregnancy Bobsledding, luge, equestrian activities, pole vaulting, downhill ski racing</p>	<p>Traditional abdominal exercises in case of DRA Strength training before scars are healed and vaginal bleeding has stopped Vigorous cardio exercises in first 4 weeks</p>

**Table 1.** Recommended activities (marked in green) and activities to discourage (marked in red) during pregnancy and postpartum period for general population

Recommended activities during pregnancy and postpartum are shown in Table 1. One should avoid activities of high risk such as contact sports, martial arts, activities that produce high risk of losing balance and fetal trauma such as scuba diving, skydiving and waterskiing. In contrary to popular myths, core exercises are safe, moreover they can produce many benefits as they are maintaining abdominal strength and function. In addition to core exercises, Kegel exercise are highly advisable as poor pelvic floor strength is associated with many problems including urinary incontinence, low back and pelvic pain etc. Exercise should be an integral part of postpartum care, encouraged first by nurses because they are the ones taking care of woman in the first postpartum days, in cooperation with an obstetric provider. No opportunities should be missed on supporting and educating women at that time on importance of controlled physical exercise in order to increase their chances to pursuit PA postpartum. Interventions based on these findings are needed in order to increase awareness and social support to help women be physically active postpartum.

### ***The Pregnant Athlete***

Key point for a pregnant athlete is to establish whether being involved in sport puts the fetus at risk. Stated depends on several factors some of which are the training schedule and the load, combative or noncombative activity, competition environment, etc. Based on the specific environment of the individual athlete, a decision should be made with bearing in mind maternal and fetus health and their safety as the priority. It is highly advisable to seek a logistic help of a specialized performance lab that is sufficiently equipped to monitor maternal and fetal health to make sure wellbeing is not compromised by the training load. Nutritional requirements for a normal pregnancy increase, but for pregnant athletes they are even higher. According to a study on energy requirements during pregnancy and lactation [34], women with a mean gestational weight gain of 12kg should consume additional 90 kcal/day for the first trimester, 287 kcal/day for the second trimester and 466 kcal/day for the third trimester of pregnancy. Due to high energy expenditure in sport, pregnant athletes need to make sure they adhere to healthy weight gain requirements, especially because there is evidence that the frequency of eating disorders is higher among athletes (20–22%) than non-athletes (3–9%) [35]. Competitive athletes are experiencing the same anatomical changes as general population, but special attention should be given to the alteration in

body biomechanics, as it changes the required form needed in a specific sport. Postural changes combined with a shift in center of gravity to allow space for the expansion of the uterus can cause a tendency for the body to pitch forward which can represent a potential source of sport injury [36]. Moreover, pregnant athletes are also inclined to changes in blood glucose during and after exercise. To prevent a possible hypoglycemic reaction, it is advisable to have a quick access to a carbohydrate snack. Greater risk for hyperthermia and dehydration also exist in this population, especially during intense exercise. Although, some theoretic questions on premature labor among pregnant athlete arise, there is no significant evidence on that to date [37]. A study on effects of pregnancy on the army physical fitness test (AFFT) is suggesting that complications, weight gain, and postpartum exercise practices have significant effect on AFFT scores [38]. Moreover, the study revealed that the current pregnancy profile of six months is not enough time to recover from all the changes accompanied by the pregnancy and to perform back on top before-pregnancy levels. A question arises; if this paradigm refers to female professional soldiers who have had high levels of fitness even before pregnancy, where do average physically active women stand, not to mention those who were not even sufficiently active before pregnancy? If six months is not enough time for professional soldiers to perform at before-pregnancy level, it is highly questionable whether one year postpartum period is enough for an average physically active woman to resume her before-pregnancy physique.

## 5. Conclusions

Recent studies on exercise regimen in pregnancy showed no increase in miscarriages, complications in the third trimester, abnormal fetal growth, or adverse neonatal outcomes, suggesting that previous recommendations on exercise in pregnancy may have been too conservative [37][39]. Exercise during the postpartum period has many benefits for both the mother and the infant. Benefits are indeed numerous; from psychological and physiological and all the way up to a better mother-baby bond due to incorporating baby into the postpartum exercise routine. Every woman without contraindications should be encouraged to have a healthy lifestyle which includes a balanced mix of healthy diet, aerobic, and strength and conditioning exercise. A reasonable level of exercise is recommended, excluding vigorous (close to maximum) or any type of physical preparations for competitions for the general population.



Great number of elite female athletes are competing on professional level in their 30s, and it is expected that at some point they might want to become mothers. Thirties are also the time of peak performance which is why good cooperation between expectant mothers-athletes and their care providers should be established even before conception and maintained afterwards to build trust as well as to closely monitor the fetus wellbeing.

Health care providers first, followed by exercise professionals should play a more active role in educating women on benefits of PA in pregnancy as well as on limitations and dangers that are connected with pregnancy and postpartum. The present health education system may be failing to educate women, leaving space for myths and misguided perceptions on exercise in pregnancy and postpartum to take place consequently leading to lower levels of maternal PA.

## 6. References

1. Institute of Medicine (US) and National Research Council (US) Committee to Reexamine IOM Pregnancy Weight Guidelines. Weight Gain During Pregnancy: Reexamining the Guidelines [Internet]. Rasmussen KM, Yaktine AL, editors. Washington (DC): National Academies Press (US); 2009 [cited 2017 Apr 18]. (The National Academies Collection: Reports funded by National Institutes of Health). Available from: <http://www.ncbi.nlm.nih.gov/books/NBK32813/>
2. Tyrrell J, Richmond RC, Palmer TM, Feenstra B, Rangarajan J, Metrustry S, Cavadino A, Paternoster L, Armstrong LL, Silva NMGD, Wood AR, Horikoshi M, Geller F, Myhre R, Bradfield JP, Kreiner-Møller E, Huikari V, Painter JN, Hottenga J-J, Allard C, Berry DJ, Bouchard L, Das S, Evans DM, Hakonarson H, Hayes MG, Heikkinen J, Hofman A, Knight B, Lind PA, McCarthy MI, McMahon G, Medland SE, Melbye M, Morris AP, Nodzenski M, Reichetzeder C, Ring SM, Sebert S, Sengpiel V, Sørensen TIA, Willemsen G, Geus EJC de, Martin NG, Spector TD, Power C, Järvelin M-R, Bisgaard H, Grant SFA, Nohr EA, Jaddoe VW, Jacobsson B, Murray JC, Hoher B, Hattersley AT, Scholtens DM, Smith GD, Hivert M-F, Felix JF, Hyppönen E, Lowe WL, Frayling TM, Lawlor DA, Freathy RM. Genetic Evidence for Causal Relationships Between Maternal Obesity-Related Traits and Birth Weight. *JAMA*. 2016 Mar 15;315(11):1129–40.
3. Clapp III JF, Kim H, Burciu B, Schmidt S, Petry K, Lopez B. Continuing regular exercise during pregnancy: Effect of exercise volume on fetoplacental growth. *American Journal of Obstetrics and Gynecology*. 2002 Jan;186(1):142–7.
4. Wang TW, Apgar BS. Exercise during pregnancy. *American Family Physician*. 1998;57:1846–1859.



5. Sampsel CM, Seng J, Yeo S, Killion C, Oakley D. Physical Activity and Postpartum Well-Being. *Journal of Obstetric, Gynecologic & Neonatal Nursing*. 1999 Jan 1;28(1):41–9.
6. Tinloy J, Chuang CH, Zhu J, Pauli J, Kraschnewski JL, Kjerulff KH. Exercise during pregnancy and risk of late preterm birth, cesarean delivery, and hospitalizations. *Womens Health Issues*. 2014;24(1):e99–104.
7. Barakat R, Perales M, Bacchi M, Coteron J, Refoyo I. A program of exercise throughout pregnancy. Is it safe to mother and newborn? *Am J Health Promot*. 2014 Oct;29(1):2–8.
8. Ewing G Carol, Blissmer, Bryan, Deschenes, Michael R., Franklin, Barry A., Lamonte, Michael J., Lee, I-Min, Nieman, David C., Swain, David P. Quantity and Quality of Exercise for Developing and Maintaining Cardiorespiratory, Musculoskeletal, and Neuromotor Fitness in Apparently Healthy Adults: Guidance for Prescribing Exercise [Internet]. LWW. [cited 2017 Apr 18]. Available from: [http://journals.lww.com/acsm-msse/Fulltext/2011/07000/Quantity\\_and\\_Quality\\_of\\_Exercise\\_for\\_Developing.26.aspx](http://journals.lww.com/acsm-msse/Fulltext/2011/07000/Quantity_and_Quality_of_Exercise_for_Developing.26.aspx)
9. Wolfe LA, Davies GAL. Canadian Guidelines for Exercise in Pregnancy: Clinical Obstetrics and Gynecology. 2003 Jun;46(2):488–95.
10. Wang S-M, Dezinno P, Maranets I, Berman MR, Caldwell-Andrews AA, Kain ZN. Low back pain during pregnancy: prevalence, risk factors, and outcomes. *Obstet Gynecol*. 2004 Jul;104(1):65–70.
11. Milunsky A, Ulcickas M, Rothman KJ, Willett W, Jick SS, Jick H. Maternal heat exposure and neural tube defects. *JAMA*. 1992 Aug 19;268(7):882–5.
12. Pivarnik JM, Lee W, Clark SL, Cotton DB, Spillman HT, Miller JF. Cardiac output responses of primigravid women during exercise determined by the direct Fick technique. *Obstetrics And Gynecology*. 1990 Jun;75(6):954–9.
13. Szymanski LM, Satin AJ. Exercise During Pregnancy: Fetal Responses to Current Public Health Guidelines. *Obstet Gynecol*. 2012 Mar;119(3):603–10.
14. Bø K, Artal R, Barakat R, Brown W, Davies GAL, Dooley M, Evenson KR, Haakstad LAH, Henriksson-Larsen K, Kayser B, Kinnunen TI, Mottola MF, Nygaard I, van Poppel M, Stuge B, Khan KM. Exercise and pregnancy in recreational and elite athletes: 2016 evidence summary from the IOC expert group meeting, Lausanne. Part 1-exercise in women planning pregnancy and those who are pregnant. *Br J Sports Med*. 2016 May;50(10):571–89.
15. Clark SL, Cotton DB, Pivarnik JM, Lee W, Hankins GDV, Benedetti TJ, Phelan JP. Position change and central hemodynamic profile during normal third-trimester pregnancy and post partum. *American Journal of Obstetrics and Gynecology*. 1991 Mar 1;164(3):883–7.

16. Clark M, Ogden J. The impact of pregnancy on eating behaviour and aspects of weight concern. *Int J Obes Relat Metab Disord*. 1999 Jan;23(1):18–24.
17. Thorsdottir I, Torfadottir JE, Birgisdottir BE, Geirsson RT. Weight gain in women of normal weight before pregnancy: complications in pregnancy or delivery and birth outcome. *Obstetrics & Gynecology*. 2002 May;99(5, Part 1):799–806.
18. Monga M. Fetal Heart Rate Response to Maternal Exercise. *Clinical Obstetrics and Gynecology* [Internet]. 2016 Sep [cited 2017 Apr 18];59(3). Available from: [http://journals.lww.com/clinicalobgyn/Fulltext/2016/09000/Fetal\\_Heart\\_Rate\\_Response\\_to\\_Maternal\\_Exercise.16.aspx](http://journals.lww.com/clinicalobgyn/Fulltext/2016/09000/Fetal_Heart_Rate_Response_to_Maternal_Exercise.16.aspx)
19. Watson WJ, Katz VL, Hackney AC, Gall MM, McMurray RG. Fetal responses to maximal swimming and cycling exercise during pregnancy. *Obstet Gynecol*. 1991 Mar;77(3):382–6.
20. Leet T, Flick L. Effect of Exercise on Birthweight. *Clinical Obstetrics and Gynecology* [Internet]. 2003 Jun [cited 2017 Apr 19];46(2). Available from: [http://journals.lww.com/clinicalobgyn/Citation/2003/06000/Effect\\_of\\_Exercise\\_on\\_Birthweight.21.aspx](http://journals.lww.com/clinicalobgyn/Citation/2003/06000/Effect_of_Exercise_on_Birthweight.21.aspx)
21. Stover AM, Marnejon JG. Postpartum care. *American Family Physician*. 1995 Oct;52(5):1465–72.
22. Moran CF, Holt VL, Martin DP. What do women want to know after childbirth? *Birth*. 1997 Mar;24(1):27–34.
23. Rössner S, Ohlin A. Pregnancy as a risk factor for obesity: lessons from the Stockholm Pregnancy and Weight Development Study. *Obes Res*. 1995 Sep;3 Suppl 2:267s–275s.
24. Cary GB, Quinn TJ. Exercise and lactation: are they compatible? *Can J Appl Physiol*. 2001 Feb;26(1):55–75.
25. Carey GB, Quinn TJ. Effect of exercise on milk and nursing babies. *Med Sci Sports Exerc*. 1998 Nov;30(11):1659–60.
26. Chiarello C, Falzone LA, McCaslin KE, Patel MN, Ulery KR. The Effects of an Exercise Program on Diastasis Recti Abdominis in Pregnant Women. *Journal of Women's Health Physical Therapy*. 2005 Spring;29(1):11–6.
27. Benjamin DR, van de Water ATM, Peiris CL. Effects of exercise on diastasis of the rectus abdominis muscle in the antenatal and postnatal periods: a systematic review. *Physiotherapy*. 2014 Mar;100(1):1–8.
28. Mørkved S, Bø K. Effect of postpartum pelvic floor muscle training in prevention and treatment of urinary incontinence: a one-year follow up. *BJOG: An International Journal of Obstetrics & Gynaecology*. 2000 Aug 1;107(8):1022–8.

29. Daley AJ, Psychol C, MacArthur C, Winter H. The Role of Exercise in Treating Postpartum Depression: A Review of the Literature. *The Journal of Midwifery & Women's Health*. 2007 Jan 2;52(1):56–62.
30. Mudd LM, Nechuta S, Pivarnik JM, Paneth N. Factors associated with women's perceptions of physical activity safety during pregnancy. *Preventive Medicine*. 2009 Aug;49(2–3):194–9.
31. Evenson KR, Aytur SA, Borodulin K. Physical Activity Beliefs, Barriers, and Enablers among Postpartum Women. *J Womens Health (Larchmt)*. 2009 Dec;18(12):1925–34.
32. Hegaard HK, Kjaergaard H, Damm PP, Petersson K, Dykes A-K. Experiences of physical activity during pregnancy in Danish nulliparous women with a physically active life before pregnancy. A qualitative study. *BMC Pregnancy and Childbirth*. 2010;10:33.
33. Cioffi J, Schmied V, Dahlen H, Mills A, Thornton C, Duff M, Cummings J, Kolt GS. Physical Activity in Pregnancy: Women's Perceptions, Practices, and Influencing Factors. *Journal of Midwifery & Women's Health*. 2010 Sep;55(5):455–61.
34. Butte NF, King JC. Energy requirements during pregnancy and lactation. *Public Health Nutr*. 2005 Oct;8(7A):1010–27.
35. Currie A. Sport and Eating Disorders - Understanding and Managing the Risks. *Asian Journal of Sports Medicine*. 2010 Jun;1(2):63–8.
36. Cakmak B, Ribeiro AP, Inanir A. Postural balance and the risk of falling during pregnancy. *J Matern Fetal Neonatal Med*. 2016;29(10):1623–5.
37. Kardel KR, Kase T. Training in pregnant women: effects on fetal development and birth. *Am J Obstet Gynecol*. 1998 Feb;178(2):280–6.
38. Weina SU. Effects of Pregnancy on the Army Physical Fitness Test. *Military Medicine*. 2006 Jun;171(6):534–7.
39. Clapp JF, Lopez B, Harcar-Sevcik R. Neonatal behavioral profile of the offspring of women who continued to exercise regularly throughout pregnancy. *Am J Obstet Gynecol*. 1999 Jan;180(1 Pt 1):91–4.

## Authors Info

Slavica Žeger: [slavicazeger@yahoo.com](mailto:slavicazeger@yahoo.com)

## Gender and Language: Assessing English Oral Skills within Sports-related Conference

Ana Penjak, Ivana Duran

Faculty of Kinesiology University of Split

### Abstract

*This article explores the issue of whether there are gender difference in oral communication skills and competences in English language, i.e. among the non-native English speakers/presenters (male and female) at the International Society for History of the Physical Education and Sport Conference (ISHPEES). The study addressed the following issues: a) are there gender differences in English oral communicative skills and competences; b) are there differences in the self-assessment and the assessment of others' English oral communicative skills and competences in presenting a paper at the Conference? A questionnaire was given to a sample of 30 conference presenters (19 male and 11 female; age  $44.4 \pm 14.7$ ) at the ISHPEES in 2015. Variable sample consisted of a questionnaire of 6 particles. The questionnaire was reliable (Cronbach's alpha 0.88, Inter-Item correlation 0.23). Gender differences were analyzed using the non-parametric statistics. Significant statistical gender differences were found in the first hypothesis regarding English oral communicative skills and competences. The results showed that the female assess their English language competences higher than the males do and, accordingly, tend to have better English oral communication skills and competences (pronunciation, syntax, vocabulary). However, results have also revealed that there is no difference between self-assessment of English oral communicative competences and the assessment of others' oral communicative skills and competences in presenting a paper at the Conference. To conclude, the study opens the door not only for further research on the topic, but also to reconsidering the choice of each teaching strategy and approach to the learners' mastery of English oral communicative skills with particular emphasis on their communicative skills and competences need for a conference paper presentations.*

**Keywords:** English, gender, communication, competences, skills, sports

## 1. Introduction

Language as our starting point from which every form of communication develops, embodies not only our personal thoughts, beliefs and ideas, but it generates personal and collective history, culture, tradition; in a word, stands as a symbol of nation's identity [12].

English as the language spoken by 330 million native English speakers worldwide [23] has gained the reputation of the 'ever present' language [19]; language that bridges the national and the global worldwide. Being the language that enjoys global reputation, knowledge of English is expected in almost all the non-native English-speaking countries (Croatia being one of them).

In all institutions (public or private) in Croatia the official language is Croatian. As such, other foreign language instructions in education, English language instruction being one of them, is a present need and a daily challenge [6]. Raos claims that 40% of newly composed Croatian words are actually English borrowings [21]. Even more, studies show that English in sport terminology in various other languages (for instance, French, German, Slovene, Serbian, etc.) is also strongly present [2,16,33,3,24]. Following these lines of thoughts, many universities and colleges in Croatia offer to their students English language courses where the emphasis is put on grammatical components (in particular vocabulary) as well as on other speech formulas and expressions (idioms, phrasal verbs, proverbs) needed for their fluent English speaking within the field of their study interest, i.e. within different contexts. For instance, students at the Faculty of Kinesiology, the University of Split, on all the study levels (pregraduate, graduate and postgraduate) are engaged in various sports-topic English language courses (some of them as mandatory courses and some of them as elective courses) where they gain, develop, practice and improve their oral proficiency as well as expand their knowledge and usage of English language structures within sports-related context.

Furthermore, every language learning process stands as a very complex and long-lasting process that requires many different skills, abilities, motivation, parental encouragement etc. [32,18]. In addition, oral communication in foreign language, in particular oral presentations on topic-oriented conferences (such as sport-related conferences), requires, as Elizabeth F. Gray and Niki Murray claim, even more practice, knowledge and experience [10,27]. Apart from language learning skills and competences, gender differences issue, as an element that tends to guide the whole process, in language learning process arises as an issue in need of further attention and analysis.

A central place in many scholarly studies and various approaches (linguistics, anthropology, psychology, education, sociology etc.) stand witness to gender differences in language learning [28,11,17,29]. Among them, there are additional studies on the issue that report on: a) female superiority in terms of foreign language learning process [7,4,31]; b) stand witness to female superiority in foreign language learning strategies in particular to foreign language oral communication [25,28,29,9]; c) underline female higher motivation for English language learning than men; d) female ability to acquire and master language elements easier and with more success [14,1].

In addition, many countries (USA; Australia, Great Britain etc.), in general, have recognized the problem of oral communication in foreign language as the key problem in the process of learning and mastering any foreign language [10]. Evenmore, Garbati and Mady state that developing oral proficiency in second language is the most vital of all language skills with particular reference to the oral proficiency within a range of various topics/contexts and academic endeavours [9].

Generally speaking, the article explores two issues: firstly, are there gender differences in English oral communicative skills and competences; secondly, can gender cause differences in the self-assessment and the assessment of others' oral communicative skills and competences in presenting a paper at, in this particular case, the International Society for History of the Physical Education and Sport Conference (ISHPEES).

## 2. Materials and methods

### *Participants*

A group of 30 conference participants (age  $44.4 \pm 14.7$ ) from 17 different worldwide countries (European, Asian, African, and North American) participated in this study. Our sample consisted of a total of 19 male (63.3%) and 11 female (36.7%) participants all non-native English language speakers. The study was conducted during the international scientific conference International Society for History of the Physical Education and Sport Conference (ISHPEES) in 2015.

### *Measurements*

In order to conduct the study a newly constructed questionnaire was used. The questionnaire consisted of 6 particles. Six statements targeted at

questioning and assessing participants' own as well as others' competences in presenting their paper at the Conference on English. The participants had to circle one particle from 1 to 10 for each of the six scales for each presenter regarding the quality of presenter's English communicative skills and the clearance of the presented content (1 meaning 'very low quality' and 10 meaning 'excellent quality'). Cronbach's alpha coefficient and Average Inter-Item correlation were calculated separately for male (Cronbach's alpha 0.96; Average Inter-Item Correlation 0.82), separately for female (Cronbach's alpha 0.93; Average Inter-Item Correlation 0.72). The questionnaire fulfilled the reliability criterion.

### *Procedure*

Testing was done on the third day (out of five) of the Conference. The questionnaire was written in English because the official language of the Conference was English. The questionnaire was given only to those participants who wanted to take part in. They were informed that the questionnaire was anonymous and subject to their will. There were no time constraints. All the participants had to assess themselves through all six particles and then repeat the procedure but assessing others' English oral presentation and skills.

### *Statistical analysis*

The data were analysed using Statistics 13 (Statsoft, USA, 2013). All variables were analysed using descriptive statistics – mean, standard deviation, mode and frequency of mode. The Mann-Whitney U Test was used to determine differences between males and females, while the differences in self-assessment and the assessment of others' (Wilcoxon Matched Pairs Test) were calculated using the non-parametric statistics.

## **3. Results and discussion**

As shown in Table 1, there are significant statistical gender differences in self-assessment component between male group and female group participants in two variables - 'pronunciation' and 'syntax' variable. Similarly, almost present statistical gender difference was found in the variable 'vocabulary' ( $p=0.06$ ). In view of Bachman's theory if the learner wants to gain proficiency in oral communication he/she should focus on two language components:



organizational (grammatical and textual) and pragmatic (illocutionary and sociolinguistic) competences [30]. Saying this, female respondents, in this study, have higher proficiency in grammatical component (i.e. syntax  $7.73 \pm 2.10$ ) and sociolinguistic component (i.e. pronunciation -  $7.31 \pm 2.07$ ) than their male participants (syntax -  $6.26 \pm 1.66$ ; pronunciation -  $6.32 \pm 1.70$ ) that, we believe, suggests their superior oral communication abilities and readiness. We assume several factors might influence the obtained results. Firstly, the process of foreign language learning is determined by different learning strategies (strategies that help and enhance learner's process of language acquisition and mastery of the foreign language in an easier, faster and less stressed way yet enabling him/her to transfer and adjust their knowledge and language use to new contexts) each individual uses independently [5]. In other words, Cohen and Dörny believe that differences in language learning strategies emerge primarily from age and gender differences [34]. Accordingly, it is believed that psychological traits (sensitivity, empathy, emotion are said to be female traits) determine each gender and, as such, affect and foster their choice of language learning strategy, i.e. his or her proficiency in oral communication as one of its strategic components [28]. Secondly, gender difference in the two variables may be in connection to social orientation and social learning strategies [20]. Namely, studies show that women are better in social orientation and, accordingly, develop more proficient oral communication skills than men [17,8].

**Table 1**

Descriptive statistics parameters (mean and standard deviation  $AS \pm SD$ ), mode and frequency mode for all the variables in self-evaluation and differences between men and women in their self-evaluation (Mann-Whitney U Test).

Self-assessment Variables	All groups			Male			Female		
	AS $\pm$ SD	Mode	F Mode	AS $\pm$ SD	Mode	F Mode	AS $\pm$ SD	Mode	F Mode
Pronunciation	$6.90 \pm 1.97$	7,00	12	$6.32 \pm 1.70^*$	7	8	$7.31 \pm 2.07^*$	7	4
Syntax	$6.80 \pm 1.94$	7,00	9	$6.26 \pm 1.66^*$	7	6	$7.73 \pm 2.10^*$	Multiple	3
Vocabulary	$6.57 \pm 1.87$	7,00	10	$6.11 \pm 1.70$	7	8	$7.36 \pm 1.96$	8	4
Compatibility with presentation	$7.20 \pm 1.65$	7,00	8	$7.21 \pm 1.32$	8	6	$7.18 \pm 2.18$	Multiple	3
Answers to questions	$6.73 \pm 1.80$	7,00	9	$6.47 \pm 1.78$	7	6	$7.18 \pm 1.83$	8	5
Fluidity in presentation	$7.20 \pm 1.79$	7,00	9	$6.89 \pm 1.66$	Multiple	5	$7.73 \pm 1.95$	7	4

*\*Statistically significant difference on the level  $p < 0.05$ ; F mode – frequency mode*



As indicated in Table 2, there are no significant statistical gender difference in the analyzed variables between male and female but there is a statistical difference between self-assessment and assessment of others' in the variable 'Compatibility with presentation' on the level of all samples. When the participants assess their own oral compatibility with presentation as well as their fluidity in presentation (Table 1), they tend to assess it with higher mark if compared to how the others assess them (Table 2). This might be explained by the fact that it is very difficult to assess our own skills and abilities objectively because to present a paper in a foreign language itself results to be highly stressful [27]. Therefore, we assume that the lower value is more objective which leave space for improvement in the field.

Different studies have addressed the issue of self-assessment (quite often related to as self-rating or self-analysis) in foreign language learning process [15,26,22,13]. Whether self-assessment is influenced by learner's comprehension of the communicative competence, his willingness to communicate, motivation or the context, all the aforementioned studies have come to a single conclusion – the study tends to be relatively underestimated and as such we cannot make a general conclusion on impacts the learner's correct self-assessment or the assessment of others' oral communicative skills. Seen from the angle of this study, we establish that the obtained results should be taken with caution.

**Table 2**

Descriptive statistics parameters (mean and standard deviation AS±SD), mode and frequency mode for all the variables in others' assessment, differences in men's and women's evaluation of others' credibility (Mann-Whitney U Test) and differences between self-assessment and others' assessment credibility (Wilcoxon Matched Pairs Test).

Others' assessment credibility	All groups			Male			Female		
	AS ± SD	Mode	F Mode	AS ± SD	Mode	F Mode	AS ± SD	Mode	F Mode
Pronunciation	6.83 ± 1.29	7,00	10,00	6.53 ± 1.39	7,00	6,00	7.36 ± 0.92	Multiple	4,00
Syntax	6.47 ± 1.36	6,00	10,00	6.42 ± 1.46	6,00	6,00	6.55 ± 1.21	6,00	4,00
Vocabulary	6.60 ± 1.38	7,00	9,00	6.32 ± 1.53	Multiple	5,00	7.09 ± 0.94	7,00	5,00
Compatibility with presentation	6.47 ± 1.33†	Multiple	7,00	6.53 ± 1.54	8,00	6,00	6.36 ± 0.92	Multiple	4,00
Answers to questions	6.80 ± 1.47	7,00	10,00	6.79 ± 1.69	7,00	8,00	6.82 ± 1.08	Multiple	4,00
Fluidity in presentation	6.97 ± 1.43	7,00	8,00	6.74 ± 1.63	6,00	5,00	7.36 ± 0.92	Multiple	4,00

† Statistically significant difference between self-evaluation and evaluation of others' credibility on the level  $p < 0.05$

Statistical analysis of the study result have provided the answers to the study questions as to whether there are gender differences in English oral communicative skills and competences, as well as whether there are differences in the self-assessment and the assessment of others' oral communicative skills and competences in presenting a paper at the Conference? The study results have confirmed that there are gender differences in participants' oral communicative skills and competences in English but only in three language components. As regards to the self-assessment and the assessment of others' oral communicative skills and competences in presenting a paper at the Conference, it has been confirmed that there are no significant statistical differences between the two.

#### **4. Conclusions**

The aim of the study was to provide insight into two issues: a) are there gender differences in English oral communicative skills and competences; b) are there differences in the self-assessment and the assessment of others' oral communicative skills and competences in presenting a paper at the International Society for History of the Physical Education and Sport Conference (ISHPEES)? The results of the study have partially confirmed the first initial hypotheses. The results suggest that there are significant statistical gender differences in English oral communicative skills and competences. The findings of the study revealed that female participants are better (as seen from their self-assessment) in three language variables (pronunciation, syntax and vocabulary components) that, we believe, influence proficiency in oral communication. However, results have also revealed that there is no difference between the self-assessment and the assessment of others' oral communicative skills and competences in presenting a paper at the Conference.

To conclude, since this study has indicated that gender and oral communication in English are interconnected, it is necessary to raise teachers' involvement and choice of instructional strategies so as to relate more effectively to gender. In so doing, teachers would be more learner-centred that would, eventually, help the learner feel more confident about his English oral skills, as well as help him express, communicate and/or present his paper at the international conference within his/her scholarly interests.

## 5. References

- [1] H. S. Aldosari, "The Entwined Effects of Attitude, Motivation and Gender on EFL Learning: A Correlation Study", *Studies in Literature and Language*, vol. 8, no. 1, (2014), pp. 1-5.
- [2] M. Benson, "English Loan Words in Russian Sport Terminology", *American Speech*, vol. 33, no. 4, (1958), pp. 252-259.
- [3] P. B. Bon, "English Words in Swiss German Usage", *American Speech*, vol. 1, no. 23, (1948), pp. 232-235.
- [4] J. P. Boyle, "Sex differences in listening vocabulary", *Language Learning*, vol. 37, no. 2, (1987), pp. 273-284.
- [5] N. Božinović and J. Sindik, "Gender differences in the use of learning strategies in adult foreign language learners", *Metodički obzori*, vol. 6, no. 1, (2011), pp. 5-20.
- [6] I. Brdar, "Engleske riječi u jeziku hrvatskih medija", *Lahor*, vol. 10, (2010), pp. 217-232.
- [7] C. Burstall, "Factors affecting foreign language learning: A consideration of some recent research findings", *Language Teaching and Linguistic Abstracts*, vol. 29, (1975), pp. 132-140.
- [8] M. L. Ehrman and R. L. Oxford, "Adult language learning styles and strategies in an intensive training setting", *Modern Language Journal*, vol. 74, no. 3, (1990), pp. 311-327.
- [9] J. F. Garbati and C. J. Mady, "Oral Skill Development in Second Languages: A Review in Search of Best Practices", *Theory and Practice in Language Studies*, vol. 5, no. 9, (2015), pp 1763-1770.
- [10] F. E. Gray and N. Murray, "A distinguishing factor': Oral Communication Skills in New Accountancy Graduates", *Accounting Education*, vol. 20, no. 3, (2011), pp. 275-294. doi: 10.1080/09639284.2011.560763
- [11] J. M. Green and R. L. Oxford, "A closer look at learning strategies, L2 proficiency, and gender", *TESOL Quarterly*, vol. 29, no. 2, (1995), pp. 261-297.
- [12] J. Gvozdanović, "Jezik i kulturni identiteti Hrvata", *Kroatologija*, vol. 1, no. ), (2010), pp. 39-57.

- [13] R. Leblanc and G. Painchaud, "Self-Assessment as a Second Language Placement Instrument", *TESOL quarterly*, vol. 19, no. 4, **(1985)**, pp. 673-687.
- [14] H. Lee and Y. Kim, "Korean adolescents' longitudinal change of intrinsic motivation in learning English and mathematics during secondary school years: Focusing on gender difference and school characteristics", *Learning and Individual Differences*, vol. 36, **(2014)**, pp. 131-139. doi:10.1016/j.lindif.2014.07.018
- [15] P. D. MacIntyre, K. A. Noels, R. Clément, "Biases in Self-Ratings of Second Language Proficiency: The Role of Language Anxiety", *Language Learning*, vol. 47, no. 2, **(1997)**, pp. 265-287.
- [16] T. McClintock, "English and American Sport Terms in German", *American Speech*, vol. 8, no. 4, **(1933)**, pp. 42-47.
- [17] R. L. Oxford M. Nyikos, "Variables affecting choice of language learning strategies by university learners", *Modern Language Journal*, vol. 73, no. 3, **(1989)**, pp. 291-300.
- [18] A. Penjak H. Karninčić, "Attitudes, Motivation and Parental Encouragement in Learning English as a Foreign Language: the Croatian Context", *Journal of Foreign Languages, Cultures and Civilizations*, vol. 3, no. 2, **(2015)**, pp. 17-23.
- [19] A. Penjak, "From Local to Global - An Overview of the Croatian National Theatre in the Era of Globalization", *Collegium Antropologicum*, vol. 36, no. 3, **(2012)**, pp. 981-986.
- [20] R. L. Politzer, "An exploratory study of self reported language learning behaviors and their relation to achievement", *Studies in Second Language Acquisition*, vol. 6, no. 1, **(1983)**, pp. 54-68.
- [21] N. Raos, "O potrebi razlikovanja hrvatskog i engleskog jezika", *Arh Higijena Rada Toksikol*, vol. 57, no. 4, **(2006)**, 405-412.
- [22] S. Ross, "Self-assessment in second language testing: a meta-analysis and analysis of experiential factors", *Language Testing*, vol. 15, no. 1, **(1998)**, pp. 1-20.
- [23] S. Rukh, "Students' Attitude towards English Language Learning and Academic Achievement: A Case of Business Students in Punjab", *European Academic Research*, vol. 2, no. 4, **(2014)**, pp. 5596-5612.
- [24] I. Stramljič Breznik and I. Voršič, "Word-formational productivity of the Slovene language in the case of sports neologisms", *Linguistica*, vol. 51, no. 1, **(2011)**, pp. 23-38.

- [25] Q. Wang, "A Study of the Influence of Gender Differences on English Learning of Senior High School Students", *Higher Education of Social Science*, vol. 8, no. 6, (2015), pp. 66-69.
- [26] T. Yashima, "Willingness to Communicate in a Second Language: The Japanese EFL Context", *The Modern Language Journal*, vol. 86, no. 1, (2002), pp. 54-66.
- [27] J. Zascerinska, "Efficiency of English for Academic Purposes Activity in Students' Language Education: Developing the System of External and Internal Perspectives", (2010), Online Submission.
- [28] S. Zeynali, "Exploring the Gender Effect on EFL Learners' Learning Strategies", *Theory and Practice in Language Studies*, vol. 2, no. 8, (2012), pp. 1614-1620.
- [29] M. Zoghi, S. A. Kazemi and A. Kalani, "The Effect of Gender on Language Learning", *Journal of Novel Applied Sciences*, vol. 2, no. 54, (2013), pp. 1124-1128.
- [30] L. Bachman, *Fundamental Considerations in Language Testing*, Oxford University Press, Oxford, (1990).
- [31] S. Ehrlich, *Representing Rape: Language and Sexual Consent*, Routledge, London, (2001).
- [32] L. Ilyinska, *English for Science and Technology: Course Design, Text Analysis, Research Writing*.  
Monograph", RTU Publishing House, Riga Technical University, (2004).
- [33] I. J. Konya, "A Morphological Analysis of Loanwords in Russian. MA Thesis", University of British Columbia, Canada, (1966).
- [34] A. D. Cohen and Z. Dörny, Focus on the language learner: Motivatin, styles, and strategies", Edited N. Schmitt, *An introduction to applied linguistics*, Arnold, London, (2002), pp. 170-190.

### Authors Info

Ana Penjak: [ana.penjak@kifst.hr](mailto:ana.penjak@kifst.hr)

# Qualitative Examination of Socio-Psychological Aspects Affecting Volleyball Setters Pre-Match Preparation

Tea Gutović, Boris Milavić, Zoran Grgantov

*Faculty of Kinesiology, University of Split*

## **Abstract**

Volleyball setters are often metaphorically called “coach’s extended arm on the court”, which, along with specific motor skills and functional abilities, points out the need for specific psychological and social characteristics of players specialized for this position.

The results obtained in this study are based on conducted semi-structured interviews with 10 setters from five Dalmatia’s volleyball women teams playing in the national first league. Study suggested the lack of psychological preparations elements in the regular training process. Psychological preparation is least represented in the competition micro-cycle, coaches do not devote enough time to prepare players for important matches, and they rarely separate setters’ preparation from the rest of the team. Therefore, setters are mainly oriented on self-preparation for important matches, using method of remembering tactical information about the opponent or using basic techniques of psychological preparation, such as visualization and self-talk, as well as depending on their teams cohesion and close interactions with other team members. However, in their assessment of readiness for important matches, the sense of confidence prevailed the sense of anxiety among interviewed setter, and they assessed their technical and tactical readiness as sufficient, but psychological readiness as mediocre.

**Keywords:** socio-psychological aspects, volleyball, setter, pre-match, semi-structured interview

## **1. Introduction**

The process of training in the domain of professional sport has developed its methods, techniques and preparation procedures on a technical, tactical

and on the level of physical condition almost to perfection, but in competitions and in conclusive results there are still differences between athletes [3]. Therefore, a question of what differs a highly successful athlete from a less successful one is brought up in modern kinesiological research. The answers are mostly looked for in the area of mental toughness [11]. The negative ratio between psychological and the technical- tactical- condition preparations in volleyball training process in Croatia could be the consequence of wider social problems related to this sport. In fact, volleyball in Croatia is placed inside the framework of recreational sport according to the definitions by the authors Perasović and Bartoluci, considering how often it presents only a spare time activity for its participants, while the people which consider volleyball their main source of income and a profession, including players, coaches and other professional staff, are a minority [15]. This part of sports preparation is just recently becoming a part of professional education of sports staff, so it can be presumed that it is actually the lack of knowledge of their coaches which causes athletes to rely solely on their own motivation, emotional stability and mental strength during competitions. The process of psychological preparation for athletes is mostly focused on building motivation, increasing self-confidence, relieving stress and anxiety in competitions, using mostly some of the basic techniques of psychological preparation, such as visualization, breathing techniques, relaxation, blocking negative thoughts and self-talk [2]. With condition and technical-tactical preparation, a coach should, as the leader through the match, with the help of experts and sport psychologists, teach his players about psychological preparation [11] and guide them into understanding social interactions of the team. This should be done in both younger teams and in competitive, senior teams.

The position of a setter in volleyball could be compared with the one of a quarterback in American football or a playmaker in basketball. It is a position which organizes the game and converts the tactics given by the coach into the game itself, leading their teammates through the game. A setter is the primary performer of offense in a volleyball team. With specific technical-tactical knowledge, a player at this position should also have specific psychological and social skills to be efficient. This position is described as the most important one in a volleyball team, pointing out how these players should be described with the qualities of the creator of the game, "the architect" and the decision maker and also described with the characteristics of willingness for collaboration, increased perception, mental strength, stability, diligence,

discipline and awareness [10]. Furthermore, setter should demonstrate the qualities of a leader, should be in good relations with the players and be open to collaboration and acquisition of knowledge. The characteristics of a leader are manifested through successful game organization, implementation of the tactics, adjustments to his own team and finding the weak spots of the opponents. All of that would not be possible without profound knowledge about the game itself, tactics and the many options volleyball offers, which a player in that position learns through a long training process and playing experience [7]. The qualities of a setter can be summed up in the following three: leadership, confidence and intelligence. Including those three, an American volleyball coach and volleyball theoretician, John Kessel also points out emotional stability and the “sponge” ability to listen and respond to teammates feedback. So, a great part of the success of a volleyball team depends on the psychological state of a setter and the quality of interactions he has with the rest of the team. Although the setter is rarely given credit for scoring a point, he is often blamed for a failed offence or a missed spiked ball and this is exactly why he must have a high level of emotional stability, confidence and intelligence in order to deal with the burden of “other people’s” mistakes [8]. Setter must be prepared to take responsibility, to give his team the right level of security, to know how to communicate and connect with the team and make quick and correct decisions in the right moment. All of this is only possible if the player in that position is prepared to set aside his ego, subject to the success of the team and most often play without directly scoring a point. In the same time, a setter must have a high-enough level of confidence and motivation and to know his importance and role in the team, to guide and correct it, to fool the opponent and to make gaining an advantage over their opponents easier for his or her team [5].

Alongside the individual characteristics of a setter, it is important to point out that volleyball is a team sport therefore social interactions among team members can not be neglected. A sports team is first and foremost a social group characterized by specific social relations, emotions and behavior. Social relations inside a sports team can be: cooperative, competitive, conflictive, relations of adaptation and relations of assimilation. The goal of the coach in the training process should be guided towards the transformation of the team from a secondary social group to a primary one for each of its members. Therefore, a team as a primary social group would be characterized by a strong feeling of collectiveness, an intimate, personal connection of the members, a



feeling of safety, content with belonging and involvement on the level of their whole personality. Collectiveness is an impalpable quality that brings together a group of individuals into a social group, guiding them towards a common goal [1].

Qualitative research in kinesiology are relatively rare, and they are characterized by conducting research in natural surroundings and application of different methods that emphasize interactivity and humanistic approach, and also variability and adaptation of the research design to the circumstances on the field. They are still done on the borders of interdisciplinarity, including anthropological, sociological or psychological perspectives and research questions inside the framework of sport activity. Also, unlike quantitative, they do not demand a large number of participants and generalizations of results. Moreover, they aspire towards a naturalistic approach to the research context in its "natural form" [4]. By using qualitative approach in this research, the aim was to understand subjective perspectives and the deeper meaning that setters give to the aspect of psychological preparation in the training process, and the main goal itself was to examine familiarity and use of psychological preparation in the training process of first league volleyball teams in Dalmatia.

## 2. Materials and Methods

### *Participants*

The participants were ten players at the setter position in senior teams of Dalmatian volleyball clubs which, in the season of 2016./2017., played in the 1.A Senior National volleyball league. The interviewed setters play in five clubs (VC Brda, VC Kaštela DC, VC Zadar, WVC Dubrovnik and VC Marina Kaštela).

The interviewed technicians have been training, on average, for about nine years ( $M=9.1$ ;  $sd=3.51$ ), and the sample, according to the situation in the clubs, divided evenly to five juniors and five seniors, meaning the players somewhat younger than 20 and those in their early twenties ( $M=19.4$ ;  $sd=3.09$ ).

### *Measurements*

The research was conducted with the method of a semi-structured interview, using a questionnaire with 21 open-ended questions. The first eight questions referred to player categorization, and to gaining basic information about their training experience and status. With the introductory questions

about training status, player experience and the age of specialization, the questions in the interview can be divided into three groups:

- the role of the coach in psychological preparation for competitions (this refers to the articulation of the influence a coach has on the psychological preparation before important matches, the portion of psychological preparation in the microcycle during competitive periods and also the specificity of setter's preparation in comparison to the rest of the team),
- independent preparation of players for matches (focused on the individual knowledge of the psychological preparation aspect, participation in the same and individual ways and techniques players use for preparation),
- evaluation of personal competence before important matches (refers to self-evaluation of competence of setters before a match, considering all the previous responses and assessments on the coach's influence and individual approach).

All the questions referred to preparation before important matches, the so called „derbies“, with the assumption that those matches are a bigger source of stress and anxiety and that they are characterized by a high level of motivation in the players which were questioned.

### *Procedure*

The importance of qualitative research is in providing deeper meaning and understanding of some phenomena and occurrences in sport and in social groups existing in sport. So, a research on personal preparation of setters in volleyball was conducted with a qualitative approach, in the framework of social sciences of sociology and psychology, all with the aim of providing insight into the current status of the training process of volleyball teams and the subjective attitude of setters towards the importance of psychological preparation.

By using the method of a semi-structured interview in which all questions were open-ended questions, with the possibility of categorizing answers, the research was provided with a high level of structurality in order to gather the needed information but also openness to present the genuine depiction of the world from the perspective of the players which were questioned. The aim of using this method was, in regard to our research focus, to provide the participants the freedom to express themselves, to clarify the meaning they

give to certain ideas and concepts and to provide a deeper understanding of the significance of the ideas being researched [17].

The research was conducted during October and November 2016 in Dalmatia, in Split, Kaštela, Zadar and Dubrovnik. The interview was completely anonymous, it was done face-to-face and recorded with an audio recorder with the permission of each of the participants, and in the case of a minor, with the permission of the parents which were also present during the interview. The interviewer wrote down answers during the interviews which she later corrected while listening to the recordings. During the interviews of four minor setters, their mothers were present and they could also state their attitudes or experiences about the topic of research, which one of them did.

### *Statistical analysis*

According to the qualitative methodology of the research, during the analysis of data no statistical tests were used to interpret the results. Considering that this research has 10 participants, all the gathered data can be interpreted in the framework of descriptive statistics, by presenting prevalence (frequency and percentage) of each individual answer. Mean and standard deviation shown for some answers serve the purpose of adequately presenting characteristics of sample and are not appropriate for doing more complex statistical tests.

## **3. Results and discussion**

Among the interviewed participants, there were six adult and four minor setters. The average age of the participants is slightly above 19 ( $M=19.4$ ;  $sd=3.09$ ). Two of the youngest participants from WVC Dubrovnik and VC Zadar are 16 years old and the oldest from VC Brda is 24 years old. Four of the participants are in their teams starting lineup, four are substitutes and two setters pointed out that it depends on the change their coach makes each week (Table 1). Their status in the team does not depend on their age group, considering that in two clubs both juniors compete in the first league as setters, although we can conclude that older players are mostly part of their teams starting lineup. Setters, on average, play in this rank of competition for about three years ( $M=2.7$ ;  $sd=2.05$ ), and this average is quite increased by the players of VC Kaštela DC and VC Brda that have been playing for five and for

seven years. But also, there are four setters that have been playing in the first league for just a year (Table 1). The listed data can be compared to the overall training experience of setters - the age when they started training. Two setters started playing volleyball when they were 8, one when she was 9, five of them when they were 11 and two when they were 12, so they are on average playing volleyball for slightly above 10 years ( $M=10$ ;  $sd=1.51$ ). Specialization for the position of a setter for the participants usually started after about four years of training ( $M=3.95$ ;  $sd=2.14$ ), at the average age of 14 which marks the beginning of high school education and, for most players, the beginning of competing for their clubs (Table 1).

**Table 1. Status in the Team and Training Experience of Setters**

PARTICIPANTS	status in the team	age when they started training		age of specialization		training experience (in years)		first league experience (in years)	
		Min	max	min	max	min	max	min	max
1	starting lineup	11	16	12	5	3	1		
2	substitutes	11	14	13	7				
3	depending on the decision of the coach	8	14	11	3				
4	substitutes	12	12.5	5	1				
5	starting lineup	9	14	14	1				
6	depending on the decision of the coach	11	18	11	4				
7	starting lineup	12	14	5	2				
8	substitutes	11	14	5	1				
9	substitutes	8	14	8	1				
10	starting lineup	11	13	7	2				
		<b>Min</b>	8	<b>min</b>	12.5	<b>min</b>	5	<b>min</b>	1
		<b>Max</b>	12	<b>max</b>	18	<b>max</b>	14	<b>max</b>	7
		<b>M</b>	10.4	<b>M</b>	14.3	<b>M</b>	9.1	<b>M</b>	2.7
		<b>Sd</b>	1.51	<b>sd</b>	1.56	<b>sd</b>	3.51	<b>sd</b>	2.05

\* Seniors = dark grey; Juniors = light grey.

According to the listed data, it is hardly possible to observe and study the first Croatian volleyball league as a professional league and to consider the participants as professional volleyball players. The results of authors Kitsantasa and Zimmerman point out the differences in psychological processes between professional players, amateurs and beginners, especially in the aspects of self-evaluation, motivation and confidence in their own performance. Professional volleyball players dedicate more of their time to the training process, they subject other activities to volleyball and show a higher level of psychological tranquility in practices [9]. Taking this into account, when interpreting the results of this research, it is important to consider the social context in which the participants play volleyball. Although they have a semi-professional volleyball career, we can not ignore the effects of everyday activities to the training process and the possibility of psychological preparation, such as duties in school or in college.

### *The Role of the Coach in the Preparation of Setters*

As most of human relations, the coach-player relation consists out of interactions. One of the key tasks a coach has in that relation is to create an adequate work environment in which a player will make advances in regard to her condition, technical, tactical and psychological state and also acquire new knowledge and skills. Although there are significant differences in the coach-player diad between individual and group sports, the developed 3+1C model presents the aspects of that relation on an emotional, cognitive and behavioral level. This model of the coach-player relation was named after the English words closeness, commitment, complementarity and co-orientation, where the action of the coach on any of these three levels should be accompanied by a reaction of the player, with understanding and similarities in understanding their relation but also with a common sport goal [6].

The described coach-player relation definitely affects the individual psychological development of players but also the improvement of the entire team as a social group. Most of the interviewed setters, six of them, think that their current coach does not spend enough time on psychological preparation of players before important matches. It is mostly "*a brief conversation on Friday before the game*" (interview 9). Depending on the state of the team and of the opponent, some coaches "*either lift up our mood or calm and focus us*" (interview 2.) In almost all interviews it is noticeable how players identify psychological

with tactical preparation. Three setters point out how the coach prepares the team by explaining as many opponent's actions as possible, which provides the players "*psychological assurance*" (interview 6), while one of the setters especially points out that that tactical preparation is not sufficient because during a match and training the coach undermines their confidence and does not motivate them. It is interesting to point out how, out of the four players that think their coach dedicates enough time to psychological preparation before important matches, two think that "*too much time is dedicated to it*" (interview 4). In these examples, we have coaches that individually talk to some players according to their current state, they guide the players on how to spend the match day and acquire emotional stability and also encourage collectiveness in the team by telling the players "*to play for each other, to get the fruits of their labor, to enjoy*" (interview 4).

It is indicative to point out how the players that play for the same club and in the same team, hence they are coached by the same coach, have different perceptions on the necessity of psychological preparations before competitions, which affirms the need for individual access in this part of the training process. Studies have shown that coaches in individual sports show more empathy, apropos a bigger ability of understanding feeling and psychological conditions of their players, while in team sports the listed characteristics of a coach influence the individual access to each player of the team [14]. Nevertheless, eight setters do not notice an individual access of the coach in accordance with the demands of their position. Only two of the participants stress out how their coaches separate the preparation of setters from the preparation of other players, although in this case these preparations are on the border of tactical and psychological preparation. The coaches then "*point to the key players in the opposing team, to whom to set in the following rotation*" (interview 1), and guide them to follow the situation in their own team, "*to see who is in the mood, to whom to give the crucial ball*" (interview 6).

The variability in the perception of the necessity of psychological preparation shows the subjective understanding of setters and their individual need for it. On the concrete question about the percentage of technical, tactical, condition and psychological aspects during competitive microcycle (out of the overall 100%), in most assessments of the participants, the technical ( $M=49.0$ ;  $sd=19.11$ ) and tactical ( $M=24.7$ ;  $sd=15.83$ ) are dominant, although within these elements there is a high variability. The technical preparation varies from 30% to 90% and tactical from 0% to 50% (Table 2). Condition preparation,

according to the assessment of the interviewed setters, is more represented than psychological preparation in the competitive microcycle, although still significantly less than the technical-tactical preparation and it varies from 10% to 30% ( $M=18.2$ ;  $sd=7.99$ ). Therefore, if we divide the typical competitive microcycle in Dalmatian volleyball first league teams into technical, tactical, condition and psychological preparation, we can conclude that coaches spend half of their time on technical preparation, a quarter on tactical, somewhat less of a fifth to condition, while they spend under a tenth of their time on psychological preparation during competitive periods ( $M=8.0$ ;  $sd=5.87$ ) (Table 2). In the aspect of psychological preparation, the answers given by the setters vary the least. None of them states more than a 15% of time on psychological preparation, regardless the already analyzed individual assessment of the need for it.

Assessment of the percentage of each of the given aspects of preparation is different with senior setters and junior setters (Table 2.) Seniors estimate a bigger percentage of tactical, condition and psychological preparation while juniors emphasize a bigger percentage of technical preparation. The explanation can be found in a longer training process of seniors who have also been competing in the same rank of competition for a longer period of time. That provides a more objective assessment of the training process and better perception and acknowledgment of its various aspects. Juniors still mostly perceive themselves through the technical performance of volleyball elements so they consider that aspect the most represented in the training process.

Changes in the percentages of technical, tactical, condition and psychological preparation just before an important match, a "derby" are not pointed out solely by one setter, but those are mainly the changes that pretty much emphasize tactical preparation against the opponent. Nevertheless, three setters pointed out how before important matches coaches dedicate slightly more time to psychological preparation through "*individual preparation of key players*" (interview 5). Also, during the preparation for the derbies, one of the setters stresses out the collectiveness of the team, shown through mutual help among the players where the players "*talk to one another about various elements of the game*" (interview 7). This confirms the importance of the element of collectiveness in group sports. Players can not solely rely on the coach, but also have to know and understand that their final success depends on the entire team, which creates dependence and trust among players [6].

**Table 2. The Percentage of Technical, Tactical, Condition and Psychological Preparation in the Training Process**

preparation (%) participant	technical	Tactical	condition	psychological	RESULT
1	35	20	30	15	100
2	30	40	20	10	100
3	45	25	30	0	100
4	35	25	25	15	100
5	40	35	15	10	100
6	60	12,5	12,5	15	100
7	90	0	10	0	100
8	35	50	10	5	100
9	50	35	10	5	100
10	70	5	20	5	100
<b>Min</b>	30	0	10	0	//
<b>Max</b>	90	50	30	15	//
<b>M</b>	49.0	24.7	18.2	8.0	//
<b>Sd</b>	19.11	15.83	7.99	5.87	//
<b>SENIORS</b>					
<b>M±Sd</b>	42.0±11.51	26.5±11.12	21.5±8.21	10.0±6.12	//
<b>JUNIORS</b>					
<b>M±Sd</b>	52.0±23.82	23.0±20.79	15.5±7.07	6.0±5.47	//

*Individual Preparation for Matches*

To even analyze forms and ways of individual preparation of setters in first league clubs from Dalmatia before important matches, it is necessary to first gain insight into their first encounter with psychological preparation in sport. Two of the setters have not, until now, known anything about psychological preparation of athletes, while others are, more or less, informed on the basic meaning of this aspect of the training process. They have gained that information through conversation with their parents or some of their ex-coaches. Two of the participants point out conversation with their parents who, themselves, were athletes or coaches as their first encounter with terms of psychological



preparation, such as motivation and concentration, i.e. *“through conversation with my mother (...) when I started participating in competitions, she started to talk to me about preparing for matches, thinking about matches, having a positive attitude and so on”* (interview 5). Other setters have, with at least one of their coaches, learned about the aspect of psychological preparation, most of them at the beginning of their competitive career. Concrete work with a sports psychologist in their career so far is pointed out only by two participants: *“we had group work to improve our solidarity, to learn to read each other’s thoughts, and we had individual sessions at least once a week”* (interview 3), which was accompanied with some of the techniques of psychological preparation: *“we would lay down in the dark with some music playing and the psychologist would “turn on the light” inside us, light would go through our bodies and we would relax that way, and sometimes we would work on visualization”* (interview 2).

With the instructions of the coach, preparing for matches is also a task for each player individually, whether it is about recollecting the coach’s instructions, developing solidarity with the rest of the team or individual psychological preparation by using different techniques. Each of the interviewed players starts to individually contemplate on the game at least a day earlier, therefore on Friday and two players even contemplate on a forthcoming game for weeks in advance (Table 3). Although there is no accepted theoretical pattern on when it is most adequate to start preparing psychologically and contemplating on a game, application of some of the techniques, such as relaxation and visualization, is recommended at least a couple of days before the competition [11], which actually all participants do by starting to contemplate on the forthcoming game either on the beginning of the week or in the middle of it.

**Table 3. Time of the Beginning of Contemplating on an Important Match**

	SENIORS	JUNIORS	TOTAL	
			f	%
couple of weeks in advance	2	0	2	20
beginning of the week	1	2	3	30
middle of the week	1	1	2	20
Friday before the match	1	2	3	30
morning of the match	/	/	/	/
couple of hours before the match	/	/	/	/
when entering the court and during warm- up	/	/	/	/
I do not think about the game until I start playing it	/	/	/	/

By comparing the time when players start to individually contemplate on important matches with their age group, it is noticeable how seniors start earlier than the juniors who mostly do it in the week of the match. This can relate to a bigger training and competitive experience of seniors, who, based on it, can estimate how much individual preparation they need in order to be ready on the day of the match. Furthermore, the already mentioned earlier start of contemplation in seniors can indicate a higher level of responsibility and cognitive anxiety, but also the readiness of setters to devote themselves, on a deeper level, to their individual preparation by thinking about as much tactical solutions as they can. If we take into account how seniors are mostly in the starting lineup, it is expected that they feel a greater responsibility. The frequency of contemplation on an important match gets bigger as the game day is approaching, so all the interviewed setters think about it intensively during the day of the match, nine of them often think about it on Friday and half of them even on Thursday. We can conclude that Wednesday (if the important match is played on Saturday) is the breakeven point in the microcycle for the beginning of setters' preparation for the match.

During setters' individual preparation, they mostly remember previous games with the same opponent, some tactical solutions that might improve their abilities, but also abilities shown by their teammates: *"I focus on the instructions of my coach about the opponent, I think about what I, as an individual, can do in which rotation to take advantage of the weaknesses of the opponent"* (interview 2). One of the participants starts contemplating on an important match weeks in advance and has different approaches to it *"depending whether she is excited or calm"* (interview 3) but also focuses on thinking about the opponent and the possible tactics that can be used. Two of the setters pointed out how they try to focus as much as possible on trainings before important matches, to correct some of their previous mistakes and release tension.

Along with the method of remembering their opponent, if they have already played against them, half of the interviewed setters in their individual preparation, use video recordings of previous games, whether that is a part of the training process: *"we watch recordings of the opponents if we have them"* (interview 7) or they individually devote themselves to certain techniques, such as visualization or relaxation techniques: *"nothing special, with remembering the opponent I use a lot of visualization"* (interview 6), *"I do some breathing exercises"* (interview 3), *"with regular hard work on practices, my aim is just to calm down"* (interview 4).

In the aspect of individual psychological preparation, the interviewed setters mostly stress how their goal is to gain as much concentration on match day as possible. Most of them achieve it by having certain routines on that day: *“I plan my entire day in detail, from when I get up in the morning until I get on the court and I try to stick to that schedule”* (interview 6). All of their previously acquired form is intensified on the day of the match, they try *“to be in top shape on the day of the match, well rested and ready”* (interview 3). Also, they point out conversation to their teammates as an important element of psychological preparation: *“they encourage, motivate and really help me”* (interview 8) and they try to *“mutually encourage one another, warn each other about our possible mistakes and things like that”* (interview 1). It is interesting to indicate how a few of the interviewed setters try to remember their previous mistakes in order to not to do them again. This can cause an opposite effect and decrease their confidence and increase anxiety and fear from making the same mistake again.

**Table 4. Techniques Used in Individual Preparation**

	familiarity		usage	
	f	%	f	%
visualization	8	80	7	70
breathing techniques	6	60	1	10
relaxing	6	60	2	20
blocking negative thoughts	6	60	4	40
self-talk (positive thoughts)	7	70	7	70
(other)  table describing positive and negative characteristics of athletes	1	10	1	10

The concrete familiarity of setters with techniques of psychological preparation is on a very high level. Most of them are familiar with all the basic techniques of psychological preparation. One of the setters, due to her extensive work with a sport psychologist in her previous club, points out her preparation technique in the form of a scale which helps her to estimate her current mental state that motivates her and improves her concentration (Table 4). On the other hand, the use of basic techniques is on a somewhat lower level.

Visualization, soliloquy and positive thinking are methods used by seven of the interviewed setters while four of them regularly use the technique of stopping negative thoughts (Table 4). It is important to point out how in most cases where these techniques are used, the setters are not fully familiar with their principles and rules, but use just some of the basic elements of the techniques.

In the final part of the interview, setters estimated their general readiness before going in the court and the beginning of an important match, "derby". Although the level of confidence a player has is individual and dependent on numerous characteristics of their personality, before a competition it mostly depends on the previously completed psychological preparation whether it was led by a coach or it was individual. Similar can be said about the level of anxiety, which appears in stressful situations and an inadequate approach of the coach for important matches and bad relations in the team can quite increase it and undermine the performance. A research conducted by authors Raglin and Morris on the differences between the estimated level of anxiety of volleyball players before important matches and the real anxiety they feel, points out to a great ability of an individual to oversee and to remember the level of anxiety before a match which gives reliability to the results of this research [16].

According to the results of the conducted research, a feeling of confidence dominates among setters of first league clubs in Dalmatia before an important match. Six of them describe it as average. But still, it is not to be ignored how two setters pointed out how they do not have any confidence before a match and also other two setters would rate their confidence as high. A great variability in the feeling of confidence is definitely a result of differences in training processes and approaches the coaches have and it is necessary to mention how the two youngest players, one in the starting lineup and the other one as a substitute, have the lowest level of confidence (Table 5). The feeling of anxiety is present with all players. Most of them estimate it as low (three participants) or average (two participants) while two setters have a high level of anxiety and two have a very high level. One of the players who estimated how she has no confidence at all is also one of the two who have the highest level of anxiety. Moreover, younger setters and those with less first league experience and in the starting lineup of their team estimate their level of anxiety higher than older and more experienced players (Table 5). The listed results greatly prove the results of a research conducted on 286 Croatian volleyball players (106 men and 180 women) in 2013. According to that research, older volleyball players

(juniors) show a higher level of confidence than cadets but also a higher level of somatic and cognitive anxiety [12]. The setters have also pointed out, during the interviews, the social circumstances of playing an important game such as performing in front of supporters or the presence of their parents and close friends as an additional influence to the level of confidence and anxiety.

**Table 5. Assessment on Confidence and Anxiety Level Before Important Matches**

	confidence		anxiety	
	<i>f</i>	%	<i>f</i>	%
none	2	20	0	0
low	0	0	3	30
average	6	60	3	30
high	2	20	2	20
very high	0	0	2	20

In addition to estimating levels of confidence and anxiety, setters also estimated their own feeling of readiness for an important match on a technical, tactical, condition and psychological level and the general readiness taking into account all the aspects of the training process and individual preparation. The general readiness of setters, setting aside assessments of lack of confidence and increased anxiety and the emphasized need for increasing psychological preparation by the coaches, is for seven of them on a satisfactory level and they use expressions such as “substantial” and “plenty” when describing it (Table 6). In accordance with the expectations and also with percentage of technical preparation in the training process, setters feel most competent on that level, followed by tactical readiness. Psychological readiness, just like its percentage in the training process, is at the lowest level, although none of the setters feels that she is completely not ready or that she is completely ready. The variability of self-assessment on this level is between “little” and “plenty” while actually most of the setters (6) are averagely ready. Although previously conducted research has shown a substantial difference in psychological readiness of excellent players and amateurs [13], we can notice the lack of psychological preparation during the training process and its effects on the performance of players in competitions. We can conclude that the need for sport psychologists in volleyball teams or alternative training of coaches about the psychological elements of this sport is equally needed as condition preparation and technical-tactical development.

**Table 6. Assessment of Competence of Setters Before Important Matches**

	none (0%)		little		Somewhat		average		substantial		plenty		completely (100%)	
	<i>f</i>	%	<i>f</i>	%	<i>f</i>	%	<i>f</i>	%	<i>f</i>	%	<i>f</i>	%	<i>f</i>	%
<b>overall</b>	0	0	0	0	1	10	2	20	2	20	5	50	0	0
<b>technical</b>	0	0	0	0	0	0	1	10	6	60	1	10	2	20
<b>tactical</b>	0	0	1	10	1	10	1	10	2	20	4	40	1	10
<b>psychological</b>	0	0	1	10	3	30	3	30	1	10	2	20	0	0

#### **4. Conclusions**

The setter position in volleyball is specific not only by player's necessary motoric and functional abilities, but for the characteristics of a person, by the socio-psychological profile an individual specialized for this position should have. It is often said that setters are players "without blood", they rarely score points directly, but at the same time they assist for those points and they are the ones responsible for winning them. So, the status of a team playmaker, who the setter is, is often crucial for the success of the entire team. His stability, motivation and confidence is transferable to the entire team and brings in to a positive sport result.

In accordance with the given aims, this work explored the familiarity and application of psychological preparation in the training process of first league volleyball teams in Dalmatia. According to the conducted interviews with 10 setters, we can conclude that this aspect of the training process is very much neglected. Although the participants make a heterogenic group according to their training experience and age of specialization, these are players that have been playing volleyball for a minimum of five years and have changed at least one coach in their career so far. Through the given specific aims, the research was focused on the role of a coach in psychological preparation of technicians for "derbies" and players' own individual preparation for them, which participants mostly identify with tactical preparation for the opponent. They also point out the lack of specific preparation for them as setters in relation with the rest of the team.

The lack of involvement of the coaches is somewhat made up for by the players themselves with individual preparation for matches. Most of them are familiar with the basic techniques of psychological preparation for matches, such as visualization, breathing and relaxing techniques, stopping negative thoughts and they use them regularly when preparing by themselves. Nevertheless, it is mostly a superficial understanding of the proper way of performing these techniques. Players, during individual preparation, usually try to focus, remember tactical information on the opponent and relieve stress and anxiety. We can not ignore the aspects of group cohesion that the interviewed setters use in preparation for important matches, especially the feeling of collectiveness with the teammates and the possibility of closely interacting with them. Finally, despite the emphasized lack of knowledge on psychological preparation and the exposure of it in the training process, interviewed setters still feel quite prepared for important matches (derbies), mostly on a technical and tactical level. Most of them feel confident before a match, although there is a certain amount of anxiety present with all of them.

As one of the possible reasons for the confirmed lack of time, resources, competence and interest in psychological preparation, by both the coaches and the players in volleyball, we can certainly point out the social context of playing volleyball semi-professionally in Croatia. Namely, which the pattern in this research proves, in first league clubs the players who are still in high school, college or have jobs are playing which makes sport a secondary life activity, an aspect of leisure. Nevertheless, it is crucial to point out how that is neither a justification or the reason for the lack of systematization of psychological preparation in volleyball clubs and the fact that players must rely solely on their own motivation to exceed and desire to improve this aspect of their training process. Croatian sport in general, including volleyball, is characterized by a lack of systematization in educating professional personnel on the social and psychological aspects of sport, which sometimes have the same effect on the final outcome as technical-tactical knowledge and condition abilities. There is a reason why sport is defined as a social, physical and mental activity, stressing out the necessity of equal improvement of physical and socio-psychological aspects of an athlete's character from an earliest age.

## 5. References

- [1] Bjelajac, S. (2006). *Sport i društvo*. Split. Redak.
- [2] Burton, D., & Raedeke, T. D. (2008). *Sport Psychology for Coaches*. Champaign: Human Kinetics.
- [3] Davies, D., & Armstrong, M. (2005). *Psychological Factors in Competitive Sports*. London, New York: The Falmer Press.
- [4] Denzin, N.K. & Lincoln, Y.S. (Eds.). (2005). *Handbook of Qualitative Research* (3<sup>rd</sup> ed.). London: SAGE Publications.
- [5] Johnson, C. (2009). Taking Your Setter From Good to Great: Seven Qualities for Which to Strive. *AVCA Coaching Volleyball Magazine*. Retrieved from [http://www.virtualonlinepubs.com/display\\_article.php?id=229908](http://www.virtualonlinepubs.com/display_article.php?id=229908).
- [6] Jowett, S. (2007). Coach–athlete relationships ignite sense of groupness. In M.R. Beuchamp & M.A. Eys (Eds.), *Group Dynamics in Exercise and Sport Psychology. Contemporary Themes* (pp. 63-77). London, New York: Routledge.
- [7] Kane-Hopton, P. (2015). *Recipe for a Setter*. Retrieved from <http://www.teamusa.org/usa-volleyball/education/coaching-education-programs/resources/cap-ii-articles/recipe-for-a-setter>.
- [8] Kessel, J. (2010). *Thoughts for Setters*. Retrieved from <http://www.teamusa.org/USA-Volleyball/Grassroots/SportKit/Player-Resources/Thoughts-for-setters>.
- [9] Kitsantas, A., & Zimmerman, B.J. (2002). Comparing Self-Regulatory Process Among Novice, Non-Expert, and Expert Volleyball Players: A Microanalytic Study. *Journal of Applied Sport Psychology*, 14(2), 91-105. doi: 10.1080/10413200252907761.
- [10] Kreklow, W. (2015). Training Setters. In C. Reynaud (Ed.), *The Volleyball Coaching Bible, Volume II* (pp. 151-162). Champaign: Human Kinetics.
- [11] Loehr, J.E. (1991). *Mental Toughness Training for Sports: Achieving Athletic Excellence*. New York City: Plume.
- [12] Milavić, B., Jurko, D., & Grgantov, Z. (2013). Relations of Competitive State Anxiety and Efficacy of Young Volleyball Players. *Collegium antropologicum*, 37(2), 83-92.
- [13] Mohammadzadeh, H., & Sami, S. (2014). Psychological Skills of Elite and Non-Elite Volleyball Players. *Annals of Applied Sport Science*, 2(1), 31-36. Retrieved from <http://aassjournal.com>.



- 
- [14] Parnell, A. (2015). *The Psychology of Individual and Team Sports*. Retrieved from <http://sportsnscience.utah.edu/2014/05/11/team-psychology-basic>.
- [15] Perasović, B., & Bartoluci, S. (2007). Sociologija sport u hrvatskom kontekstu. *Sociologija i prostor*, 45(1), 105-119.
- [16] Raglin, J.S., & Morris, M.J. (1994). Precompetition anxiety in women volleyball players: a test of ZOF theory in a team sport. *Br J Sports Med*, 28, 47-51. doi: 10.1136/bjism.28.1.47.
- [17] Sparkes, A. C., & Smith, B. (2014). *Qualitative Research Methods in Sport, Exercise and Health*. London, New York: Routledge.

### Author Info

Corresponding author: [tgutovic@gmail.com](mailto:tgutovic@gmail.com); [teagut@kifst.hr](mailto:teagut@kifst.hr)

## **Spirometric Evaluation In Sitting Volley: A Pilot Study**

Alessandra Tiloca PhD<sup>1</sup>, Mafalda Orlando<sup>2</sup>, Giovanni Monteleone<sup>3</sup>

*PhD student, University of Split, Faculty of Kinesiology<sup>1</sup>*

*ASL Rome 1 Pneumology Outpatient Clinic<sup>2</sup>*

*Bachelor Degree in Motor Science at Tor Vergata University Rome<sup>3</sup>*

### **Abstract**

#### **Introduction**

**S**itting Volleyball is a recently introduced team sport suitable for people with lower limb disabilities, but it can also be played by no-disable people because it doesn't require any aids (is. wheelchair).

Sports practice is able to adapt respiratory mechanics in relation to the type of motor demand of each specific sports discipline: Sitting Volleyball respiratory adaptation is not known.

This study compares disable with no-disable athletes and aims to evaluate the effect of the sitting volley practice on respiratory function, regardless of the presence of motor disability.

#### **Materials and methods**

Simple spirometric exam evaluated respiratory function of 16 athletes, including 9 disable and 7 no-disable, (7 women and 9 men), aged between 17 to 68, regularly trained for 6 months.

The ventilation parameters considered were: forced vital capacity (FVC), volume exhaled in 1 second (FEV1), inspiratory capacity (IC), slow vital inspiratory capacity (ICV), expiratory flow peak (PEF), mean flow from 25 To 75% of the FVC (25-75% FEF). The data collected in an Excel database were statistically analyzed.

#### **Results**

There was no statistically significant difference in ventilatory function of agonist players compared to amateur players. Specific disabilities (e.g. medullary injury - amputation) showed differences in ventilatory capacity values.

### **Conclusions**

*Sitting volleyball produces beneficial effects favoring aggregation and social integration: the trainer needs to have a thorough understanding of the effects of different disabilities on respiratory function to avoid athletes' cardio-respiratory stress.*

**Keywords:** *spirometric, disable, respiratory, sitting-volleyball*

### **Author Info**

*Corresponding author: [altilok@yahoo.it](mailto:altilok@yahoo.it)*

## Effects of kinesiotherapy after conservative treatment of distal radius fracture: Home-based vs supervised physical therapy protocol

Maki Grle<sup>1</sup>, Goran Vrgoč<sup>2,3</sup>, Branka Matković<sup>3</sup>,  
Ivana Grle<sup>4</sup>, Goran Jelaska<sup>5</sup>, Goran Sporiš<sup>3</sup>

<sup>1</sup>Department of Orthopedic Surgery, University Clinical Hospital Mostar, Mostar, Bosnia and Herzegovina

<sup>2</sup>Department of Orthopedic Surgery, University Hospital "Sveti Duh", Zagreb, Croatia

<sup>3</sup>Faculty of Kinesiology, University of Zagreb, Zagreb, Croatia

<sup>4</sup>Department of Physical Medicine and Rehabilitation, University Clinical Hospital Mostar, Mostar, Bosnia and Herzegovina

<sup>5</sup>Department of General Surgery, Virovitica County Hospital, Virovitica, Croatia

### Abstract

*Principal objective of this study was kinesiotherapy importance assessment after conservative treatment of fractures of the distal part of radius. The study included comparison of home-based exercises with supervised kinesiotherapy protocol to examine which would give better results in restoring normal function of the hand. The study included 40 patients, aged between 37 and 85. A total of 29 patients reported injuries in their left hand and 11 patients complained about their right hand, 16 patients had intra-articular distal radius fractures while 24 patients had extra-articular distal radius fractures. Radiological confirmation of fracture reposition was followed by immobilization with forearm plaster splint and with wrist in mild palmar flexion and ulnar deviation. Four weeks later, the immobilization was discharged and patients were divided into two groups: Group 1- home kinesiotherapeutical programme (HK) and Group 2- control group including patients who attended on a supervised physical therapy (SK). After the removal of the immobilization in all patients from both groups, range of motion (ROM) testing was done and all patients completed the questionnaire Patient-Rated Wrist Evaluation (PRWE) and underwent radiographic measurements. Due*

to identification of significance of differences between groups and within repeated measurements 2-way mixed design ANOVA was applied. From the perspective of the overall sample, the patients had significantly higher PRWE before rehabilitation in relation to the time period after rehabilitation ( $F[1.38]=202.931, P<0.001$ ). Mean PRWE for HK group, taking the average of the two measurements was  $48.442\pm 3.527$  points, and thus it was not significantly lower than in SK group ( $57.982\pm 4.806$  points) ( $F[1.38]=2.561, P=0.118$ ). No difference was registered in ROM between the two groups, while ROM was significantly improved in both groups after the period of rehabilitation. The same results were obtained for radiological parameters as well. Results of this study show there was no significant difference between clinical and radiological parameters among the patients from both groups. Results are clearly pointing to the fact that HK is the cost-effective method of choice in the rehabilitation of patients after conservative treatment of distal radius fractures which provides results equal to standard physical treatment.

**Keywords:** ROM, Patient-Rated Wrist Evaluation, radiographic measurements, 2 way ANOVA

## References

Egol, K. A., M. Walsh, S. Romo-Cardoso, S. Dorsky and N. Paksima. "Distal Radial Fractures in the Elderly: Operative Compared with Nonoperative Treatment.", *J Bone Joint Surg Am* 92, no. 9 (2010), pp. 1851-7.

Goldfarb, C. A., Y. Yin, L. A. Gilula, A. J. Fisher and M. I. Boyer. "Wrist Fractures: What the Clinician Wants to Know.", *Radiology* 219, no. 1 (2001), pp. 11-28.

Handoll, H. H., R. Madhok and T. E. Howe. "Rehabilitation for Distal Radial Fractures in Adults.", *Cochrane Database Syst Rev*, no. 3 (2006): CD003324.

Vasenius, J. "Operative Treatment of Distal Radius Fractures.", *Scand J Surg* 97, no. 4 (2008), pp. 290-6; discussion 296-7.

## Author Info

Corresponding & presenting author: Goran Jelaska, MD, [goran.j1973@gmail.com](mailto:goran.j1973@gmail.com)

## Body Mass Index of athletes participating in football premier league in Montenegro

Dusko Bjelica, Jovan Gardasevic, Ivan Vasiljevic, Stevo Popovic

University of Montenegro, Faculty for Sport and Physical Education, Niksic, Montenegro

### Abstract

**Introduction:** It is well-known that physical activity across the lifespan is an important factor of improving human health (Popovic and Bjelica, 2016); however, contemporary sport trainings are designed to improve the performance of high level athletes. Among performing optimum capacity in terms of biomechanics and physiology, all athletes need specific anthropometric characteristics to achieve maximum performance (Popovic and Bjelica, 2015). Hence, the purpose of this study was to describe body height, body weight and body mass index of Montenegrin football players participated in football premier league and to detect possible differences in relation to sedentary subjects from the same country.

**Methods:** Seventy-one males were enrolled in the study. They were divided into two groups: fifty football players (FC Buducnost, FC Sutjeska, and FC Mladost) participated in football premier league of Montenegro ( $22.84 \pm 4.47$  yrs.) and twenty-one healthy sedentary subjects from the same country ( $20.94 \pm 3.10$  yrs.). All subjects were assessed for the anthropometric measures, using the standardized procedure recommended by the International Biological Program (IBP) standards. Height and weight was measured to the nearest 0.1 cm. Body mass index (BMI) was calculated as body mass in kilograms divided by height in meters squared ( $\text{kg}/\text{m}^2$ ). The descriptive statistics were expressed as a mean (SD) for each variable. Independent-samples T test was carried out to detect the effects of football sport on each variable: body height, body weight and body mass index (BMI).

**Main Results:** The mean of the body height was  $182.58 \pm 6.19$  centimeters for football players and  $184.14 \pm 0.07$  for non-athletes, body weight was  $78.45 \pm 7.61$  (athletes) and  $82.66 \pm 14.11$  (non-athletes) and BMI was  $23.45 \pm 1.33$  (athletes) and  $24.34 \pm 3.71$  (non-athletes). A significant difference was not found for all variables: body height ( $p=0.33$ ), body weight ( $p=0.08$ ) and body mass index ( $p=0.09$ ).

**Conclusion:** *The results of this study revealed that although most of the sedentary subjects are not regularly trained; they didn't show significant differences in all tested parameters. Hence, these findings suggest us to conclude that sedentary boys in Montenegro have great body composition assessment and they are not obese. On the other hand, they are a bit taller and heavier, comparing to football players, but not significantly. This might be caused by selection of young people for this sport.*

**References:** *Popović, S., & Bjelica, D. (2016). Body Mass Index of Montenegrin athletes participating in water polo at the London 2012 Summer Olympics. In Conference Abstract Book of the 7th Conference of HEPA Europe "Walking the Walk" (69), Belfast: HEPA Europe; Popovic, S., & Bjelica, D. (2015). Effect of Water Polo Sport on Body Mass Index in Highly Trained Junior Players. In Conference Abstract Book of the 6th Conference of HEPA Europe "Promoting Active Living: The Collaborative Perspective" (68), Istanbul: HEPA Europe.*

**Keywords:** *We would like to encourage you to list your keywords in this section*

### Author Info

Corresponding author: [stevop@ac.me](mailto:stevop@ac.me)

## Effects of carbohydrate supplementation in combination with resistance training on morphological characteristics

Mila Vukadinović Jurišić, Dušan Rakonjac, Jelena Obradović

Faculty of Sport and Physical Education, University in Novi Sad

### Abstract

*The purpose of this study was to determine the effects of carbohydrate supplementation during eight weeks of resistance training on morphological characteristics in young adult men. Fourteen young adult men (age  $22.07 \pm 1.23$  years; body height:  $181.48 \pm 2.54$  cm; body weight  $79.04 \pm 6.63$  kg) were divided into two groups: an experimental group (E;  $n=9$ ) and a control group (K;  $n=5$ ). Participants in the experimental group ingested carbohydrate supplements during 8 weeks of resistance training (30g during the training session, 30g immediately after the training session) while participants in control group did not use carbohydrates or other nutritional supplements, but only trained 8 weeks of resistance training. Morphological characteristics (anthropometric parameters and body composition) were measured before and after the training program. Data was analyzed with a Two-way Mixed design Anova ( $\leq 0.05$ ). The results showed that E group had a significant greater increase in chest circumference (4.47% and 1.22%), biceps girth (7.77% and 3.34%), muscle mass (9.03% and 4.03%) than K group. In addition, E group experienced significant greater decrease of fat mass (-9.11% and -5%) than K group. We concluded that eight weeks of resistance training with 30g of carbohydrate supplements ingested during training session and 30g immediately after a training session is more effective than just resistance training for improving the morphological characteristics of young adult men.*

**Keywords:** anthropometric assessment, body composition, strength training, nutrition supplement



## 1. Introduction

Resistance training has been shown to improve most health- and skill-related components of physical fitness [1]. It is characterized by short bursts of nearly maximal muscular contractions, while glycogen has a relatively important role for energy metabolism during resistance exercise [2]. Muscle glycogen during resistance training is reduced approximately 24-40% [3], which contributes to the reduction of performance [4]. To prevent the reduction of muscle glycogen and performance, athletes often use carbohydrate supplementation.

Carbohydrate supplementation is an ergogenic aid which may attenuate loss of muscle glycogen associated with resistance training [5] and therefore influences the reduction of performance. Consumed carbohydrate supplementation before and after resistance training prevents decrease in performance and enhances muscle glycogen concentrations [6]. Furthermore, it promotes efficient recovery between bouts and increases the amount of total work [7]. Authors [7] suggest that carbohydrate supplementation during resistance training can maintain muscle glycogen stores. Supplementing with carbohydrates before, during and after resistance training has been shown to have a positive effect on athlete's performance, but there is still limited research investigating carbohydrate supplementation during strength and conditioning exercises [8]. Certain studies investigate the effects of carbohydrate supplementation (20g dextrose ingested 1h before and 20g dextrose ingested after resistance training) during 10 weeks of resistance training in young male adults, and the results showed an increase in fat-free mass and a decrease of fat mass [9]. However, supplementing with carbohydrates (30 g maltodextrin) during 12 weeks of resistance training increased muscle mass, but did not decrease fat mass [10]. We can observe that consuming carbohydrate supplements before and immediately after resistance exercise may improve body composition to a certain extent, but the question is whether it affects anthropometric parameters.

In scientific literature, there is a small number of studies investigating the effects of carbohydrate supplementation on anthropometric parameters. Therefore, the purpose of this study was to determine the effects of an 8-week resistance training program combined with the ingestion of carbohydrate supplements (30g before and 30g immediately after resistance training) in comparison to resistance training on morphological characteristics.

## 2. Materials and methods

### *Participants*

Fourteen young adult men participated in this study. Baseline physical characteristics are presented by the group in Table 1. Participants were all second year students of the Faculty of Sport and Physical Education, University of Novi Sad, and they were healthy and informed about the study design. Participants were not permitted to use any additional nutritional supplementation and had not consumed anabolic steroids or any other anabolic agents known to increase performance over the course of the previous years.

Participants were randomly assigned in two groups. The experimental group (E; n=9) consumed carbohydrate supplement Vitargo® Scitec Nutrition (30g during the training session and 30g immediately after the training session) during 8 weeks of resistance training. To compare the effects of supplementation with no supplementation, 5 participants were allocated to a control group (K; n=5). Participants in the control group only applied resistance training, without supplementation. All groups performed the same resistance training for 4 days per weeks via a split routine program for 8 weeks (see Table 2)

**Table 1.** Baseline physical characteristics. Data is presented as the mean ( $\pm$ SD)

	E (n=9)	K (n=5)
Age (years)	22.05 $\pm$ 1.02	22.09 $\pm$ 1.45
Body mass (kg)	79.23 $\pm$ 9.22	78.85 $\pm$ 4.05
Body height (cm)	182.15 $\pm$ 2.45	180.82 $\pm$ 2.64

None of the group differences were significant. E - Consumed carbohydrates during 8 weeks of resistance training; K - 8 weeks of resistance training

### *Measurements*

Participants were measured in the laboratory before and after the training program. Body height (BH) was measured to the nearest 0.1 cm using a Martin anthropometer, while body mass (BW) was measured to the nearest 0.1 kg with a standard scale utilizing a portable balance. Skinfolds (mm) were measured at two sites: triceps skinfold thickness and abdominal skinfold thickness (using a skinfold caliper). The circumferences were measured by measuring cape (cm): chest circumference, thigh circumference, abdominal circumference and biceps girth. Body composition: fat-free mass (kg), fat mass (kg) and muscle

mass (kg) were measured on the basis of a bioimpedance method using Maltron BioScan 920-2.

### *Training Procedure*

Participants trained for 12 weeks (four sessions per week). All participants underwent a familiarization period before starting the resistance training protocol (Figure 1).

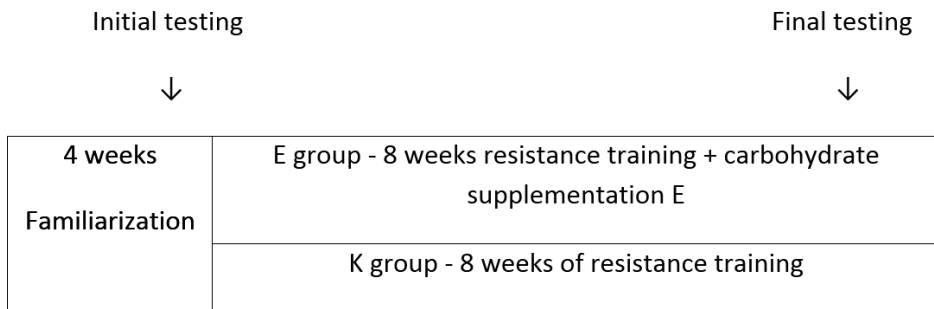

**Figure 1.** The training procedure

The first phase of the training procedure was a four-week preparatory resistance training period, during which subjects were familiarized with resistance training. Over the course of this resistance training period, subjects held whole body workouts four times per week. The subjects used approximately ten exercises in one workout, 2 - 3 sets of every exercise, with 10-12 repetition in every set. Recovery time between the sets lasted two minutes. Training loads were 60-80% of one repetition maximum (1RM) increasing throughout the preparatory phase. The purpose of this familiarization period was to prepare participants for resistance training and improve improper techniques.

After familiarization, participants were involved in an eight-week resistance (four times per week) training protocol. Table 2 lists the main details of the resistance training. There were three different training sessions, the fourth training session was the same as the first, the fifth as the second, the sixth as the third, the seventh as the first etc. The training techniques were carefully supervised and the training was controlled throughout the whole resistance training.

**Table 2.** Eight-week resistance training program (Maksimović et al., 2016)

<b>First training session</b>	<b>Primary exercises</b>	<b>Number series</b>	<b>Load</b>	<b>Secondary exercises</b>	<b>Number series</b>	<b>Load</b>
Chest	Bench press	4	80%1RM 90%1RM 95%1RM 80%1RM	Incline dumbbell flies  Pull over	3	80%1RM 90%1RM 95%1RM
Biceps	Scott bench biceps curls	4	80%1RM 90%1RM 95%1RM 80%1RM	Seated dumbbell biceps curls  Single-arm preacher curls	3	80%1RM 90%1RM 95%1RM
<b>Second training session</b>						
Back	Pull-ups	4	80%1RM 90%1RM 95%1RM 80%1RM	Deadlift  Seated row	3	80%1RM 90%1RM 95%1RM
Triceps	Barbell lying triceps extensions	4	80%1RM 90%1RM 95%1RM 80%1RM	Triceps push-downs  One-arm triceps dumbbell extensions	3	80%1RM 90%1RM 95%1RM
<b>Third training session</b>						
Shoulder	Seated barbell shoulder press	4	80%1RM 90%1RM 95%1RM 80%1RM	High pull  Dumbbell shoulder press	3	80%1RM 90%1RM 95%1RM
Legs	Squat	4	80%1RM 90%1RM 95%1RM 80%1RM	Leg curls  Dumbbell lunge	3	80%1RM 90%1RM 95%1RM

### Supplementation

During the familiarization period (4 weeks), participants (n=14) did not consume supplements at all. After the period of familiarization ended, participants in E group (n=9) consumed 30g (502.4 kcal) Vitargo® Scitec Nutrition during and 30 g (502.4kcal) Vitargo® Scitec Nutrition immediately after resistance training for 4 days per week over the course of 8 weeks. One spoonful or 30g (502.4 kcal) of carbohydrates with molecular weight from barley starch. Furthermore, participants in K group (n=5) did not use carbohydrates or other nutritional supplements, they only trained 8 weeks of resistance training. During the training program participants maintained their habitual daily diet (Table 3).

### Statistical analysis

All subjects who completed the study were included in the data analysis. Statistical analysis was conducted using SPSS 20 for Windows (v20.0., SPSS, Inc., Chicago, IL, USA). Measures were compared by a two-way mixed model ANOVA with repeated measures to establish if any significant differences existed between participants responses over time (initial and final measurement), with groups (E or K) included as a between-subjects factor. The significance level was set at  $p \leq 0.05$ . All results were expressed as mean  $\pm$  standard deviation (SD).

## 3. Results and discussion

Of the original 15 participants who volunteered, 14 completed the study. One subject from E group withdrew because of personal reasons. There were no differences between the E and K group for any of the initial measurements (Table 4). Dietary intake did not differ significantly between groups (Table 3).

**Table 3.** Daily macronutrient intakes of E and K groups before and after 8 weeks of resistance training and supplementation. Data is presented as the mean ( $\pm$ SD)

Groups	Carbohydrate (Kcal)	Carbohydrate% (g/day)	Protein % (g/day)	Fat % (g/day)
E	2858.00 $\pm$ 211.03	58.67 $\pm$ 8.43	23.99 $\pm$ 2.22	17.22 $\pm$ 6.61
K	2843.40 $\pm$ 239.01	58.07 $\pm$ 3.98	24.38 $\pm$ 0.71	16.48 $\pm$ 5.38

\*Average daily macronutrient intakes are based on 7-day food records collected the week prior to training and supplementation and over the course of 8 weeks. No significant differences in macronutrient intake were observed between E and K groups throughout the course of the study ( $p > 0.05$ ).

To our knowledge, this is the first study to compare the effect of carbohydrate supplementation combined with resistance training and resistance training only on anthropometric parameters in young adult men. In the current study, results showed that E group significantly increased biceps girth (+7.77%) compared to K group (+3.34%). These results are in agreement with the authors results [11] which show a significant increase in biceps girth in 38 healthy volunteers aged 18-32 years after 7 weeks resistance training. Also, after 8 weeks of resistance training, chest circumference was significantly greater in E group (+4.47%) compared to K group (+1.22%), with no other differences between groups. Enhancement of chest circumference in E group may be the result of consumed carbohydrates during and immediately after resistance training. On the basis of observations of resistance training alone, it can be concluded that 7 weeks of resistance training improved upper arm circumference [11]. However, consumed carbohydrate supplementation during or immediately after resistance training greatly increased chest circumference in comparison to resistance training alone. Consumed carbohydrate supplements increased upper-body repetitions [12]. Other studies also indicate that consumed carbohydrate supplements prior to and during resistance training increased the number of sets (+2.7) and repetitions (+20) [13]. thus, potentially enhancing the physiological adaptations that are associated with resistance training [5].

**Table 4.** Results in anthropometric parameters at the initial and final measurement. Data is presented as the mean ( $\pm$ SD)

Variable	Groups	Initial	Final
Body mass (kg)	E	79.23 $\pm$ 9.22	80.39 $\pm$ 8.12*
	K	78.85 $\pm$ 4.05	79.42 $\pm$ 4.43*
Chest circumference (cm)	E	97.16 $\pm$ 4.91	101.50 $\pm$ 5.90 †*
	K	93.70 $\pm$ 2.01	94.84 $\pm$ 2.36*
Abdominal circumference (cm)	E	84.72 $\pm$ 6.51	84.27 $\pm$ 5.58
	K	88.44 $\pm$ 2.64	86.80 $\pm$ 1.39
Thigh circumference (cm)	E	57.55 $\pm$ 3.97	59.38 $\pm$ 4.06*
	K	55.70 $\pm$ 0.44	56.70 $\pm$ 0.44*
Biceps girth (flexed 90° and tensed) (cm)	E	34.38 $\pm$ 1.59	37.05 $\pm$ 2.54 †*
	K	34.10 $\pm$ 0.89	35.24 $\pm$ 1.27*
Abdominal skinfold (mm)	E	11.97 $\pm$ 4.81	11.30 $\pm$ 3.26
	K	11.05 $\pm$ 1.13	10.09 $\pm$ 0.74
Triceps skinfold (mm)	E	8.46 $\pm$ 1.92	7.47 $\pm$ 1.47*
	K	8.60 $\pm$ 0.61	7.92 $\pm$ 0.86*

Note E - consumed carbohydrates during 8 weeks resistance training; K - 8 weeks of resistance training

\* Significantly greater improvement from baseline ( $p \leq 0.05$ ).

† Significantly greater improvements than in the control group ( $p \leq 0.05$ )

There was a significant group x time interaction for fat mass and muscle mass ( $p \leq 0.05$ ). Resistance training without any supplementation can provide benefits to body composition such as improved muscle mass and decreased fat mass [14]. After 8 weeks of resistance training, fat mass was significantly decreased in E group (-9.11%) compared to K (-5%). Contrary results can be noted in the study [12] where consumed carbohydrate supplementation during 8 weeks resistance training did not affect the reduction of fat mass in sixteen resistance trained men ( $24 \pm 1.6$  years). One possible explanation for the result is in the training experience of respondents. Most of the nutrition studies and this study were conducted on previously untrained subjects, which is problematic as the stressors related to unaccustomed exercise may differ. Muscle mass was significantly greater after 8 weeks of training in E group (+9.03%) compared to K group (+4.03%). Resistance training causes an increase in protein synthesis and protein breakdown, but in post absorptive state still remains negative. On the other side, ingestion of carbohydrates during and immediately after resistance exercise has been shown to increase post exercise insulin and growth of hormone levels, which may lead to increased protein synthesis and hypertrophy [15]. After 8 weeks of resistance training, E and K groups increased fat-free mass, but significant differences between the groups were not observed ( $p > 0.05$ ).

**Table 5.** Results of body compositions at initial and final measurement.  
Data is presented as the mean ( $\pm$ SD)

Variable	Groups	Initial	Final
Fat-free mass (kg)	E	68.89 $\pm$ 5.79	71.96 $\pm$ 5.26*
	K	68.62 $\pm$ 2.09	70.58 $\pm$ 2.09*
Fat mass (kg)	E	8.89 $\pm$ 0.85	8.08 $\pm$ 0.98*+
	K	8.30 $\pm$ 0.44	7.90 $\pm$ 0.44*
Muscle mass (kg)	E	32.13 $\pm$ 1.69	35.03 $\pm$ 1.39*+
	K	31.98 $\pm$ 0.59	33.27 $\pm$ 0.88*

Note E - consumed carbohydrates during 8 weeks resistance training; K - trained 8 weeks resistance training;

\*Significantly greater improvement from baseline ( $p \leq 0.05$ ).

## 4. Conclusions

Carbohydrate supplementation combined with 8 weeks of resistance training had more beneficial effects on morphological characteristics than resistance training alone in young adult men. 30 g of consumed carbohydrate supplements during and 30 g immediately after resistance training achieved greater gains in chest circumference, biceps girth, fat mass and muscle mass than resistance training alone in regard to young healthy adolescent men. Future research with a larger sample size and a longer training period should assess translational efficiency to determine the mechanism of any ergogenic response from carbohydrates.

## 5. References

- [1] W. J. Kreamer and N. A. Ratamess, "Fundamentals of resistance training: progression and exercise prescription", *Medicine and science in sports and exercise*. vol. 36, no. 4., (2004), pp. 674-688.
- [2] P. Knuiman, M. T. Hopman and M. Mensink, "Glycogen availability and skeletal muscle adaptations with endurance and resistance exercise", *Nutrition & metabolism*. vol. 12, no.1, (2015), pp. 59.
- [3] R. Koopman, R. Manders, R. Jonkers, H. Kuipers and L. Van Loo, "Intramyocellular lipid and glycogen content are reduced following resistance exercise in untrained healthy males", *European Journal of Applied Physiology*. vol. 96, no. 5, (2006), pp. 525-534.
- [4] J. S. Volek, M. J. Sharman, D. M. Love, N. G. Avery, T. P. Scheett and W. J. Kreamer, "Body composition and hormonal responses to a carbohydrate-restricted diet", *Metabolism*. vol. 51, no. 7, (2002), pp. 864-870.
- [5] G. G. Haff, M. J. Lehmkuhl, L. B. McCoy and M. H. Stone, "Carbohydrate supplementation and resistance training", *The Journal of Strength & Conditioning Research*. vol. 17, no. 1, (2003), pp. 187-196.
- [6] P. J. Cribb and Hayes, A, "Effects of supplement-timing and resistance exercise on skeletal muscle hypertrophy", *Medicine & Science in Sports & Exercise*. vol. 38, no. 11, (2006), pp. 1918-1925.
- [7] G. G. Haff, A. J. Koch and K. E. Kuphal, "The effects of supplemental carbohydrate ingestion on intermittent isokinetic leg exercise", *Journal of sports medicine and physical fitness*. vol. 41, no. 2, (2001), pp. 216-222.



- [8] B. M. Krings, J. A. Routree, M. J. McAllister, P. M. Cummings, T. J. Peterson, B. J. Fountain and J. W. Smith, "Effects of acute carbohydrate ingestion on anaerobic exercise performance", *Journal of the International Society of Sports Nutrition*. vol. 13, no. 1, (2016), pp. 40.
- [9] D. S. Willoughby, J. R. Stout and C. D. Wilborn, "Effects of resistance training and protein plus amino acid supplementation on muscle anabolism, mass, and strength", *Amino acids*. vol. 32, no. 4, (2007), pp. 467-477.
- [10] J. J. Hulmi, M. Laakso, A. A. Mero, K. Hakkinen, J. P. Ahtiainen and H. Peltonen, "The effects of whey protein or without carbohydrates on resistance training adaptations", *Journal of the International Society of Sports Nutrition*. vol. 12, no. 1, (2015), pp. 48.
- [11] T. Weiss, J. Kreitingner, H. Wilde, C. Wiora, M. Steege, L. Dalleck and J. Janot "Effect of functional resistance training on muscular fitness outcomes in young adults", *Journal of Exercise Science & Fitness*. vol. 8, no. 2, (2010), pp. 113-122.
- [12] W. D. Dudgeon, E. P. Kelley and T. P. Scheett, "Effect of whey protein in conjunction with a caloric-restricted diet and resistance training", *The Journal of Strength & Conditioning Research*. vol. 31, no. 5, (2017), pp. 1353-1361.
- [13] C. P. Lambert, M. G. Flynn, J. B. Boone, T. J. Michaud and J. Rodriguez-Zayas, "Effects of carbohydrate feeding on multiple-bout resistance exercise", *The Journal of Strength & Conditioning Research*, vol. 5, no. 4, (1991), pp. 192-197.
- [14] W. L. Westcott, "Resistance training is medicine: effects of strength training on health", *Current Sports Medicine Reports*, vol. 11, no. 4, (2012), pp. 209-216.
- [15] M. S. Conley and M. H. Stone, "Carbohydrate ingestion/supplementation for resistance exercise and training", *Sports Medicine*, vol. 21, no. 1, (1996), pp.7-17.

### Author Info

*Mila Vukadinović Jurišić*

[mila.vukadinovic88@gmail.com](mailto:mila.vukadinovic88@gmail.com)

## Impact of uniform repeated exercise on white blood cells count

Antoniĳo Đerek, Boris Dugonjić

Faculty of Kinesiology University of Split

### Abstract

#### Introduction

White blood cells are part of immune system that fights various types of pathogens. In accordance with many authors high intensity exercise regularly increases the number of white blood cells especially monocytes, neutrophils and lymphocytes. Studies made with endurance athletes reported post-exercise decrease of white blood cells with a focus on neutrophils and monocytes. Very little is known about exercise effect on white blood cells count among sportsmen that are involved in sport activity that requires same form of exercise for a long period of time. The aim of the study was to adjust whether the repeated exercise of the same form influence on white blood cells count.

#### Methods

Twenty seven professional football players (age:  $21.85 \pm 2.85$ , height:  $183.69 \pm 5.99$  cm, weight:  $75.81 \pm 6.21$  kg) participated in a three week training period. **High intensity, block training for lower extremities was performed. First block was focused on enhancement of muscular strength, second block intention was to improve aerobic power, and the aim of third block was the improvement of sprint repetition ability and fatigue tolerance.** Blood samples were taken 24 hours after training period. Venous blood samples were drawn from cephalic vein. Total plasma leukocytes, monocytes, neutrophils, lymphocytes, basophils, and eosinophil were measured.

#### Results

After three weeks training period white blood cells count decreased, with the exception of basophiles ( $0.07 \pm 0.02$  G/L; min= 0.04 G/L, max= 0.14 G/L; referent

value: 0.00 – 0.06 G/L) whose number has increased. T-test of single means against referent constant was performed. It showed significant difference between measured basophils and referent value means (**0.07 ± 0.02 vs. 0.03; p= 0.000**).

### Conclusion

Certain types of exercise that demands repetition of the same movement can distract normal blood flow and focus it in the activated muscles leaving remaining cell tissues in a deficient of white blood cells, nutrients and oxygen. Repeated high intensity exercise could have the same, decreasing effect on white blood cells like prolonged exercise. Increased number of basophils can suggest the body adaptation on peripheral hypoxia by basophil histamine release, causing vasodilatation as a respond on oxygen deficit. Active recovery that will engage other muscle groups could normalize blood flow and reduce possible exercise induced hypoxia.

### References

E. I. Obeague, G. U. Obeague, E. Odo (2016) A Review on exercise and blood cells. *Int. J. Adv. Multidiscip. Res.* 3(11): 70- 75.

P. Mucci, F. Durand, B. Lebel, J. Bousquet, C. Prefaut (2001) Basophils and exercise- induced hypoxemia inn extreme athletes. *J. of Ap. Physiol.* Vol.90.no 3, 989-996.

S. Ali, F. Ullah, R. Jan (2003) Effects of intensity and duration of exercise on differential leucocyte count *J Ayub. Med Coll. Abbottabad.* 15(1): 35- 7.

**Keywords:** White blood cells, basophils, repeated exercise, hypoxia

### Author Info

Antonijo Đerek: antder@kifst.hr

# Injury incidence and severity in elite football players during one competitive season

Duje Radman, Tea Bešlija, Mario Tomljanović

*Faculty of Kinesiology, University of Split*

## Abstract

The aim of the study was to provide info about the occurrence and type of injuries sustained by part of youth and senior players of F.C. Hajduk Split in one competitive football season. The injury data was diagnosed and collected from 116 players total. During the whole season there were 144 injuries sustained by 77 players. The overall injury incidence was 3 injuries per 1000 h of exposure. Most commonly injured body parts were the ankle, knee and groin. Overuse was the main cause of the injuries and muscle and tendon were the most common type of injury among the players. The results of this study suggest the need for injury prevention protocols to reduce the number of overuse injuries in the muscles and tendons in the lower extremities.

**Keywords:** *injury incidence, injury exposure, epidemiology, professional football*

## 1. Introduction

With more than 200 million participants ranging from all age groups and both sexes football is one of the most popular sport in the world. With the increase in popularity, demands of the game are rising from season to season. To be successful football players have to be talented, well trained and healthy, so injuries are major concern in any player's, trainer's or supporter's mind as they can have great impact on performance, finances and wellbeing of the players and clubs. Reducing the injury incidence and injury severity requires a detailed knowledge of epidemiology of football injuries. Previous studies of this matter show methodologic inconsistencies such as that methods of data collection as well as injury definitions considerably varies among authors. The aim of this

study is to provide information about the number and severity of injuries during one training and competitive season among the players of Hajduk Split football academy. It is expected that epidemiological studies of this type, during the larger span of time can provide valuable data and benchmark information, to establish effective evidence based injury prevention programmes.

## 2. Materials and methods

One hundred and sixteen male players ranging from four age divisions were followed over the period from July 2016 to June 2017 in football club Hajduk Split. Players were divided into four categories U14, U16, U18, and Senior B players. Each injury that occurred during that period was diagnosed by the club's official physician and the injury data was recorded by the team's respective strength and conditioning coach. The data recorded for each injury included information about the date of the occurrence, player identification, type of activity, injury description and the number of days player missed the training because of respective injury. This study used the 12 categories of injuries, which have been used in previous studies [10]: foot, ankle, lower leg, knee, thigh, hip/groin, upper extremities, shoulder/clavicle, lumbar/sacrum/pelvis, head/face/neck/cervical, abdomen and sternum/rib/dorsal. Types of injuries were classified into seven categories in accordance with the Consensus Statement for football [5]: fractures and bone stress, joints (non-bone) and ligaments, muscles and tendons, contusions, lacerations and skin lesions, central/peripheral nervous system and other injuries. In addition, injuries were also classified as traumatic (those with an acute onset) or overuse injuries (those without any known trauma). The severity of each injury was defined according to the number of days from the date of injury to the date of the player's return to regular team training or competition. The injury severity was classified into four categories that have been used in previous studies [5, 10]: minimal ( $\leq 3$  days), mild (4–7 days), moderate (8–28 days) and severe ( $> 28$  days). Descriptive statistics are presented as frequencies, proportions (%), incidence rates (per 1000 h of exposure) and 95% confidence intervals. All data was processed using TIBCO Statistica professional for Windows.

## 3. Results and discussion

One hundred and sixteen players were followed over the course of one football season. Players were divided into four age groups: Under (U) 12-14 (N=23), U 14-16 (N=43), U 16-18 (24) and senior B team 18+ (N=26).

Total number of time loss injuries during the preparation and competitive season 2016/17 was 144 sustained by 77 players (66,37 %). The age group U14 sustained 17,36% (N=25) injuries, the age group U16 sustained 21,52% (N=31) injuries, the age group U18 sustained 18,75% (N=27) injuries and the age group 18+ sustained 27,08% (N=39) injuries. The overall injury incidence per 1000h of play was 3,009 (95% CI 2,55 3,54). Most of the injuries were located in lower extremities (78,47%). The most injured body parts were: ankle 18,1% (N=26), knee 15,3% (N=22), groin 12,5% (N=18), anterior thigh 11,8% (N=17), posterior thigh 11,1% (N=16) and lower leg 6,3% (N=9). A total of 49 players (63,63%) sustained 1 injury, 18 players (23,37%) sustained 2 injuries and 10 players (12,98%) sustained 3 or more injuries during the season. The most common diagnosis was lower limb muscle/tendon injury 35,4% (N=51). The majority of the injuries, 32,6% were of moderate severity ranging from 8 to 28 days. 20% of the injuries lasted more than 1 month. Affected body parts, injury types, and injury severities are listed in Tables 1 through 4.

<b>Table 1. Incidence of injuries by location in football academy Hajduk Split</b>					
Location of injury	N	%	Inc.	95% CI	
Head/face	1	0,7%	0,021	0,003	0,148
Neck cervical spine	2	1,4%	0,042	0,011	0,167
Shoulder/clavicle	6	4,2%	0,125	0,056	0,279
Elbow	0	0,0%	0,000	0,000	0,000
Hand/finger/thumb	1	0,7%	0,021	0,003	0,148
Sternum/ribs/back	2	1,4%	0,042	0,011	0,167
Lower back	13	9,0%	0,272	0,158	0,468
Pelvis/hip	6	4,2%	0,125	0,056	0,279
Groin	18	12,5%	0,376	0,237	0,597
Thigh(anterior)	17	11,8%	0,355	0,221	0,571
Thigh(posterior)	16	11,1%	0,334	0,205	0,546
Knee	22	15,3%	0,460	0,303	0,698
Lower leg	9	6,3%	0,188	0,098	0,362
Ankle	26	18,1%	0,543	0,370	0,798
Foot/toe	5	3,5%	0,104	0,044	0,251
	<b>144</b>	<b>100,0%</b>	<b>3,009</b>	<b>2,557</b>	<b>3,543</b>

Note: Results are shown as frequency (N), proportion (%) and incidence (Inc., per 1000h of exposure), CI confidence intervals

**Table 2. Incidence of injuries by type in football academy Hajduk Split**

Location of injury	N	%	Inc.	95% CI	
Muscle and tendon	51	35,4%	1,066	0,810	1,402
Joint and ligament	42	29,2%	0,878	0,649	1,188
Contusions	22	15,3%	0,460	0,303	0,698
Fracture bone stress	17	11,8%	0,355	0,221	0,571
Other	9	6,3%	0,188	0,098	0,362
Nervous sistem	2	1,4%	0,042	0,011	0,167
Lacertation/skin lesions	1	0,7%	0,021	0,003	0,148
	<b>144</b>	<b>100%</b>	<b>3,009</b>	<b>2,557</b>	<b>3,543</b>

Note: Results are shown as frequency (N) , proportion (%) , and incidence (Inc., per 1000h of exposure), CI confidence intervals

**Table 3. Incidence of injuries by nature in football academy Hajduk Split**

Location of injury	N	%	Inc.	95% CI	
Overuse	84	58,3%	1,755	1,418	2,174
Traumatic	60	41,7%	1,253	0,974	1,615
	<b>144</b>	<b>100%</b>	<b>3,009</b>	<b>2,557</b>	<b>3,543</b>

Note: Results are shown as frequency (N) , proportion (%) , and incidence (Inc., per 1000h of exposure), CI confidence intervals

**Table 4. Incidence of injuries by severity in football academy Hajduk Split**

Location of injury	N	%	Inc.	95% CI	
Minimal (1-3)	24	16,7%	0,502	0,336	0,748
Mild (4-7)	43	29,9%	0,899	0,667	1,212
Moderate (8-28)	47	32,6%	0,982	0,738	1,307
Severe (>28)	30	20,8%	0,627	0,438	0,897
	<b>144</b>	<b>100%</b>	<b>3,009</b>	<b>2,557</b>	<b>3,543</b>

Note: Results are shown as frequency (N) , proportion (%) , and incidence (Inc., per 1000h of exposure), CI confidence intervals

We found an overall incidence of 3,0 injuries per 1000 player hours (95% CI 2,55 3,54), which is in congruence with current findings in elite youth and senior football that can vary from 2,0 to 19,4 injuries per 1000h of play [3 ,8, 1, 4 ,9]. According to type, we found results similar to previous studies where the highest incidences of injury were related to muscles and tendons, joints and ligaments, and contusions [3]. According to location results showed the highest incidence of injuries to the lower extremities, particularly the ankle, followed by the knee and groin. These results are not by all means but by most part congruent with other European studies [3, 6, 9]. According to nature of the injury, we showed that overuse injuries were more prevalent (58,3%) than traumatic injuries. Results showed that the most common injuries (32,6%) by severity were moderate 8-28 days, while severe injuries (>28 days) represented 20,6% of the total number of injuries. The current scientific literature on modern football shows simmilar or slightly greater severity of injuries than our study found [3, 9, 7, 2]. Football players from the four professional English leagues showed that 68% of injuries involved more than 8 days out of competition [7]. The strengths of the current study is the analysis using standard definitions of injury, matches, training, location of injury and incidence that will assist in injury data classification within higher incidence groups. The main limitations of this study was the lack of information if the injury occurred during the competition or during the training which could give us a better insight about a degree of occurrence rising with increased playing demands. The other limitation was the estimation of the exposure time which was estimated weekly and based on the mean number of players per team (not at the exact number of players present on the particular event).

#### 4. Conclusions

The main findings of this study indicate that: (1) Senior players are more subservient to injuries than youth players; (2) the top 3 injuries were ankle sprains, knee injuries and groin/inner thigh muscle injuries. (3) Overuse is the main cause. It is well known that difference in training protocols, competition schedule and age can play a major role in determining the injury occurrence in football population. However, there are enough indications (in previous and our study) and a lot of corresponding data where we have evidence and can start to draw conclusions about the most common patterns and types of injuries. Injury incidence in the observed teams in Hajduk Split F.C. is slightly



lower to ones found in other European leagues. Further studies conducted on the larger number of players and during the larger span of time should be done to confirm our data and aid to establish effective prevention protocols for both senior and youth football players.

#### 4. References

[1] Brink, M. S., Visscher, C., Arends, S., Zwerver, J., Post, W. J., & Lemmink, K. A. (2010). Monitoring stress and recovery: new insights for the prevention of injuries and illnesses in elite youth soccer players. *British journal of sports medicine*, 44(11), 809-815.

[2] Drawer, S., & Fuller, C. W. (2002). Evaluating the level of injury in English professional football using a risk based assessment process. *British Journal of Sports Medicine*, 36, 446–451.

[3] Ekstrand, J., Hägglund, M., & Waldén, M. (2011). Epidemiology of muscle injuries in professional football (soccer). *The American journal of sports medicine*, 39(6), 1226-1232.

[4] Ergün, M., Denerel, H. N., Binnet, M. S., & Ertat, K. A. (2013). Injuries in elite youth football players: a prospective three-year study. *Acta Orthop Traumatol Turc*, 47(5), 339-346.

[5] Fuller, C. W., Ekstrand, J., Junge, A., Andersen, T. E., Bahr, R., Dvorak, J., & Meeuwisse, W. H. (2006). Consensus statement on injury definitions and data collection procedures in studies of football (soccer) injuries. *Scandinavian journal of medicine & science in sports*, 16(2), 83-92.

[6] Hägglund, M., Waldén, M., & Ekstrand, J. (2005). Injury incidence and distribution in elite football—a prospective study of the Danish and the Swedish top divisions. *Scandinavian journal of medicine & science in sports*, 15(1), 21-28.

[7] Hawkins, R. D., Hulse, M. A., Wilkinson, C., Hodson, A., & Gibson, M. (2001). The association football medical research programme: an audit of injuries in professional football. *British journal of sports medicine*, 35(1), 43-47.

[8] Junge, A., Chomiak, J., & Dvorak, J. (2000). Incidence of football injuries in youth players. *The American journal of sports medicine*, 28(5\_suppl), 47-50.

[9] Waldén, M., Hägglund, M., & Ekstrand, J. (2005). UEFA Champions League study: a prospective study of injuries in professional football during the 2001–2002 season. *British journal of sports medicine*, 39(8), 542-546.

---

[10] Woods, C., Hawkins, R., Hulse, M., & Hodson, A. (2002). The Football Association Medical Research Programme: an audit of injuries in professional football—analysis of preseason injuries. *British journal of sports medicine*, 36(6), 436-441.

### Author Info

Corresponding author: Duje Radman, [duje.radman@gmail.com](mailto:duje.radman@gmail.com)

## Terrorism in Sports Arena

Mirko Tufegdžija, Ernest Šabić

Panevropski Univerzitet Apeiron Banja Luka

### Abstract

*Threats of terrorist attacks are more frequent under the influence of the general euphoria of nationalism and of structural economical changes. The risk factor for the maintenance of sporting events of international character is a concept of organization, because of the large number of participants, the presence of the media and others. Behind the terrorist activities and acts of violence in sport are appropriate political motives and activities, expressed in extreme nationalist projects, separatist tendencies, extreme ideological currents and radical political movements. In regard the form in which occurs expression of violence and terrorism in the sport they distinguish between the individual and group acts of terror, state terror and international terror. The aim of the paper is to try to explain how sport is at all connected with terrorism and to examine whether there is a possibility that this link is causative, that is, whether the result of sports matches is a predictor of a terrorist attack or that it comes from other initiatives, It's about sports as a mass and social phenomenon. The analytical-descriptive method and content analysis process was used in the research. The basic search was done via the Google Scholar, the Web of Science, the Research Gate search engine in the electronic database, Hrcak. Papers published in available proceedings book from scientific conferences have also been reviewed. Database search was conducted in July 2017 and was based on an analysis of the summaries of published papers containing the following keywords: terrorism, terrorist organizations, sport events, violence, aggression, hooliganism and nationalism. Papers published in Bosnian, Croatian, Serbian and English by July 2017, relating to aggression and violence in sports, are considered and terrorism Papers whose results are presented in quantitative and qualitative manner. In analyzing the content for theoretical elaboration of the research problem, the papers whose contents are based on terrorism in the sport and the aims and aspirations to explain how*

*sport comes into contact with this. The results of the study show that terrorists are “normal people” only in comparison with other people they are more angry and feel some kind of need for outbursts of anger and fury through action. They resort to acts of violence when they see no other option to solve the problem. Data from the police records indicate that terrorists are younger than 25 years of age, higher education, they come from wealthy sections of society, deviate behavior and give in to the use of narcotics. Those who commit acts of political motives most often recognize them but do not assume responsibility for them, but they are attributed to the authorities or the system against which their activity is directed. It can be concluded that it is very important in the prevention of terrorist activities, cooperation at all levels and the strategy of combating terrorism. Organizers and security management must recognize potential threats and security challenges in a timely manner, and in particular they must respect important principles, such as timely and effective planning, communication and training. These would also be key elements of the organization and assurance of general safety at significant major public events such as sports events. Bearing in mind the events in the previous major competitions, the need for increased measures and security measures is imposed, with the engagement of all security structures. Unfortunately, they need to pay more attention to securing sporting events than to the results achieved by athletes.*

**Key Words:** *sport events, violence, aggression, hooliganism, nationalism*

### **Author Info**

mirko.s.tufegdzija@apeiron-edu.eu

ernest\_sabic@yahoo.de

## The Influence of Anthropometry on the Balance Beam Performance of Young Gymnasts

Aleksandra Aleksić-Veljković<sup>1</sup>, Kamenka Živčić Marković<sup>2</sup>, Lucija Milčić<sup>2</sup>,  
Marko Veljković<sup>1</sup>, Marijo Možnik<sup>2</sup>

<sup>1</sup>Faculty of Sport and Physical Education, Niš, Serbia

<sup>2</sup>Faculty of Kinesiology, Zagreb, Croatia

### Abstract

Achieving the best results in Women's Artistic Gymnastics depends on many factors. The balance beam is one of the four apparatus in women's all-around competition, and it is necessary to identify the factors that are crucial in achieving the best results on this apparatus. A review of the literature showed that a small number of studies dealing with this problem, especially in the younger age categories of gymnasts. The main aim of this research is to determine anthropometry as a factor of success in practicing on the balance beam in young categories of gymnasts. The research included 47 gymnasts, participants of the "Laza Krstić and Marica Dželatović" competition held in Novi Sad. Data analysis was performed using SPSS statistical software version 20.0. For each variable the main central and dispersion parameters are shown, and the normality of distribution was tested using the Kolmogorov-Smirnov test. Regression analysis revealed a statistically significant impact of anthropometry on the success. The scientific contribution of this research is to determine the share of selected variables in achieving success on the balance beam in young gymnasts.

**Keywords:** Artistic gymnastics, Regression analysis, Age-group categories

### 1. Introduction

Artistic gymnastics is a polystructural, conventional sport based on complex movements, performed in accordance with aesthetic criteria and strictly defined rules. As one of the basic sports, gymnastics has a significant impact on the transformation of the psychosomatic status of an individual. It

is characterized by the extraordinary richness and complexity of the elements, distributed in structural groups, within the competition disciplines.

In recent years, artistic gymnastics have a great popularity, which is partly attributed to the beginning of training at the earliest age. As in other competitive sports, in gymnastics great attention is paid to methods of identifying talents and achieving top results, too. These methods include the application of various physical, functional and psychological measuring instruments, in order to assess the abilities and characteristics of athletes.

As a basic sport, sports gymnastics affects the development of motor skills: strength, coordination, flexibility and balance [1]. In coordination terms, gymnastic elements are the most complex movements. Testing and periodic monitoring of the ability of young athletes is also important for defining training programs adapted to the requirements of sports and age. In this way, a harmonious development of fundamental motor skills is achieved in accordance with the physical development of the athlete [2]. The specificity of athletes in sports disciplines is the result of selection and, on the other hand, the specific effects of the activities that this discipline creates [3]. In Women's Artistic Gymnastic there are four apparatus (the vault, the uneven bars, the balance beam and the floor).

The balance beam is one of the most attractive apparatus in Women's Artistic Gymnastics. When defining exercises on the balance beam it is often stated that most of the content on this apparatus is taken from the floor, but one should bear in mind the differences in the construction of the device, which also leads to differences in the performance technique. Gymnasts perform exercises on the balance beam, which has a markedly reduced surface of the support of 0,1 meters, a height of 1.25 meters and a length of 5 meters [4]. It is known that gymnasts must have certain specific anthropometric characteristics in order to achieve success in sports gymnastics and this research was aimed at determining the influence of selected variables of anthropometry on success on the balance beam.

## 2. Materials and methods

### *Participants*

The sample of participants consists of 47 female gymnasts, competitors of the International Memorial competition "Laza Krstić and Marica Dželatović",

aged 8 to 12 years. The testing was conducted at the Sokol Society "Vojvodina" in Novi Sad, in cooperation with the Gymnastics Federation of Serbia. The competition was attended by gymnasts from eight European countries: Croatia, Slovenia, Austria, Denmark, Sweden, Romania, Bulgaria, and Serbia.

### Measurements

This investigation covered 14 anthropometric variables, for assessing and defining the morphological status of participants: longitudinal dimension of the skeleton (5 variables), transversal dimensionality of the skeleton (5 variables), body volume and mass (1 variable) and body composition (3 variables).

To obtain variables, the *ImageJ* software was used, which is very precise, objective and easy to apply. This program is used to calculate the length and angles of anatomic and anthropometric measures [3]. For shooting digital photos, a camera (Casio FX) was set up at a distance of 4 meters and the optimum height in relation to the subjects, so that they were taken under the same conditions. Digital calibration of the system was used for the digital photography of an objectively known length (2 meters). Only body height variable (AVIS) and foot diameter (ADST) were measured by the anthropometer.

**Figure 1. The position of the respondents in digital photographs.**

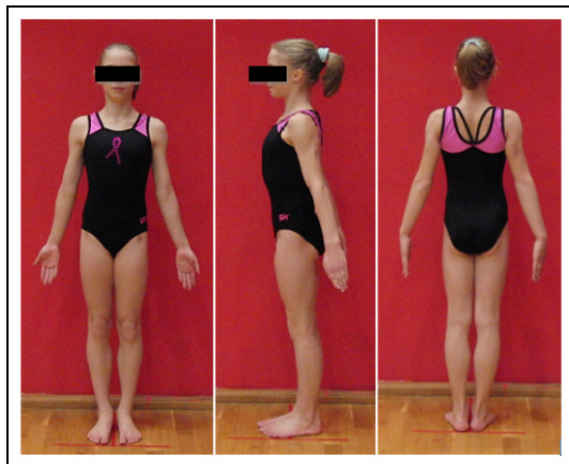

Variables were used to estimate the longitudinal dimension of the skeleton:

1. Body height (AVIS) - measured by anthropometer;

2. Arm length (ADUR) - measured from the top of the shoulder (acromion) to the tip of the stretched middle finger. The hand is spring-loaded and tight;

3. The hand length (ADUS) - measured from the laterar eminence to the tip of the extended middle finger. The fist is spun and taut, with a palm placed on the body;

4. Leg length (ADUN) - vertical distance from the top of the spine iliac anterior superior to the floor. The legs are stretched and tight;

5. Foot-Height Length Index (IDNV) - the relationship between leg length and body height.

To estimate the transversal dimension of the skeleton:

1. Shoulder width (AŠRA) - measured horizontally from the points of maximal provision of m.deltoideus, on the upper, outer side of the arm and shoulder;

2. Right-foot diameter (ADSD) - measured by a shortened anthropometer;

3. Left-foot diameter (ADSL) - measured by a shortened anthropometer;

4. Hips width (AŠKU) - horizontal distance between the maximum projections of the large trochanter major on the femur head (femur).

5. Androgenic index (ANDR) – the ratio between the shoulder and hip width.

Only one variable will be determined for the volume and body weight:

1. Body mass (AMAS) in kg.

For the evaluation of body composition, the digital clinically tested scale Omron BF511 was used. The scale gives a large number of parameters of the body composition, of which were used: Total body fat (0.1%) (AUTM), BMI - Body Mass Index (ABMI) and Basal metabolism (Kcal) (ABAM). All parameters of mass and body composition were obtained by the pressure of the participants on the scale in a vertical position with raised hands in front of the body.

Three variables (Difficulty score - DOCE, Execution score - EOCE and Final score - KOCE) were applied to evaluate the performance on the balance beam, obtained from the official results of the competition.

### *Procedure*

For the needs of the research, in cooperation with the Gymnastics Federation of Serbia, testing was carried out in the small hall. The following optimal conditions for testing are provided:



- Testing was done in the morning hours, before the beginning of the competition;
- The test room was pre-prepared, well lit and with a temperature of 20 to 22°;
- The workplaces and the measurements on each of them were also pre-arranged;
- During the testing, participants were tested in gymnastic leotards and barefoot.

Participants, their trainers, and parents were introduced to the research goal and they signed a consent to participate in the research, in accordance with the Helsinki Declaration on the Rights of the Children. These notifications were sent electronically via gymnastics clubs that participated in the competition.

#### *Statistical analysis*

Data processing was performed using the statistical program SPSS version 20.0. For each parameter, the calculated variables are necessary for analyzing and interpreting the results. Following results were calculated:

1. Arithmetic mean - the mean value of the results obtained within each variable;
2. Standard deviation - as an indication of an absolute deviation of the obtained results from their arithmetic mean;
3. Skewness and Kurtosis asymmetry dimensions - show the significance of the deviation from Gaussian curve (which presents the normality of the distribution of results);
4. Kolmogorov - Smirnov test (K-S test) – normality of distribution of all variables;
5. Regression analysis - for prediction of the impact of anthropometry on the performance on the balance beam based on the competition results.

### **3. Results and discussion**

Table 1 shows the variables of the longitudinal dimension of the participants (body height, arm length, arm length, leg length, foot length, height), transversal dimensionality of the skeleton (hip width, shoulder width, left and right foot diameter), volume and weight of the body (body weight),

assessment of body composition (total body fat, body mass index, basal metabolism) in gymnasts aged 8-12 years. For all variables, the following basic descriptive parameters were calculated: minimum and maximum results (Min, Max.), mean (Mean), standard deviation (SD), a coefficient of asymmetry (Skew.), and a coefficient of curvature (Kurt.).

**Table 1. Descriptive statistics of anthropometry variables (N = 47)**

Var.	Min.	Max.	Mean	SD	Skew.	Kurt.	Z	Sig.
AVIS	119.50	164.00	142.88	10.38	.11	-.66	.73	.66
ADUR	53.60	74.90	63.63	4.96	-.18	-.44	.53	.95
ADUS	12.40	19.10	15.18	1.67	-.09	-.86	.76	.61
ADUN	67.00	92.40	81.58	5.81	-.31	-.06	.46	.99
AINV	49.94	60.69	57.14	1.96	-1.38	3.07	.93	.35
ASKU	20.00	32.70	24.17	2.48	1.11	1.73	1.17	.13
ASRA	25.60	35.00	29.53	2.24	.49	-.37	.99	.29
ANDR	1.07	1.47	1.23	.09	.66	1.03	.96	.31
ADSD	7.20	9.80	8.18	.60	.36	-.19	1.03	.24
ADSL	6.90	9.60	8.03	.62	.08	-.19	.55	.93
AMAS	22.50	62.00	35.59	8.15	.98	.96	1.15	.14
ABMI	14.80	23.10	17.18	1.62	1.29	2.47	.85	.47
AUTM	7.70	21.70	14.42	3.34	.22	-.52	.55	.93
ABAM	1035.00	1424.00	1198.83	85.31	.42	-.14	.78	.58

Legend: Min - minimum score, Max - maximum score, Mean - mean value, SD - standard deviation, Skew. - a coefficient of asymmetry, Kurt. - a coefficient of curvature, z - Kolmogorov-Smirnov Z coefficient; Sig. - level of statistical significance Kolmogorov- Smirnov Z coefficient, AVIS - body height, ADUR - arm length, ADUS - hand length, ADUN - leg length, ASKU - hip width, ASRA - shoulder width, ANDR - androgen index, ADDS - Right Foot Diameter, ADLS - Left Foot Diameter, AMAS - Body Mass, AUTM - Total Body Fat, ABMI - Body Mass Index, ABAM - Basal Metabolism.

The average height of the gymnastics is  $142.88 \pm 10.38$  cm, while the body weight is  $33.59 \pm 8.15$  kg. The lowest gymnast was 119.5 cm high and the highest was 164 cm high. The average body mass index was 17.18. The body mass index serves to assess the state of nutrition. These results indicate a lower body mass index compared to the average population, as gymnastics is an aesthetic sport which requires grace and elegance of gymnasts with a low percentage of fat tissue.

Morphological characteristics are very important for gymnastics because during the performance of the composition there is constant movement of the body from one position to another. Different training techniques and a great deal of repetition of the elements increase the ability to control one's own body during exercises and gymnastics, but morphology is also of great importance. Although there are exceptions, in the earliest selection, the trainers take into account the morphological predispositions of the gymnastics.

The hierarchical analysis of the Soviet author Nabatinkov divided gymnasts abilities into three levels of significance [3]. The first level of the most important abilities and characteristics includes physical characteristics (whole body, body structure, posture, foot structure), functional abilities (mobility, vestibular and visual analyzers) and movement abilities (coordination, agility and relative strength). The second level of additional significance consists of physical characteristics (body proportions and structure), functional abilities (peripheral nervous muscular system, auditory analyzers, endocrine system, cardiovascular system, respiratory system, and metabolism), locomotor abilities (specific endurance, explosive force, speed). The third level of significant abilities and characteristics of gymnastics includes physical characteristics (specific body mass), functional ability (thermoregulation) and locomotor abilities (absolute strength and endurance).

The study of Claessens [5] was aimed at identifying anthropometric variables that correlate with success in gymnastics and the prediction of success by combining anthropometric characteristics. The sample of respondents consisted of competitors of the 24th World Gymnastics Championship in Rotterdam (The Netherlands) in 1987. The research involved 168 gymnasts (ages  $16.5 \pm 1.8$  years old). Very significant correlations ( $p < .01$ ) were determined between skin folds and endomorphism's and gymnastic results. Correlations indicate that gymnasts with a higher percentage of subcutaneous fat tissue have lower results. According to the results from this study, 32% to 45% of the variance in gymnastics can be explained by anthropometric characteristics and additional variables, of which the most important are endomorphism and chronological age. Body height and mass in the senior seniors about 14.5 years is about 153 cm and 44 kg. Gymnasts (the average age of 11.7 years) were the easiest and the shortest athletes who participated in the study together with handball players, tennis players and swimmers [6]. The aim of the study was to determine the profile of the top gymnasts, where it was found that besides the low weight and athletic structure of the gymnastics is characterized by good postural control and balance as well as explosive power.

As mentioned earlier, for gymnasts, the relationship between transversal measures of the skeleton in relation to the whole body is important. Thus, numerous studies show that the shoulder width of the gymnastics is significantly higher in relation to the width of the hips. Androgenic index, the ratio of hip width and shoulder width to young gymnasts is 1.23. The anthropometric dimensions are higher in gymnastics compared to the average population of the same age. In relation to patterns of growth and development, shoulder and hip width increases during childhood and the ratio of acromial and crystalline distance remain constant with a slight increase from 6 to 11 years.

**Table 2. Descriptive statistics of parameters of success on the balance beam**

	N	Min.	Max.	Mean	SD	Skew.	Kurt.	Z	Sig.
<b>DOCE</b>	47	1.00	5.00	3.53	.86	-.20	.05	.80	.54
<b>EOCE</b>	47	1.70	8.50	6.54	1.32	-1.29	2.78	.78	.57
<b>KOCE</b>	47	5.30	13.10	10.07	1.68	-.62	.53	.54	.91

N – a number of respondents, Min - minimum score, Max - maximum score, Mean - mean value, SD - standard deviation, Skew. – a coefficient of asymmetry, Kurt. – a coefficient of curvature, z - Kolmogorov-Smirnov Z coefficient; Sig. - level of statistical significance of Kolmogorov-Smirnov Z coefficients, DOCE – Difficulty score, EOCE – Execution score, KOCE - final score on the balance beam.

The basic central and dispersion parameters and the distribution normality of the three variables for assessing the success on the balance beam are shown in Table 2. All variables have a normal distribution of results.

The increased scoring value for the final score evaluated by the competition (KONO) indicates lower results, while the positive magnified value of the kurtosis indicates the elongation of the curve.

If we compare the results achieved on the balance beam with other competitions, the conclusion is that the results are weaker than at the great gymnastic competitions. In the European Championship 2012 finals in Brussels, the average starting point for juniors (aged 14-15) was  $5.57 \pm 27$  points, while the average E score was  $8.1 \pm 96$  points. The average value and baseline scores and deductions were two points below the European Championship, indicating that the competition was at lower level. However, a sample of 9 to 12-years-olds, competing under international rules, nevertheless shows that they are a representative sample. Table 3 shows the correlation between the criterion variable - the final estimate on the balance beam and the set of predictor variables of anthropometry.

**Table 3. Regression analysis parameters in the latent space of anthropometry and KOSE**

Model	R	R <sup>2</sup>	Adjusted R <sup>2</sup>	Std. Error of the Estimate	F	p
1	.64	.40	.22	1.48	2.15	.04

R - multi-correlation coefficient, R<sup>2</sup> - multi-correlation coefficient, Adjusted R<sup>2</sup>-corrected multi-correlation coefficient, Std. Error of the Estimate.- standard forecast error, F - value of F test that tests the significance of the predictor set to the criterion variable, p - significance level of the multiple correlation coefficient, Predictors: ANDR, AUTM, AINV, ADUR, ASRA, ADUS, ABMI, ADUN, ASKU, AMAS, AVIS

Based on the coefficient of multiple correlations (R), which is equal to .64, a strong relationship between the anthropometry and the final score on the balance beam can be established. According to the value of the multiple correlation squares, which is .403, it can be concluded that the system of predictor variables explains 40.3% of the total variance, while the remainder of 59.7% is under the influence of unexplained factors. The influence of the system of predictor variables statistically significant influence on the criterion variable - the final score of the competition at the level  $p < .05$ . However, no variable contributes statistically significant to this effect (value p, Table 4).

**Table 4. Partial indicators of the regression of the predictor set and criteria – KOSE**

Model		Non-standardized Coefficient		Standardized Coefficient	t	p
		B	Std. Error	Beta		
1	(Constant)	56.59	106.45		.53	.60
	AMAS	-.24	.46	-1.14	-.51	.61
	AVIS	-.27	.70	-1.69	-.39	.70
	ABMI	1.07	1.08	1.03	.99	.33
	AUTM	-.19	.10	-.38	-2.01	.05
	ADUR	.13	.10	.37	1.30	.20
	ADUS	<b>-.34</b>	<b>.22</b>	<b>-.34</b>	<b>-1.51</b>	<b>.14</b>
	ADUN	.58	1.27	1.99	.45	.65
	AINV	-.65	1.87	-.75	-.34	.74
	ASRA	1.61	1.12	2.14	1.43	.16
	ASKU	-1.70	1.37	-2.51	-1.24	.23
	ANDR	-28.12	26.04	-1.45	-1.08	.29

Legend: Predictor's set of anthropometric variables: Dependent variable: KOSE - Final score at the balance beam.

Earlier research was conducted in order to determine the contribution of various morphological characteristics to the level of technical preparation of gymnasts aged 9-12 years [7]. In the first analysis, the influence was found in the variable body height, body weight, body mass index and Rohrer's index (a measure of leanness of a person calculated as a relationship between mass and height), with a total explanation of 45% in the age category of 9 years ( $R^2 = .45$ ,  $r < .01$ ). The value of  $R^2$  was not significant in other age categories (0.15-0.27). In the second analysis, variables were used for the length of the lower extremity, the length of the upper limb, shoulder width, hip width and index of the shoulders and hips. As predictors, these variables explained a significant variation of success in the multiple in boys at age 11 ( $R^2 = 0.59$ ,  $p < .01$ ) and 12 years ( $R^2 = .56$ ,  $p < .01$ ). The values of  $R^2$  (0.24 - 0.38) were not significant for other age categories.

The success of the performance and achievement in various sports is influenced by various variables, such as morphological characteristics, functional characteristics, adaptations to specific training, development of skills and mental skills [7]. The relationship between the morphological characteristics and the effects of training in gymnastics was confirmed. Studies have confirmed that gymnasts are lower in growth and have more athletic structure compared to other athletes [8]. A large number of researches are needed to examine the impact of certain morphological characteristics and the possibility of achieving top results, both in the all-around and on each apparatus. This data contributes to the improvement of gymnastic training and examination of individual predispositions of gymnastics.

#### 4. Conclusions

Women's Artistic Gymnastics is constantly evolving and changing, through changes to the regulations of the International Federation of Gymnastics. Research in the field of gymnastics is necessary in order to improve gymnastic training and success factors in each of the gymnastics apparatus.

This research involved 47 gymnasts aged 8-12 years, competitors at the international competition, with the aim of determining the anthropometry as a factor of success in exercising on the balance beam. The results obtained by this study cannot be generalized to all ages of gymnastics, as 47 gymnasts aged 8-12 years, participated in the research.

## 5. References

- [1] P. Albuquerque and P. Farinatti, "Development and validation of a new system for talent selection in female artistic gymnastics: the PDGO Battery", *Rev. Bras. Med. do Esporte*, vol. 13, (2007), pp. 157–164.
- [2] L. Ricotti, "Static and dynamic balance in young athletes", *Jour. of Human Sport and Exerc.*, vol. 6, no. 4, (2011), pp. 616-628.
- [3] K. Šibanc, M. Kalichová, P. Hedbávný, I. Čuk, and B. Pajek, "Comparison of morphological characteristics of top level male gymnasts between the years of 2000 and 2015", vol. 9, no. 2, (2016), pp. 201–211.
- [4] A. A. Veljković, D. Madić, S. Veličković, K. Herodek, and B. Popović, "Balance in Young Gymnasts : Age-Group Differences", *Phys. Educ. Sport / Wych. Fiz. i Sport*, vol. 12, no. 3, (2014), pp. 289–296.
- [5] L. Claessens, F.M. Veer, V. Stijnen, J. Lefevre, H. Maes, G. Steens, G. Beunen. "Anthropometric characteristics of outstanding male and female gymnasts", *Journal of Sports Sci*, vol. 9, no. 1. (1991), pp. 53–74.
- [6] J. Bencke, R. Damsgaard, A. Saekmose, P. Jørgensen, K. Jørgensen, and K. Klausen, "Anaerobic power and muscle strength characteristics of 11 years old elite and non-elite boys and girls from gymnastics, team handball, tennis, and swimming", *Scand. J. Med. Sci. Sport.*, vol. 12, no. 3, (2002), pp. 171–178.
- [7] A. Kochanowicz, K. Kochanowicz, S. Róžański, D. Wilczyńska. "The morphological characteristics and technical preparation of 9-12 years old gymnasts", *Journal of Health Sci*, vol. 3, no. 13, (2013), pp. 163-177.
- [8] L. Louer, M. Elferink-Gemser, and C. Visscher, "The perfect elite gymnast, does he exist? A systematic review", *Ann. Res. Sport Phys*, no.3, (2013), pp 41-61.

## Author Info

*Corresponding author: [aleksic.veljkovic@gmail.com](mailto:aleksic.veljkovic@gmail.com)*

# Effects of 12-week corrective treatment on the postural status of younger school-age children

Tijana Šćepanović, Dragan Marinković, Dejan Madić, Branka Protić-Gava

*Faculty of Sports and Physical Education, University of Novi Sad, Serbia*

## **Abstract**

*The results of postural status assessment indicated the need for corrective gymnastics. For the purposes of this research, testing was carried out at schools on the territory of the Municipality of Bečej, followed by an experimental treatment for twelve weeks. The aim of the study was to test the effects of corrective treatment on postural disorders on a sample of 68 younger school-age children ( $7.44 \pm 2.01$  years of age). The total sample of randomized subjects was divided into two groups: experimental ( $N = 39$ ) and control group ( $N = 29$ ). The results obtained showed that the proposed 12 week treatment did not have statistically significant effects on changes in the locomotor apparatus so to improve the postural status of children aged 7.*

**Keywords:** *postural disorders, corrective treatments, Templo, posture analysis.*

## **1. Introduction**

Postural status can be defined as a combination of correctly positioned body segments when moving (Kendall, McCreary and Provence, 1993) and their mutual balance (Paušić and Dizdar, 2011). Poor posture implies a functional deviation from normal postural status, in which there are no structural changes of the spinal column or lower extremities and is characterized by the weakness of the whole organism, especially of the disco-muscular apparatus.

Postural disorders of children aged 7 are often associated with school and long-term seating on school chairs, which are often not adequate. In addition to inadequate classroom furniture, researchers say that the use of heavy school bags, as well as wearing them on one shoulder only, also have an impact on the



posture (Walicka-Cupryś, Skalska-Izdebska, Rachwał, Truszczyńska, 2015). A nonstandard bag increases the prevalence of lowered shoulders, kyphosis and lordosis (Zakeri, Shahram, Mahin, Vahid, 2016). All of the previously mentioned would not have a negative impact on the child's body if he/she was prepared in an adequate way so to withstand such an effort and burdening of the skeletal-ligamentar system. Children's growth in this age is accelerated, however, the bones are still insufficiently firm and are more susceptible to external influences. Intensive ointment occurs around the age of nine when the first peripheral parts of the body become firmer and and the same happens to the spinal column but only later. Through the study, Stanek, Truszczyńska, Drzał-Grabiec, Tarnowski (2015), prove a positive correlation between body height, body weight and postural stability. The higher and the heavier children are, they have better postural stability. Also, children actively engaged in sports have better vertical stability. Facco, Rossi, Pranke, Lemos (2013) prove that girls have better postural stability.

If a child does not (from the 4th year) get involved on time in a programmed exercise, which aims to strengthen the musculoskeletal system, he/she is more susceptible to the occurrence of postural imbalances in the form of changes in body segments. The following segments are particularly susceptible to changes: shoulders, blades and pelvis- the segments around the spinal column which retrieve the spinal column itself after certain period of time. The major role in the formation of proper body posture belongs to the abdominal muscles on the ventral, lateral and dorsal side.

The aim of the study was to test the effects of corrective treatment on postural disorders in younger school-age children.

## 2. Materials and methods

The study included 68 subjects,  $7.44 \pm 2.01$  years of age ( $BH = 125.60 \pm 5.39$  cm,  $BM = 24.89 \pm 4.50$  kg) from two primary school in Bečej. The total sample were randomized and each participant has the same chance of receiving of the experimental treatment. Allocation is carried out using a chance mechanism so that neither the participant nor the investigator will know in advance which will be assigned. Experimental and control groups are of a similar size and constitution so groups are alike in all important aspects and only differ in the treatment procedures. Subjects was divided into two groups: experimental ( $N = 39$ ) and control group ( $N = 29$ ). During experimental process and testing,

every subject from start to the end was included and there were no dropping out from research. As inclusion criteria, subject in experimental and control group were at least on 21 of training session. Groups were made based on Tests were carried out at schools on the territory of the Municipality of Bečej and are part of the research activities that the Faculty of Sport and Physical Education conducts after completion of the Ipa project ("Improving testing abilities on postural and spinal column status / SPINELAB" Grant Contract 2013/323-164). All measurements were carried out in accordance with ethical rules and each subject participating in the measurements was presented with an explanation of the procedure provided for the research and measurement.

Postural status of the spinal column is assessed using the contemporary photometric apparatus CONTEMPLAS GmbH TEMPLO that includes a camera system and software analysis for determining the position of the marked points in the space according to the 3D Posture Analysis protocol. This method represents the most modern way of measuring postural status by analysing all the necessary parts and axes of the body in a precise and simple way. When assessing the postural status, three cameras simultaneously shoot and analyse three perspectives of the body posture. Reflective marked balls were used in the analysis, enabling the most precise measurement of the postural status of the human body by non-invasive method. This method accurately measures the body posture, asymmetric standing, increased rotation in the shoulders and hips, the legs axis and the body posture viewed from the side. By automatic checking the marked fixed points on the skeleton, the software measures and assesses the body posture. In the test procedure, assessors set 16 reflective markers per subject, followed by placement of the subjects into calibrated space and photographing them with three cameras (Basler acA645-100gm/gc). Computer analysis has established the parameters that determine the status of the spinal column in the sagittal and frontal planes in the following variables:

Markers for assessing the status of the spinal column at the sagittal plane:

- Cervical lordosis - marked position of the seventh cervical vertebra in relation to the axis that passes vertically through the sacrum in the sagittal plane;
- Thoracic kyphosis - marked position of the most protruding vertebra of the chest curvature in the sagittal plane
- Lumbar lordosis - marked position of the most caved-in vertebra of the lumbar curvature in the sagittal plane

Markers for assessing the status of the spinal column at the frontal plane:

- Cervical scoliosis - marked position of the seventh cervical vertebra in relation to the axis that passes vertically through the sacrum in the frontal plane;
- Thoracic scoliosis - marked position of the most protruding vertebra of the chest curvature in the frontal plane;
- Lumbar scoliosis - marked position of the most caved-in vertebra of the lumbar curvature in the frontal plane.

The obtained results were then processed in the Templo 7.0 software and parameters for determining the postural status of the spinal column of the observed sample were established.

In order to obtain the necessary information on anthropometric measures, the testing procedures were conducted in accordance with the IBP (International Biological Program) standards using the Martin anthropometer and decimal scales. The sample of anthropometric measures was as follows:

- For estimating the longitudinal dimensionality of the body - body height (cm);
- For weight assessment (0.1kg).

The students involved in the research had regular physical education classes, twice a week. In addition to regular classes, the experimental group was additionally included in the corrective exercise program for 12 weeks (24 training session). The treatment included basic partner exercises for the correction of postural disorders of the functional type (Živković i Karaleić, 2014; Protić-Gava and Šćepanović, 2014). The work was organized according to postural group's i.e. primary postural disorders. The treatment lasted for three months and the exercises were performed twice a week for 45 minutes (one school class). Additional corrective exercise program included stretching protocols, strength protocols and activities for correcting bad posture and straightening body shape, which can help improve concentration and be continued after the study. Each training session were performed in progression manners and with all training principals. During research, supervisors and educated professors of PE were active on training session and help each of subject to perform exercises. The control group exercised weekly according to the standard curriculum.

Statistical analysis of the obtained data was carried out using the multivariate covariance analysis (MANCOVA) for the estimation of differences ( $p \leq 0.05$ ) in the entire system of sampled variables among the groups of subjects with initial testing as covariates. Univariate analysis of covariance (ANCOVA) revealed the difference ( $p \leq 0.05$ ) in individual variables of postural status among the age categories of subjects, where the initial calibration was made for the covariance. LSD post hoc analysis was used to understand the difference between pairs of groups. The entire statistical analysis was carried out in the software package SPSS 20.0.

### 3. Results and discussion

Assuming that the respondents of the experimental and control group had the same results in the initial measurement, which was done by calculating the adjusted arithmetic means, the final measurement determines how much the group has progressed. The results of the multivariate covariance analysis clearly indicate that there are no statistically significant differences between the groups of subjects in relation to the experimental treatment applied and changes in postural status in the sagittal plane (Table 1).

**Table 1. Differences in postural status in the sagittal plane**

Variable	K-AS		MD	f	p
	Experimental Group	Control Group			
Cervical spine	1,005	1,021	0,016	0,001	0,972
Thoracic spine	-1,470	-1,634	0,164	0,209	0,649
Lumbar spine	1,873	2,005	0,132	0,331	0,567
	F=0,583		p=0,628		

Legend: K-AS= estimated means, MD= mean difference (LSD), f= univariate, p= significant for univariate, F=multivariate, P=significant for multivariate.

The results of the univariate covariance analysis showed that experimental treatment did not significantly affect the postural status of subjects in the sagittal plane. Measured distances in all three parts of the spinal column are within the limits prescribed for this age, as confirmed by previous studies with a similar sample. In the research carried out by the group of authors Kovač, Kajmović, Rađo, Minić (2014), the distance of the lumbar curve ranges

approximately around 1.92, while a somewhat greater distance of the lumbar curvature was observed by Šćepanović, Marinković, Korovljević, Madić (2015), where it ranges around 2.103. The cervical and thoracic distances are proportional to the distance in the lumbar spine, which is normal. The thoracic curve has a negative indication, given the appearance of the spinal column- this value is normal since only the chest part of the spinal column has convection backwards.

Comparing the arithmetic means, from the initial and final measurement, there is a clear indication of the changes in both groups tested. Thus, the results of the initial measurement for the control group are: cervical = 0,499; thoracic = -2.129; lumbar = 1,531. In the final measurement (cervical = 1.013; thoracic = -1.666; lumbar = 1.966), the changes occurred, as the cervical curve increases, the thoracic decreases and the lumbar increases. Similar changes have also occurred in the experimental group, cervical increases (0.655 / 1.010), thoracic decreases (-1.839 / -1.446), and lumbar increases (1.816 / 1.901). However, the changes that occurred on the spinal column are negligible.

**Table 2. Differences in postural status in the frontal plane**

Variable	K-AS		MD	f	p
	Experimental Group	Control Group			
Cervical spine	-0,533	-0,828	0,295	2,953	0,091
Thoracic spine	-0,450	-0,667	0,217	2,066	0,156
Lumbar spine	-0,160	-0,254	0,094	1,724	0,194
	F=1,216		p=0,311		

Legend: K-AS= estimated means, MD= mean difference (LSD), f= univariate, p= significant for univariate, F=multivariate, P=significant for multivariate.

The spinal column observed in the frontal plane should be normal. The distance of the spine column segments actually shows how much it deviates from the vertical position to the left (negative indication) or to the right (positive indication). All the distances ranging around mean values are negative, indicating the presence of a spinal column curvature to the left (Table 2). The distance values are not large when observing the mean values. However, there are large individual differences if the minimum and maximum values are observed. At the individual plane there are positive changes that occurred in all three parts of the spinal column within the experimental group. However,

these changes are not statistically significant. In general, it is difficult to follow the mean values by observing the distances with different indications. Much more data can be obtained by observing minimum and maximum values. Thus, positive-indication curves (right) in the experimental group decreased and approached zero, i.e. they approached the vertical position of the spine (cervical = 2,053 / 1,172; thoracic = 1,491 / 0,894; lumbar = 0,549 / -0,171). On the other hand, left spine deviations did not have positive changes.

#### 4. Conclusions

The proposed experimental treatment did not lead to statistically significant transformation processes of the locomotor apparatus. The reason can be found in the length of the experimental treatment, as well as the dosage of exercise during each week. If the treatment could be carried out every or every second day, the effects of treatment would probably have been higher. During the treatment, a lot of time was spent on properly performing exercises and the real effects could only be expected after six or eight months. Considering age, stopping the occurrence and further progress of the disorder is immense progress. On the other hand, it is necessary to work on changing the awareness of poor body postural in children, as well as creating an image of nice, regular, healthy growth and development through all the body changes waiting for them in the period to come.

#### 5. References

Facco, A. R., Rossi, A. G., Pranke, G. I., & Cuzzo Lemos L. F. (2013). Influence of gender in postural balance of school age children. *Revista Cefac*, 15(3),528-537.

Kendall, F.P., McCreary, E.K., & Provance, P.G. (1993). *Muscles, testing and functions (4th ed.)*. Baltimore: Williams & Willkins.

Kovač, S., Kajmović, H., Rađo, I., & Manić, G. (2014). Trend projections of body deformities occurrence between the ages of 5 and 12, metrically objectified and estimated by 3D postural status screening. *Homo Sporticus*, 2(2014), 5-13.

Paušić, J., & Dizdar, D. (2011). Types of Body posture and their characteristics in boys 10 to 13 years of age. *Collegium Antropologicum*, 35(3), 747–754.

Protić-Gava, B. & Šćepanović, T. (2014). *Osnove kineziterapije i primenjena korektivna gimnastika*. Novi Sad: Fakultet sporta i fizičkog vaspitanja.

Šćepanović, T., Marinković, D., Korovljev, D., & Madić, D. (2015). Status kičmenog stuba u sagitalnoj ravni kod devojčica. *Proceedings of the 5<sup>th</sup> International Scientific Conference "Contemporary Kinesiology" – Split*.

Stanek, E., Truszczyńska, A., Drzał-Grabiec, J., and Tarnowski, A. (2015). Postural balance assessment in children aged 7 to 9 years, as related to body weight, height, and physical activity. *Biomedical Human Kinetics*, 7(1), 135–141.

Walicka-Cupryś, K., Skalska-Izdebska, R., Rachwał, M., & Truszczyńska, A., (2015). Influence of the weight of a school backpack on spinal curvature in the sagittal plane of seven-year-old children. *BioMed research international*, 2015.

Zakeri, Y., Shahram, B., Mahin, G., & Vahid, S. (2016). Relationship between Backpack Weight and Prevalence of Lordosis, Kyphosis, Scoliosis and Dropped Shoulders in Elementary Students. *International Journal of Pediatrics*, 4(6), 1859-1866.

Živković, D., & Karaleić, S. (2014). *Korektivna gimnastika*. Niš: SIA.

### Author Info

Dragan Marinković

E-mail: [marinkovicdragan@hotmail.com](mailto:marinkovicdragan@hotmail.com)

# The indomitable rise of eSports and synergy prospects with classical sport forms and kinesiology

Duje Petričević, Katija Kovačić

*Faculty of Kinesiology University of Split*

## Abstract

Once considered an aberration, a funny curiosity by most, seen as either a puzzling, fleeting fad, or a strange niche market that was to be strictly limited to Korea, eSports is now an interdisciplinary area on the rise. This study examines the perspectives of Croatian Olympians and professional sportspeople toward eSports, as well as the possibility of creating a synergic, interdisciplinary long-term relationship involving eSports, professional sports and kinesiology. Considering all of the interviewed people competed in team sports, the parallels were drawn with the team eSports staple game – Valve’s DOTA 2. Overall, there exists a uniformity of perspectives among the interviewed Olympians with regard to eSports and gaming in general, with a severe disconnect between classical sport disciplines and eSports. The latter is generally regarded as an implacable opponent, one that should be battled in order to safeguard both the physical and mental health of the youth.

**Keywords:** eSports, kinesiology, sport, synergy, Olympians, Croatia

## 1. Introduction

With the game theory being a staple of both economy and sport, and kinesiology holding the key to a healthy existence of every productive person, there is an interdisciplinary area gaining in both popularity and economic significance – the discipline of eSports. Like each interdisciplinary area, the origins and dynamics of eSports are complex, therefore, the history laid out will be quite abbreviated, encompassing only the most important events.



Some scholars, divide the history of eSports into two distinct, vastly different eras: the people-Vs-machine period and the people-Vs-people period (Donghun, 2011) . However, we opt to regard the true eSports discipline only from the latter standpoint, the people-Vs-people competition.

The spark that started eSports in the Western World was the advent of the networked FPS games, the “Doom” (1993) and “Quake” (1996), created by id Software. Named after the psychodynamic part of human personality structure containing instinctual drives, pronounced as [id], the team single-handedly created the mainstream FPS genre, as well as the nascent eSports in the Western World (Kushner, 2004).

The Eastern eSports scene was *created* by the RTS game “StarCraft” (1995), made by Blizzard Entertainment, which was, quite often jokingly and affectionately referred as the “Korean national sport”, with notable StarCraft: Brood Wars professional gamers visiting the Korean soccer team’s locker room whilst they were participating in the World Cup games, in order to motivate them to perform better - by meeting their idols. The Korean eSports scene was regarded as an aberration, a funny curiosity by most, seen as either a puzzling, fleeting fad, or a strange niche market that was to be strictly limited to Korea. However, this was just a benchmark of the vast untapped potential of eSports, the sign of things to come.

The Cyberathlete Professional League (CPL) was a pioneer of organizing professional video game tournaments. Its place in history was guaranteed when, in 1997, the CPL hosted its very first event, called The FRAG. The prizes consisted of merchandise worth 4.000 USD, with the total prize money for FRAG 2, held a year later, amounting to 15.000 USD in cash. The prize pool in 2001 totalled to 150.000 USD and was primarily provided by Intel. From 1997 to 2007, the CPL distributed more than 3.000.000 USD in cash and 2.000.000 USD in merchandise (Cyberathlete Professional League, 2017).

The Major League Gaming founder, Sundance DiGiovanni, expects eSports to achieve mainstream status by 2023 (Gaudiosi, 2013). The MLG was practically acquired on December 31, 2015, by Activision Blizzard, a staple company for the global computer games industry, for 46 million USD (Wingfield, 2016).

On the December 9, 2013, Danny Le, League of Legends player obtained a P-1A visa, a document reserved for internationally recognised athletes, thus becoming the first cleared professional video game player. He was closely

followed by a StarCraft 2 player, Kim “Violet” Dong Hwan, a 23-year-old South Korean. This was heralded as a great milestone for eSports, a sign of it moving into the U.S. mainstream (O’Neill, 2013). Recently, Sandbox eSports opened a “first of its kind” eSports training facility in California (Nairn, 2017). At present moments, professional eSports players receive athletic scholarships on universities and colleges throughout the World.

Additionally, it is a great shock to many that sport video games have actually *innovated* sport (Mullin, 2007).

Computer gaming, though generally considered as a negative or detrimental activity, is taking up a vast amount of time for the younger population, with computer games predating the formal education. Competence valuation from competition can have positive motivational effects on all individuals provided that valuation feedback is given properly (Fromme, 2003.). Children with high achievement motivation are likely to gain much ICT competencies from informal learning processes during competitive computer game play.

When comparing the eSports game patterns to their non-eSports or traditional sport involvement, both competition and skill had a statistically significant impact on time spent on eSports games, while peer pressure had a marginal significance (Donghun, 2011).

According to Madichie (2009), professional sports provide services to four distinct groups: the fan-base marked by attendance levels, viewership and purchase of team merchandise; television and other media; conglomerates acquiring exclusive broadcasting rights; government and other private investments in construction of sports facilities; to sponsorships or outright team purchases by corporations and even governments. The eSports perfectly fit all of these requirement.

When StarCraft 2 entered beta, Blizzard enlisted the professional StarCraft players to help test and balance it. It has been proven that eSports players are a valuable asset for the developers and publishers, since the most important and prolific companies need to position their new products with an eSports market. This is a very important sign of things to come and a signpost for the development of the entire industry.

Within the discipline of management, teams exhibiting a high degree of effectiveness with which they perform specialized various roles are called

“high-performance teams”. (Katzenbach, 2015). Thus, in essence, each sport team is a high-performance team. When MOBA (Multiplayer On-line Battle Arena) or any other team eSports match is played, it pits two opposing teams one against the other, which makes traditional team sport competition and eSports competition quite similar.

With professional NBA player, Jeremy Lin, drawing clear and unequivocal parallels between professional basketball and Valve’s DOTA 2 in the documentary *Free to Play*, to the very style in which the documentary is created, reminding one quite a lot of sport epics, tales of overcoming both external and internal obstacles, all for the chance of competing at the highest level, eSports seem to be extremely *sport-like*.

Furthermore, the demands on the motor skills of eSports professionals are extraordinary, with gamers achieving up to 400 movements on the keyboard and the mouse per minute, four times as much as the average person. The entire endeavour is asymmetrical, for both hands are simultaneously moved and various parts of the brain are also used at the same time. While it looks to the layman as if the players are furiously, randomly punching their keyboards and moving their mice, strategy games are quite complex, requiring a high degree of tactical understanding in order to achieve victory. At the same time, the pulse races as high as 160 to 180 beats per minute. In terms of fitness, most of the eSports professionals are average people, which is a great hindrance. Exercises that would strengthen the whole support system in the shoulder and neck areas would improve their fine-motor skills in the arm area, which is crucial for competing at such a high level. Also, better nutrition is another, absolute necessity (Rudolf, 2016). It is not shocking, then, that the players engaged in eSports activities, aged on average between 18 and 22 years, are experiencing health complications after practicing as much as 14 hours a day to retain their professional status (Hollist, 2015). Their careers usually end in mid-20’s, with an incredibly short period of professional engagement.

The sedentary lifestyle of eSport participants needs to be offsetted by incorporating daily physical activity, with gamers who exercised regularly, generally outperforming those who didn’t (Stanton, 2015).

As predicted by the official, filed Razer IPO prospectus, the global eSports market is projected to grow at the 14,6% compound annual growth rate, starting from 2017. The Table 1 shows this projected increase until 2021.

**Table 1:** The global eSports market growth, projections until 2021.

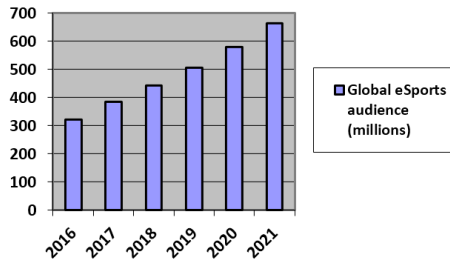

DOTA 2, a staple of the global team eSports, has a yearly competition – The International, in essence, the World championship of DOTA 2, a MOBA computer game pitting two teams of five players against each other. It is made and organised by Valve and has been increasing its prize pool since the very inception. The first International, held in 2011 in Cologne, Germany, had, at the time, a preposterous overall prize pool of 1.600.000 USD. It was a chance for Valve to promote DOTA 2 as a global eSport. The team “Natus Vincere”, from Ukraine, took the crown and became the protagonists of the entire championship. The following year, the prize pool stayed the same, with Valve relocating the tournament to Valve’s home state – Washington, where it remains to this very day. The Chinese team, Invictus Gaming took home one million USD in 2012. During the 3<sup>rd</sup> International, in 2013, Valve allowed for the first time for the community to generate a greater prize pool for The International, with its innovative, interactive Compendium, by means of allocating 25% of the Compendium purchases straight into the prize pool. The community bumped the prize pool from 1.600.000 USD, again, provided by Valve, to a total of 2.874.380 USD. The following year saw the Compendium purchases soar, totalling to a staggering 10.923.977 USD. The growing trend continued, with the total prizes amounting to 18.429.613 USD in 2015 and 20.770.460 USD in 2016. Table 2 shows the increase of The International’s prize pool.

**Table 2:** The International prize pool, indicating Valve’s share, community’s share, and the overall prize pool

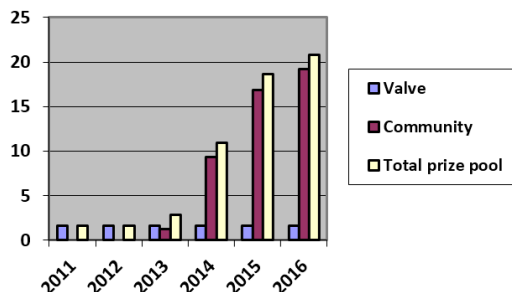

When put into percentage point increases, with regard to the previous year's prize pool, the rise is practically constant ever since the Valve created the Compendium and allowed the community to participate in forming the prize pool. Therefore, the rise in 2012 was at 0 percentage points (because just the Valve provided the prize pool, at 1.600.000 USD), at 79,65 percentage points in 2013, 280 percentage points in 2014, 69 percentage points in 2015, 13 percentage points in 2016. This percentage point increase is shown in Table 3.

**Table 3:** The International total prize pool, indicating the rise as a percentage point of the previous year's prize pool

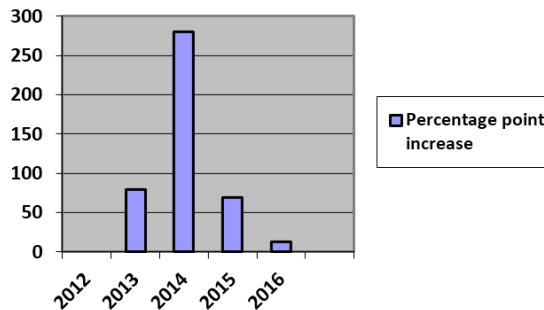

## 2. Materials and methods

The empirical research carried out consisted of an in-depth interview with an expert sample of 6 professional sportspeople, 5 of them former Olympians who were all awarded Olympic medals based on their extraordinary achievements. Each person also operated and currently is involved within the domain of sport management in his / her secondary career. Five interviewed were male, a single person female, ranging in age between 41 and 64 years, with a mean value of 53 years, participating in the following team sports: basketball, water polo, handball and rowing. A funnelling technique was used, so additional, more complex questions were gradually presented as the interview progressed. The subjects have been encouraged to freely express the attitudes and thoughts based on a wide arrange of subjects, mostly dealing with sport, sport management, education and entrepreneurship.

All of the interviews were carried out by an interviewer and recorded on a smartphone, with another researcher going over the information obtained several times, ultimately extracting the data. These two research roles were quite purposefully separated, in order to eliminate bias as much as possible, since the person extracting data never communicated nor met with the subjects interviewed.

The checklist, utilised by the interviewer, is as follows, laid out in a numerical, sequential order:

1. Have you heard of eSports? (*A short explanation in case the subject never heard of eSports*)
2. In your personal opinion, does this form of competition have a potential of eventually having an equal degree of importance as the classical sport disciplines?
3. What are your thoughts on people receiving student scholarships based on their eSports accomplishments?
4. In your personal opinion, can professional eSports participants be regarded as sportspeople?
5. Can there ever be a synergy between eSports and classical sports or are they two fundamentally differing “activities”?
6. In your personal opinion, can professionals employed in classical sport entities contribute to eSports?

### 3. Results and discussion

The interview results were extremely similar for all the subjects interviewed, with a staggering degree of uniformity and a minimal to non-existent variability with regard to the research issue.

The overall degree of familiarity of the interviewed Croatian Olympians and professional sportspeople with eSports is almost none-existent (with an exception of a single individual). It should be further mentioned that the DOTA Pit Season 4 and 5 tournaments were held in Split, Croatia, from January 19.-22. 2017. and 19.03.-20.03.2016 respectively.

The interviewed subjects rejected even the slightest possibility of eSports ever coming close in popularity and/or profitability to the classical sports. In essence, the subjects are convinced that eSports will never attain the sport status, for classical sports and “eSports” are, essentially, implacable enemies, the latter signifying atrophy and isolation of the youth. A single research participant even went so far as to compare gaming in general to the practice of *gambling*. Every person shares this negative perspective on gaming, with a particularly strong opposition to eSports. Just one subject differed from the consensus, but it should be noted that the person in question had professional

dealings with eSports. Additionally, the mentioned sportsperson, although recognising both the potential of eSports and the possibility of a synergy between professional sports, kinesiology and eSports, however, is still quite unsure whether it is, or ever will be, a sport in every sense of the term.

Admittedly, it is quite difficult to make conclusions based on an expert sample of only 6 accomplished sportspeople, 5 of them Olympians, awarded Olympic medals for their extraordinary achievements. Furthermore, the mean age of the participants is 53, so perhaps a very strong generational bias exists. All of the people interviewed admitted at some point that they did not grow up with computers or gaming consoles, not even the youngest member of the sample (aged 41). The authors recommend that another, much more comprehensive research utilising an in-depth interview, coupled with a Likert scale survey, on a fairly greater sample, ultimately utilising the power of inferential statistics in order to determine whether generational bias is statistically significant and what are the most statistically probable perceptions of professional sportspeople, awarded Olympians and kinesiologists toward eSports.

Furthermore, specialized companies dealing with professional eSports peripherals emerged, offering mousepads, computer mice, monitors, etc. An experiment, pitting three specialized mouse pads against each other showed no impact on performance, with the kinematic data having no statistically significant difference between a specialized mouse pad, a traditional mouse pad, and no mouse pad at all. The results suggest that manufacturers claim of increased performance cannot be empirically corroborated (Slocum, 2005). Kinesiologists may be able to help these companies when designing these products, offering expertise and help to both the gaming industry in general, as well as eSports.

The eSports are on the verge of mainstream success, with lucrative sponsorships and widely present match broadcasts just around the corner, and the undeniable opportunity for the employment of sport professionals and kinesiology experts. The kinesiology experts and classical sport professionals that enter the nascent eSport will become the indispensable support for the entire discipline.

Overall, more research is needed in this particular interdisciplinary area, both from a scholarly and a professional standpoint.

The missed opportunity for establishing a positive social interaction, achieving profit, creating value, connecting traditional, professional sports to

eSports, while helping out professional eSports athletes with their grueling training regimes through the kinesiology discipline and, in essence, giving rise to a synergic relationship materialized in numerous entrepreneurial, long-term businesses and projects is an important one.

#### **4. Conclusions**

The eSports are on the verge of mainstream success, with lucrative sponsorships and widely present match broadcasts just around the corner. The kinesiology experts and classical sport professionals that enter the nascent eSports will become the indispensable support for future successful eSports teams and potential professional participants, big brands of the future.

Although, at present, most of the Croatian interviewed Olympians and successful sportspeople fail to see the possibility of a synergic relationship between eSports, classical sports or kinesiology, the opportunity of a long-term, mutually beneficial relationship is quite present. There also exists a resistance and negative perception toward gaming in general, with eSports provoking a sense of shock and incomprehensibility and the entire discipline being perceived not only as “the other”, but as an implacable opponent, one that should be actively combated in order to safeguard both the bodies and minds of the youth. At present, the sense of indifference toward eSports by Olympians and professional sportspeople would be quite an improvement. In general terms, there exists a fundamental disconnect between classical sports and eSports in the minds of the most successful facet of classical sport participants.

The eSports, professional sports and kinesiology will be hindered by these perceptual patterns and attitudes, with the lost opportunity in terms of overall progress, betterment of health and higher profit, particularly with regard to the fact that eSports is on the verge of becoming a mainstream, fully-fledged sport in every possible sense of the term. Lastly, professional eSports athletes are subjected to grueling training regiments and extraordinary demands on motor and mental capacities.

#### **5. Reference**

Cyberathlete Professional League. (2017, July 1). Retrieved from <http://theopl.com>



Donghun, L. S. (2011). Comparison of eSports and Traditional Sports Consumption Motives. *The ICHPER-SD Journal of Research in Health, Physical Education, Recreation, Sport & Dance*, 39-44.

DOTA 2 Prize Pool Tracker. (2017, July 1). Retrieved from DOTA 2 Prize Pool Tracker Web site: <http://dota2.prizetrac.kr>

DOTA Pit. (2017, July 1). Retrieved from DOTA Pit Official Web site: <http://www.dotapit.com>

*Free to Play* (2014). [Motion Picture].

Fromme, J. (2003.). Computer Games as Part of Children's Culture. *The International Journal of Computer Game Research*.

Gaudiosi, J. (2013, March 15). *Forbes*. Retrieved from MLG Founder Sundance DiGiovanni Believes eSports Will Be Mainstream Within 10 Years: <https://www.forbes.com/sites/johngaudiosi/2013/03/15/mlg-founder-sundance-digiovanni-believes-esports-will-be-mainstream-within-10-years/#795e7080777f>

Hollist, K. (2015). Time to be Grown-Ups About Video Gaming: The Rising eSports Industry and the Need for Regulation. *Arizona Law Review*, 824-844.

Katzenbach, J. S. (2015). *The Wisdom of Teams: Creating the High-Performance Organisation*. Harvard Business Review Press; Reprint edition.

Kushner, D. (2004). *Masters of Doom: How Two Guys Created an Empire and Transformed Pop Culture*. Random House Trade Paperbacks.

Madichie, N. (2009). Professional Sports: A New "Services" Consumption Mantra in the United Arab Emirates. *The Marketing Review*, 301-318.

Mullin, B. J. (2007). *Sport Marketing*. Human Kinetics.

Nairn, V. (2017). Sandbox eSports Opens as "First of its Kind" eSports Training Facility in California. *Slingshot*.

O'Neill, P. (2013). First "StarCraft 2" Player officially recognized as an Athlete by U.S. Government. *Dot eSports*.

Razer Inc. (2017, July 1). *Hong Kong Stock Exchange*. Retrieved from Hong Kong Stock Exchange Web site: <http://www.hkexnews.hk/app/SEHK/2017/2017062803/Documents/SEHK201706290041.pdf>

Rudolf, K. G. (2016). Stress Im eSport - Ein Einblick in Training und Wettkampf. *eSport Konferenz "Professionalisierung einer Subkultur?": Bayreuth, Deutschland*.

---

Slocum, J. T. (2005). Evaluation of Mouse Pads Designed to Enhance Gaming Performance. *Proceedings of the Human Factors and Ergonomics Society Annual Meeting*.

Stanton, R. (2015, May 29). *ESPN*. Retrieved from The secret to eSports athletes' success? Lots -- and lots -- of practice: [http://www.espn.com/espn/story/\\_/id/13053116/esports-athletes-put-hours-training-reach-pinnacle](http://www.espn.com/espn/story/_/id/13053116/esports-athletes-put-hours-training-reach-pinnacle)

Wingfield, N. (2016, January 04.). *The New York Times*. Retrieved from Activision Buys Major League Gaming to Broaden Role in eSports: [https://www.nytimes.com/2016/01/05/technology/activision-buys-major-league-gaming-to-broaden-role-in-e-sports.html?smid=tw-share&\\_r=1](https://www.nytimes.com/2016/01/05/technology/activision-buys-major-league-gaming-to-broaden-role-in-e-sports.html?smid=tw-share&_r=1)

### **Author Info**

Corresponding author: Duje Petričević ([duje\\_petricevic@yahoo.com](mailto:duje_petricevic@yahoo.com))

## Comparing the legal framework of adventure tourism

Marina Kostović Papak<sup>1</sup>, Katija Kovačić<sup>2</sup>, Duje Petričević<sup>2</sup>

<sup>1</sup>University Department for Forensic Sciences University of Split

<sup>2</sup>Faculty of Kinesiology University of Split

### Abstract

*The adventure tourism forms represent a specific tourism niche within the sport tourism market, experiencing an above average rate of growth and profitability. Tourist consumers, both within the domains of soft and hard adventure tourism, while consuming various exercise forms, are exposed to unusually high degrees of risk, which are not covered by the standard sport insurance policies. Croatia has, similarly as the other tourism countries competing on the adventure tourism market, developed a legislature framework legally regulating the risk insurance for the consumers of adventure tourism products and/or services. This paper examines the existing legal framework, regulating the rights and regulations of all the participants dealing with the adventure tourism of various countries, with the proposed regulatory recommendations for the further development of the Republic of Croatia's legislative framework.*

**Keywords:** *adventure tourism, legal aspects, risk, insurance, Republic of Croatia*

### 1. Introduction

The sport tourism and especially the adventure tourism, as a distinct variety of sport tourism, represents one of the most propulsive global tourism sectors. During the last few years, the adventure tourism records an exponential growth, affirming itself as a new, recognisable and attractive tourism market for tourism consumers throughout the World (Global Report on Adventure Tourism, UNWTO, 2014). The Adventure Travel Trade Association defines adventure tourism as a trip that includes at least two of the following

three elements: physical activity, natural environment and cultural immersion (Global Report on Adventure Tourism, UNWTO, 2014). For instance, rafting on the river Cetina consists of engaging in physical activity, canoeing / kayaking through an attractive, natural landscape, as well as the opportunity to sample traditional cuisine in local restaurants, giving ample opportunity at experiencing cultural immersion. Tourist consumers, both within the domains of soft and hard adventure tourism, satisfy a whole array of various needs, ranging from physical activity and overcoming challenges, to enjoying the socialization process and the natural beauty of a tourist locale.

The adventurous tourism market includes the entrance of new, relatively unknown tourist destinations almost daily, which also brings a wholly new, distinct groups of tourist consumers. The touristic countries which abound in attractive natural resources, through the development of adventure tourism forms, strive to draw in new segment of tourist consumers, thus extending the overall duration of the tourist season. The adventurous tourism forms simultaneously brings significant revenues, is not excessively invasive from the aspect of the natural environment and is ultimately in line with the EU's strategy for the sustainable tourism development.

Tourism consumers are prepared to pay a premium price for an unforgettable tourist experience, filled with adrenaline-inducing risks which have the distinct possibility of ending in disaster. Adventure tourism operators have reported an average of 3.000 USD spent per person, with an average trip length of eight days (Adventure Travel Trade Association, industry snapshot for year 2014). The global adventure tourism is increasing both with regard to the market supply, as well as the demand, with the overall number of tourism consumers rising and their allocated expenses for a quality sport and tourism experience increasing, when compared to previously expended monetary volume. Coupled with these modern trends, the offer of adventure tourism experiences is getting more varied and increasingly interesting, because of the decreased market entrance barriers. New, relatively unknown tourism destinations and novel adventure tourism forms represent an everyday present market occurrence. Considering that this particular tourism form is inextricably tied to high, non-standardised risks, the formation of a quality regulatory framework represents a crucial component in both protecting all the participants and preventing an uncontrolled entrance of new providers, ones unable to fulfil all the safety regulations and thus offer a quality service/ product.

The law regulating the tourism services defines adventure tourism forms as tourism services encompassing sport, recreational or adventure activities. The law cites an example of skiing, mountain climbing, rafting, paragliding, bungee jumping, white-water rafting, horseback riding, diving, canoeing and the like. The extreme sports are not included *per se*, with the possibility left open to update the list with other forms of sport adventure activities. Within this particular context, a few activities should be mentioned, such as base jumping, skydiving, paintball, mountain biking, extreme biking, ice climbing, kitesurfing, free climbing, sport climbing, expedition racing, water skiing and trekking. Considering the Republic of Croatia's potential with regard to the abundance of natural resources and the popularity level of the previously mentioned sport forms, the list of such activities has a potential for future substantial growth.

Within the Tourism Development Strategy of The Republic of Croatia until 2020, the adventure and sport tourism has been singled out as possessing vast potential for an overall tourism development. Considering this is an increasingly important and fast-growing product segment, with the recorded growth of 30%), the adventure tourism offer is continuously being developed, especially in the coastal and mountainous regions of the Republic of Croatia. Predictions especially point out to a greater probability of adrenaline sports gaining in importance within the current non-tourism destinations, which is completely in line with an increased need for an active vacation spent in nature.

Tourist consumers, both within the domains of soft and hard adventure tourism, while consuming various exercise forms, are exposed to unusually high degrees of risk, not covered by the standard sports insurance policies. The countries competing in adventure tourism forms are developing a legislative framework, attempting to legally regulate risk insurance covering the tourism customers within the domain of adventure tourism.

In the Republic of Croatia, a provider of sport-recreational or adventure activities is bound by the Law on Provision of Services in Tourism to inform the customer of various risks that may occur, in both the written and oral forms. Lastly, it is required that the customer is insured from an accident. It is of the utmost importance that the service provider familiarizes the users with all possible consequences which can arise as a result of engaging in extreme sports. This is intended to make sure the user is aware of all the risks involved, since the act of engaging in extreme sports involves a probability of a lethal accident.

Let's take, for example, a recent case in which a young biology professor, otherwise an experienced skydiver, died in Bovec, Slovenia. According to a police report, a young female biology professor, jumped for the plane at 12:14 pm, at a height of 4.000 metres. Following her, six more skydivers jumped out. After completing a figure holding hands, the skydivers parted and started to open parachutes. The main parachute of the now deceased female skydiver failed to open, so it was discarded at 800 metres, after which she started deploying the reserve parachute. Since the deployment cord was wrapped around her body, the reserve parachute also failed to deploy. At 12:15 pm she fell on the runway while in free-fall and perished on the spot.

The above-mentioned case also points to the diverse risks to which adventure tourism consumers are exposed to, particularly when compared to other tourism forms. Extreme sports are therefore excluded from the standard sports insurance policies because the risk or the perception of risk is quite higher. Consequently, insurance contracts in adventure tourism have been formed to reflect this, increasing the insurance premiums.

## **2. Materials and methods**

The fundamental research method utilised in this paper is the comparative law method, the study of the relationship between legal systems and existing regulatory framework, namely, those of the Republic of Croatia and the following countries: Republic of Ireland, Australia, New Zealand and UK, with regard to the adventure sport tourism and extreme sport tourism laws. It is the study of the relationship existing between rules of more than one system, their differences and similarities (Butler, 2011).

This method is ultimately paired with the benchmarking method, the search for industry best practices that lead to superior performance, by examining the ways in which Croatia can better its' own sport adventure tourism and extreme sport tourism regulatory framework, giving rise to increased economic performance and overall progress.

## **3. Results and discussion**

In accordance with the Law on Provision of Tourism Services of the Republic of Croatia, as already stated in the previous section, it is mandatory for providers of sport recreational or adventure activities to acquaint customers with the

types of risks that may result as a result of the chosen service, in both written and oral form, along with the obligation of being provided insurance. There are namely two types of insurance that provide protection to service users for sport recreational or adventure tourism activities, the third party insurance and accident insurance. The first is aimed at providing damage compensation caused to third parties, while the second provides protection for the insured person in the event of bodily injury.

The compulsory insurance policy between the service provider and the customer, covering accidents, includes a daily recompense of treatment costs, in case of a permanent disability or accidental death. This can be extend to other forms of damages, depending on the particular type of insurance the company is offering. The premium is dependent on the risk category a particular extreme sport belongs to, which is ultimately determined by the insurance company regulations put into place.

Given that extreme sports in adventure tourism are regularly associated with high risks, both in regard to the customer, as well as the third person, it would be necessary to prescribe the statutory provision of the compulsory insurance, for the harm caused by the user of services to third parties. According to the existing arrangement, the user of the service may additionally, in addition to the compulsory accident insurance, also arrange the liability insurance for damage caused to third parties. However, if the user has not additionally contracted such a policy and the damages do occur, the mandatory civil liability law rules apply, which in practice often results in a quite lengthy compensation procedure.

Juveniles may engage in sport recreational or adventure activities only with the written consent of parents or legal guardians. Irrespective of whether a minor has a consent of a parent or a legal guardian, the law enables the service provider to refuse to provide the service to that particular person.

According to the Law on Provision of Tourism Services, a legal person shall be punished for a misdemeanor with a fine totaling from 8.000 to 100.000 HRK, if the tourist sport recreational and adventure services are not provided in accordance with the Article 56 of the said Act. For the same offense, the natural person shall be punished by a fine of 8.000 to 15.000. HRK. The tourist inspector may punish the natural person at the place of execution of the offense in the amount of 2.500 HRK. The head of the branch office will be punished with the fine, for the mentioned offense, ranging from 3.000 to 15.000 HRK, whereby

the tourist inspector may punish the head of the branch office at the place of execution of the misdemeanor with the amount of 2.500 HRK.

It is important to note that participation in certain extreme sports within the Republic of Croatia requires a fulfillment of additional criteria, prescribed for that specific sport type, which is regulated by a subordinate legislation. For example, the Ordinance on Underwater Activities stipulates that diving should only be done by persons who hold a valid diving certificate, which excludes the duration of the training process.

The Croatian Mountain Rescue Service (hereinafter referred to as HGSS), plays a major role in education, prevention and ensuring of a safe realization of extreme sport activities. HGSS is a non-profit, governmental organisation that carries out activities of interest to the Republic of Croatia. Pursuant to the Article 13 of the Croatian Maritime Rescue Services Act, the participants of tourist, sporting and other activities carried out in mountainous and other inaccessible areas are obliged to observe the safety instructions and warnings set out by the HGSS.

Namely, the HGSS provides the Safety Rules on Measures and Rules of Conduct for Persons Involved in Mountain Activities and Other Inaccessible Areas (hereinafter: Safety Rules), that serve as recommendations and advice to people participating in activities in the mountains and other inaccessible areas. The general measures and rules of conduct for the activities in the mountains and other inaccessible areas prescribed by the Security Rules, consists of (1) information with regard to the essential characteristics of the area where the activity is planned to take place, (2) information with regard to the weather conditions in the area foreseen for the planned stay, (3) physical, psychological and health-related ability needed to perform the desired activity (4) wearing adequate clothing, footwear and having necessary equipment, (5) having adequate supplies of food and drink for use during the activities, (6) no alcohol consumption, (7) informing a family member with regard to the planned route and duration of the activity, (8) compliance with the schedule and (9) possession of the first aid kit and a fully charged cellular phone. In the case of a weak cell phone signal, if necessary, the recommendation is to try to make contact via SMS.

In addition to the general measures and rules of conduct, the Safety Rules are also divided according to the types of activities, on specific measures and rules of conduct, ones intended to apply to hiking, climbing, mountain



and trekking racing, skiing and sledding, speleology, round skiing and other various activities within the inaccessible areas. In conclusion, it should be noted that the Ministry of Tourism of the Republic of Croatia prepared a Draft Proposal for the Tourism Services Act, put currently to public debate. The new draft further details and additionally prescribes forms of tourist offer related to tourist services of active and adventurous tourism, which are considered to be insufficiently regulated to date.

Unlike the Republic of Croatia, some countries have been much more stringent when regulating the adventurous activities, which also includes the extreme sports. For example, in the United Kingdom, a specific authority is tasked with issuing work permits to adventure tourism entities - the Adventure Services Licensing Authority (AALA). It is the task of this body to ensure that the companies dealing with adventure tourism meet all the safety criteria, with regard to the employee expertise and know-how, as well as the technical validity of the equipment used. The authority itself issued guidelines all the adventure tourism entities should adhere to, namely, (1) the obligation to inform the user of the risks involved, (2) strict supervision of the staff with regard to equipment use, (3) supervision over the equipment used, (4) established emergency intervention procedures in case of an accident, so medical and other authorized bodies can act swiftly, with the aim of minimizing the damage, etc.

In Ireland, a draft of rules relating to extreme sports, called The Blueprint has been developed. The Blueprint is provided by the Department of Communication, Marine and Natural Resources, containing the security rules with regard to extreme sports. A particular attention is given to the providers of extreme sports tourism services. Security rules were developed as a result of consultations within the adventure sports sector, led by the Association for Adventure Sports.

The first recommendation, stemming from the discussed security policy is that the service providers must register with an adequate authority (namely, the Adventure Activities Standards Authority), which is responsible for both registering the adventure service providers as well as determining the standards required of the providers to commence their operation. It is then recommended that the said body includes at least four service providers' representatives, as well as four state authority representatives (from the Ministry of Ports and natural resources, Health and security, Education and

Tourism), and to carry out both announced and unannounced surveillance over service providers, dealing with their reports, documentation, technical equipment, qualified staff, etc.

Unlike the European solutions to the issues plaguing the adventure tourism, the Australian and New Zealand Sports Law Association (hereinafter referred to as ANZSLA), has been instituted in 1990 as the main non-profit, legal organisation responsible for sport law and devoted to education, professional legal assistance and socioeconomic network creation on legal issues in sports, which also includes the area of extreme sports. The ANZSLA members are made up of lawyers, academics, government representatives, students and many others, who all share a common interest in sport. The organization has an open membership, accepting everyone sharing these mutual interests.<sup>1</sup> The goal of ANZSLA is to familiarize both the service providers and users with their rights and obligations, as well as to provide them with adequate training in order to reduce the overall degree of risk to which all the adventure and extreme sport participants are exposed to.

With regard to the accelerated development of tourism within the Republic of Croatia, which is coupled with the growing demand for adventure tourism forms, it is an absolute necessity for the Republic of Croatia to systematically and in greater detail regulate the rights and obligations of both the service providers and the users of the above mentioned services. This will ultimately serve to increase the oversight over the entire business sector, eventually resulting in the establishment of a basic safety criteria, thus reducing the overall risk, especially for the service users.

#### **4. Conclusions**

By utilising the comparative law method, the paper examined the regulatory framework governing the insurance and functioning of both the adventure and extreme sport tourism forms within the Republic of Croatia, contrasting it to the Republic of Ireland, Australia, New Zealand and the United Kingdom. With the regulatory framework in its infancy, Republic of Croatia can benefit from the experiences and structures formed by other countries with a legacy of both the adventure and extreme sport tourism. Taking from the UK's example, Croatia should establish an authority strictly tasked with the

---

<sup>1</sup> The Australian and New Zealand Sports Law Association, web page: <http://anzsla.com>, accessed on 01.07.2017.

adventure tourism, following the Ireland's example, an overarching blueprint, based on long-term strategic planning should be achieved. Lastly, following the example set by the Australian and New Zealand Sports Law Association, the supporting regulatory mechanisms should be established, with the open membership policy, open to the entire socioeconomic network dealing with the adventure and extreme sport tourism.

Only a functioning, sustained regulatory framework, supporting sport and adventure tourism, can guarantee the Croatia taking advantage of this lucrative, rising sport and economic activity.

## **5. References**

- [1] Mićović, M., „Sport insurance: Collected Papers of the Faculty of Law in Split“, vol. 49, Issue 4 (**2012**), pp. 741.-749
- [2] Proso, M., „Sport insurance: Collected Papers of the Faculty of Law in Split“, vol. 47, Issue 2 (**2010**) pp. 411-425.
- [3] Butler, W. K., „Foundations of Comparative Law: Methods and Typologies“, Wildy, Simmonds & Hill, London, (**2011**).
- [4] Article 5, Ordinance on performing underwater activities, Official Gazette no. 47/99, 23/03, 28/03, 52/03 and 58/03.
- [5] Article 13, § 1 of the Croatian Maritime Rescue Services Act, Official Gazette no. 79/06 and 110/15.
- [6] Article 56. § 1 of the Law on Provision of Services in Tourism, Official Gazette no. 68/07, 88/10, 30/14, 89/10 and 152/14.
- [7] Article. 56, § 2 and 3 of the Law on Provision of Tourism Services, Official Gazette no. 68/07, 88/10, 30/14, 89/10 and 152/14.
- [8] Article 56, § 4 and 5 of the Law on Provision of Tourism Services, Official Gazette no. 68/07, 88/10, 30/14 and 89/10, 152/14.
- [9] Article 62, § 7 of the Law on Provision of Tourism Services, Official Gazette no. 68/07, 88/10, 30/14, 89/10 and 152/14.
- [10] Strategy of Republic of Croatia's tourism development until the year 2020, Official Gazette no. 68/07.
- [11] Adventure Travel Trade Association, industry snapshot for 2014, web page: [http://www.ncetourism.com/wp-content/uploads/2016/10/b4-Presentation\\_ATTA-Industry-Snapshot-2014.pdf](http://www.ncetourism.com/wp-content/uploads/2016/10/b4-Presentation_ATTA-Industry-Snapshot-2014.pdf), accessed on 01.07.2017.

- [12] Association for Adventure Sports, Ireland, The Blueprint web page: <http://www.adventuresports.ie/licauthsubm.html>, accessed on 01.07.2017.
- [13] Health and Safety Executive, Adventure Activities Licencing Authority, web page: <http://www.mint.hr/default.aspx?id=40523>, accessed on 01.07.2017.
- [14] HGSS Safety Rules, available on the web page: <http://www.gss.hr/savjeti/sigurnosna-pravila-hgss>, accessed on 01.07.2017.
- [15] UNWTO Global Report on Adventure Tourism, 2014. Web page: <http://affiliatemembers.unwto.org/publication/global-report-adventure-tourism>, accessed on 01.07.2017.
- [16] Ministry of Tourism, Republic of Croatia, web page: <http://www.mint.hr/UserDocsImages/130426-Strategija-turizam-2020.pdf>, accessed on 01.07.2017.
- [17] Ministry of Tourism, Republic of Croatia, web page: <http://www.mint.hr/default.aspx?id=40523>, accessed on 01.07.2017.
- [18] Telegraf, Web page: <http://www.telegraf.rs/english/2828632-marina-lived-for-skydiving-the-horrible-details-of-the-tragedy-in-which-a-young-biology-professor-lost-her-life>, accessed on 01.07.2017.
- [19] The Australian and New Zealand Sports Law Association, web page: <http://anzsla.com>, accessed on 01.07.2017.

### Author Info

*Corresponding author: Marina Kostović Papak ([marinicca@gmail.com](mailto:marinicca@gmail.com))*

## Aerobic capacity of handball players with hearing impairment

Milica Đukić, Dragoslav Jakonić, Milorad Đukić

Faculty of sport and physical education University of Novi Sad Serbia

### Abstract

**S**tudy aim: To determine the aerobic capacity of handball players impairment as compared with the healthy ones. Material and methods: Two groups of subjects took part in this study: healthy national handball players (NHB;n=15) aged 18-33 years and international handball players with hearing impairment (IHB;n= 13), winners of European Deaf-Mute Championships in 2008 ( Belgrade, Serbia) and second place in Deaflympic games in 2009 (Taipei, Taiwan), aged 21-48 years. Cosmed T-170 treadmill (FSPE1 protocol) and a breath-by-breath gas analyser were used to determine the following indices of aerobic capacity: maximal heart rate (HRmax),  $VO_2$ max, oxygen pulse, lung ventilation, tidal volume, maximum speed. results: Players from the IHB group attained significantly ( $p < 0.05 - 0.01$ ) lower values of oxygen pulse and maximum speed (by 12%), heart rate 1 min post-exercise (by 6%), lung ventilation (by 11%) and tidal volume (by 14%) compared with NHB group. IHB players had also twice lower weekly training volume. On the other hand no significant between-group difference was found for the relative  $VO_2$ max. Conclusion: The lower results attained by handball players with impaired hearing compared with the healthy ones could be attributed to lower training volume per week. Thus, an increase in the training volume for the disabled players would be recommendable

**Keywords:** spiroergometry – maximal oxygen consumption - handball

### 1. Introduction

Hearing disability is best defined as a lack or reduction in the ability to hear clearly due to disorders in the hearing mechanism. That disorder limits the functioning of disabled individuals in the community and, in addition,

affects their engagement in motor activities [1,9]. Some studies revealed that the level of physical activities of children with hearing loss was significantly lower compared with their healthy mates [21]. Impaired hearing affects the development of balance as a consequence of damages in the vestibular apparatus and its connections with higher nervous structures [1,8]. Nonetheless, subjects with hearing impairment are very often engaged in sport activities, and participate in competitions at all levels, from local to ParaOlympic Games.

Handball represents a complex, intermittent team game which requires that players have high aerobic and anaerobic capacities [10,11]. Aerobic capacity is a generalised feature of all metabolic processes contributing to the global work capacity of an athlete [12]. Maximal oxygen consumption ( $\dot{V}O_2^{\max}$ ) has been commonly used as a criterion of aerobic capacity and used in physiological monitoring of athletes [5,9] and is considered the best index of aerobic capacity [1,7,10]. The  $\dot{V}O_2^{\max}$  is defined as the highest attainable oxygen uptake for given form of ergometry irrespectively of further increases in the work rate and effort [13]. The data on a laboratory assessment of aerobic capacity are not numerous [14,17] and no reports on that issue were found with respect to handball players with hearing impairment. Thus, the aim of this study was to determine the aerobic capacity of handball players with hearing impairment and to compare them with healthy handball players.

## 2. Materials and methods

*Subjects:* Two groups of subjects took part in this study: healthy national handball players (NHB;  $n = 15$ ) aged 18-33 years and international handball players with hearing impairment (IHB;  $n = 13$ ), winners of European Deaf-Mute Championships in 2008 (Belgrade, Serbia), and second place in Deaflympic games in 2009 (Taipei, Taiwan), aged 21 - 48 years. The NHB players trained two times a day, 15 h (11 sessions) per week in the last 4 years. The IHB subjects trained 5 times a week (3 sport-specific and 2 fitness trainings) for the last 5 years. Basic data of players and their training experience are presented in Table 1.

Medical histories of the hearing status of subjects from the IHB group were assessed from questionnaire interviews. All those subjects were afflicted by hearing loss exceeding 80 dB (deep deafness) either inherited ( $n = 7$ ) or congenital ( $n = 6$ ). Apart from that, upon a detailed medical examination they were found to have excellent health without cardiovascular, respiratory or other disorders. All subjects gave their informed consents to participate

after having been informed about the study protocol and details, and were familiarised with the procedures. The study was approved by the local Ethics Committee.

*Methodology:* The athletes were subjected to procedures included in the Faculty of Sport and Physical Education (FSPE1) protocol: first, ventilatory and metabolic indices were measured at rest for one minute, then for another minute on a treadmill at a speed of 3 km/h; then, starting at 7 km/h, the workloads incremented progressively at a rate of 0.5 km/h every 30 s until exhaustion. The inclination was equal to 2% throughout the test. The test was considered completed when the oxygen uptake reached plateau, and the respiratory and ventilatory quotients reached reference values, the perceived state of each participant being monitored throughout the test. That latter was attained using a modified Borg's Scale (rating perceived exertion; RPE), ranging from 0 (extremely easy) to 13 (extremely hard - impossible to continue).

The following variables were recorded: maximal heart rate (HR<sub>max</sub>), oxygen pulse (V<sub>O<sub>2</sub></sub>/HR), HR at 12 km/h, HR in the 1<sup>st</sup> minute of recovery, maximal oxygen uptake (V<sub>O<sub>2</sub></sub><sub>max</sub>; ml/min), relative V<sub>O<sub>2</sub></sub><sub>max</sub> (ml/min/kg), maximal exercise ventilation (VE), tidal volume (VT), speed at V<sub>O<sub>2</sub></sub><sub>max</sub> (km/h), maximal speed attained in the test (Speed<sub>max</sub>, km/h). Treadmill T-170 (COSMED, Italy) and a breath-by-breath gas analyser (CPET, Italy). The expiratory airflow was measured by gas turbine with a mask; oxygen and CO<sub>2</sub> were determined in expired air, the latter by infrared gauge. Before each test, the volume was calibrated by 5 inspiratory and expiratory strokes at different flows with a 3-1 pump; the gas analyser was calibrated with two gas mixtures of known oxygen and CO<sub>2</sub> concentrations (20.9% O<sub>2</sub>, 0.03% CO<sub>2</sub> and 16.0% O<sub>2</sub>, 5.0% CO<sub>2</sub>, respectively).

*Data analysis:* Student's *t*-test for independent data was used to assess the between-group differences. The level of  $p < 0.05$  was considered significant.

### 3. Results and discussion

Mean values ( $\pm$ SD) of basic somatic data and training experience of handball players are presented in Table 1 and the recorded functional variables in Table 2.

**Table 1.** Mean values ( $\pm$ SD) of basic somatic variables determined in handball players with hearing impairment (IHB) and in healthy ones (NHB)

Variable	IHB	NHB
	(n=13)	(n=15)
Age (years)	30.4 + 9.1	26.2 $\pm$ 3.6
Body height (cm)	187.6 $\pm$ 7.5	188.8 $\pm$ 7.6
Body mass (kg)	87.1 $\pm$ 10.4	94.5 $\pm$ 10.7
Training experience (years)	13.1 $\pm$ 2.6*	10.3 $\pm$ 4.1

\* Significantly ( $p < 0.05$ ) different from the NHB group

**Table 2.** Mean values ( $\pm$ SD) of functional variables determined in handball players with hearing impairment

Variable	(IHB) and in healthy ones	(NHB)
	IHB	NHB
	(n=13)	(n=15)
	185.2 $\pm$ 12.6	189.7 $\pm$ 7.7
$VO_2/HR$ (1/bpm)	22.1 $\pm$ 3.5*	25.0 + 3.8
$HR_{12km/h}$ (bpm)	173.1 $\pm$ 12.3	167.5 $\pm$ 9.3
<b>HR 1st min recovery</b> (bpm)	166.1 $\pm$ 15.7*	177.3 $\pm$ 6.9
$VO_2max$ (1/min)	4.03 $\pm$ 0.53*	4.55 $\pm$ 0.61
$VO_2max$ (ml/min/kg)	46.8 $\pm$ 6.1	48.4 + 3.2
VE (1/min)	150.3 $\pm$ 19.4*	168.3 $\pm$ 25.5
VT(1)	2.87 $\pm$ 0.57*	3.33 $\pm$ 0.61
Speed at $VO_2max$ (km/h)	14.1 $\pm$ 0.9**	16.1 $\pm$ 0.9
Speed <sub>max</sub> (km/h)	14.4 $\pm$ 1.1**	16.4 + 0.9

Significantly different from the NHB group: \*  $p < 0.05$ ; \*\*  $p < 0.01$

Handball players with impaired hearing did not differ significantly from the healthy ones in heart rate either maximal or at the speed of 12 km/h and in the relative ones  $VO_2max$ . However, their heart rate at the 1<sup>st</sup> minute of recovery was significantly ( $p < 0.05$ ) lower by about 6% than in their healthy mates. They attained also significantly lower values of oxygen pulse (by 12%), absolute  $VO_2max$ , pulmonary ventilation (by 11%), tidal volume (by 14%; all  $p < 0.05$ ),



maximal speed and speed at  $\dot{V}O_2$ max (by 12%;  $p < 0.01$ ). It should be noted that the training volume of IHB subjects was much lower than that of their NHB mates (7.5 and 15 h per week, respectively).

Handball represents a strenuous contact sport that requires both anaerobic and aerobic capacities. Although anaerobic capacity is essential in handball, a high aerobic capacity can improve the rate of recovery during a game and to endure its intensity and duration [11,18]. In a competitive handball match, the heart rate usually ranges from 168 to 198 bpm [6] and may average 85% of peak HR throughout one-hour play and exceeds 80% of peak HR in about 70% of match time [15]. Both groups of subjects in this research had relatively high HRmax values recorded in the treadmill test until exhaustion. This suggests that handball activity appears to be appropriate for shaping and maintaining cardio-respiratory fitness. That latter was higher in the NHB players as reflected by their high oxygen pulse which is indicative of a high cardiac output and, thus, high oxygen supply to working muscles [19]. Lower values of aerobic capacity indices noted in players with impaired hearing, compared with their healthy mates, could be attributed to lower training loads (mainly training volume) of the former, despite their higher sport level (international vs. national leagues). On the other hand, IHB players seemed to have a more efficient adaptability to workloads as reflected by their faster decrease in HR one minute post-exercise compared with the NHB group.

The aerobic system contributes to the players ability to sustain maximal effort throughout the match and to recover faster during the short periods of lower intensity or rest [18]. The presented results suggest that NHB players had a higher aerobic potential compared to the IHB group, as reflected by pulmonary ventilation and tidal volume values, the key indices of the overall aerobic capacity. They also attained higher ( $p < 0.01$ ) speed, either maximum or at  $\dot{V}O_2$ max which was most likely due to the running technique., represents Running economy is one of the important factors of success in handball, an intermittent activity sport [4,5], which requires from the athletes to execute short bursts of effort and then to be able to recover by getting oxygen back into the system.

Summing up, shaping aerobic, as well as anaerobic mechanisms is indispensable for a high performance in handball. The presented results for handball players with hearing impairment were, generally, lower than in the healthy ones which could be attributed to a lower training volume of the former. Yet, the impaired players showed a faster recovery of heart rate

following maximal tests. Further research should be conducted to compare the hearing-impaired handball players with their mates practicing other sports or with the untrained ones. In addition, due to lower running economy of IHB subjects and considering its improvement it is necessary to modify the training protocol by adding it is necessary to improve basic technique by adding more technical sessions per week.

#### 4. Conclusions

This research deals with the determination of the capacity of handball players impairment using two groups: healthy national handball players (NHB;n=15) aged 18-33 years and international handball players with hearing impairment (IHB;= 13), winners of European Deaf-Mute Championships in 2008 (Belgrade, Serbia) and second place in Deaflympic games in 2009 (Taipei, Taiwan), aged 21-48 years. Cosmed T-170 treadmill (FSPE1 protocol) and a breath-by-breath gas analyser were used to determine the following indices of aerobic capacity: maximal heart rate (HRmax),  $VO_2$ max, oxygen pulse, lung ventilation, tidal volume, maximum speed. results: Players from the IHB group attained significantly ( $p < 0.05 - 0.01$ ) lower values of oxygen pulse and maximum speed (by 12%), heart rate 1 min post-exercise (by 6%), lung ventilation (by 11%) and tidal volume (by 14%) compared with NHB group. IHB players had also twice lower weekly training volume. On the other hand no significant between-group difference was found for the relative  $VO_2$ max. Conclusion: The lower results attained by handball players with impaired hearing compared with the healthy ones could be attributed to lower training volume per week. Thus, an increase in the training volume for the disabled players would be recommendable

#### 5. References

1. Arunovic D., Z Panteli6 (1997) Comparative analysis of the physical development and abilities of pupils with damaged and pupils with normal sense of hearing. *Phys.Ed.* 1:29-36.
2. Astrand I. (1960) Aerobic work capacity in men and women with special reference to age. *A.Physiol.Scand.* 49:169.
3. Belman J., A.Gaesser (1988) Ventilatory muscle training in the elderly. *J.Appl. Physiol.* 65:899-905.

4. Billat V.L., J.P.Koralsztein (1996) Significance of the velocity at  $\dot{V}O_{2\max}$  and time to exhaustion at this velocity. *Sports Med.* 22(2):90-108.
5. Billat V.L., R.H.Morton, N.Blondel, S.Berthoin, V.Bocquet, J.P.Koralsztein, T.P.Barstow (2000) Oxygen kinetics and modelling of time to exhaustion whilst running at various velocities at maximal oxygen uptake. *Eur. J.Appl.Physiol.* 82:178-187.
6. Boraczynski T., J.Umiaz (2008) Changes in aerobic and anaerobic power indices in elite handball players following a 4-week general fitness mesocycle. *J.Hum.Kinet.* 19:131-139.
7. Bosquet L. (2002) Methods to determine aerobic endurance. *Sports Med.* 32(11):32-36.
8. Butterfield S.A. (1987) The influence of age, sex, hearing loss, etiology and balance ability on fundamental motor skills of deaf children. In: M.Berridge, G.Wards (eds). *International Perspectives in Adapted Physical Activity*. Human Kinetics, Champaign IL, pp. 43-51.
9. Craft D.H. (2000) Visual impairments and deafness. In: *Adapted Physical Education and Sport* (3<sup>rd</sup> ed.) Human Kinetics, Champaign IL, pp. 159-180.
10. Dafoe W. (2007) Principles of exercise testing and interpretation. *Can. J Cardiol.* 23:274.
11. Delamarche P., A.Gratas, J.Beillot, LDassonville, P.Roch-congar, Y.Lessard (1987) Extent of lactic anaerobic metabolism in handballers. *Int.J.Sports Med.* 8:55-59.
12. Gorostiaga E., C.Granados, J.Ibafiez, J.Gonzalez-Badillo, M.Izquierdo (2006) Effects of an entire season on physical fitness changes in elite male handball players. *Med.Sci.Sports Exerc.* 38:357-366.
13. Heyward V. (1998) Table Reference: The Physical Fitness Specialist Certification Manual. In: *Advanced Fitness Assessment & Exercise Prescription* (3<sup>rd</sup> ed. revised 1997). The Cooper Institute for Aerobics Research, Dallas TX, p. 48.
14. Leith E., M.Bradley (1976) Ventilatory muscle strength and endurance training. *J.Appl.Physiol.* 41:508-516.
15. Loftin M., P.Anderson, L.Lytton, P.Pittman, B.Warren (1996) Heart rate response during handball singles match-play and selected physical fitness components of experienced male handball players. *J.Sports Med.Phys.Fitn.* 36:95-99.

16. Nikolai I., E.Volkov, A.Shirkovets, V.E.Borilkevich (1974) Assessment of aerobic and anaerobic capacity of athletes in treadmill running tests. *Eur.J.Appl. Physiol.* 43:121-130.
17. Panorac N., A.Matavulj, N.Grujic (2005) Maksimalna potrosnja kiseonika ( $VO_2$ max) kao pokazatelj fizicike sposob-nosti kod sportista [Maximal oxygen uptake ( $VO_2$ max) as an index of physical fitness of athletes]. *Acta Medica Mediana* 44(4): 17-20 (In Serbian).
18. Rannou, F., J.Prioux, H.Zouhal, A.Gratas-Delamarche, P.Delamarche (2001) Physiological profile of handball players. *J.Sports Med. Phys. Fitn.* 41:349-353.
19. Trivic, T., P.Drid, S.Obadov (2009) Aerobic capacity of male judokas in comparison with university students of the Faculty of Sport and Physical Education. *Arch.Budo* 5:143-146.
20. Zebrowska A., A.Zwierzchowska, K.Gawlik (2007) The dynamics of maximal aerobic efficiency in children and adolescents with hearing and visual impairment. *J.Hum.Kinet.* 17 53-62
21. Zebrowska A., K.Gawlik, A.Zwierzchowska (2007) Spirometrie measurements and physical efficiency in children and adolescents with hearing and visual impairment. *J.Physiol. Pharmacol.* 58:847-857
22. Let's GROW-UP 2017

### Author Info

Milica Djukic: E-mail: [djukomet@yahoo.com](mailto:djukomet@yahoo.com)

## The effect of anthropological characteristics on the soldiers` efficacy in mastering the NATO obstacle polygon

Željka Saratlija<sup>1</sup>, Goran Jelaska<sup>2</sup>, Goran Kuvačić<sup>3</sup>

<sup>1</sup>MORH, 4. Division of Military Police, Knin, Croatia

<sup>2</sup>Virovitica County General Hospital, Virovitica, Croatia

<sup>3</sup>University of Split, Faculty of Kinesiology, Split, Croatia

### Abstract

*The aim of this paper was to identify the variables of the anthropological status as the predictor of successful mastering of the NATO obstacle polygon, prior to and after the application of the training micro cycle. For this purpose, a sample of 15 members of the military intelligence horn aged 22 to 27 has been used. The speed required to master the NATO polygon before and after realization of the training micro cycle which lasted for 7 days. Even though the training micro cycle had a significant impact on the results in terms of velocity, surprisingly no significant influence of the initial anthropological status on the mastering of the NATO obstacle polygon was detected, which is most probably a consequence of a highly homogeneous sample. The recommendation for the future studies of this type is to introduce some precise variables into similar sample, especially in the the field of coordination and agility, variables for assessment of the morphological status and variables for assessment of specific military attainments for which there is a reasonable assumption that are needed for successful surpassing of the NATO obstacles.*

**Keywords:** NATO obstacle polygon, military, regression analysis

### 1. Introduction

For a successful and functional implementation of required tasks each member of the elite military, troops should have highly developed

anthropometric characteristics; primarily basic and specific motor skills [1,2,3]. On the other hand researches clearly indicate that physical exercise can significantly influence the development and maintaining of the achieved level of certain motor skills [4,5]. During the realization of the designated goals in soldier shape the NATO obstacle polygon is frequently used. It is consisted of multiple individual tasks coordinated into a single unit. More precisely, the NATO obstacle polygon consists of twenty obstacles and it is five hundred meters long. The exercise is performed in athletic gear and in uniform with arms and equipment. Military polygons are generally constructed in such ways to best imitate the reality that soldiers can run into when performing their tasks which means that they are a simulation of real conditions that soldiers find themselves into while performing certain tasks [6,7]. From the practical point of view, the best instruments for realistic obstacle training are the standardized simulations connected in a logical sequence with properly determined intervals in between.

After the implementation of the precisely planed and programmed training units with the NATO obstacles into the system of soldier shape preparation, soldiers are generally fit out to preserve their lives and the lives of others in critical combat situations. The training of soldiers to master certain obstacles comes down to the interactive repetition of the process of acquiring certain simple or complex motor attainments. Furthermore, mastering of any obstacle requires physical effort. Consequently, training on the obstacle track can only initiate when a certain degree of physical shape is achieved. The primary goal of training in mastering the track is to develop physical shape: strength, speed, stamina, flexibility and psychological competence in terms of increasing of self-confidence [8,9]. Furthermore, the techniques of movement that probably affect the development of coordination skills are perfected. It is important to point out that the researches of the effect of anthropological characteristics on the efficacy of mastering the NATO obstacle polygon are rare. Consequently, the aim of this paper was to examine the influence of the motor- functional skills on the efficacy of mastering the NATO polygon.

## **2. Materials and methods**

### *Participants*

A sample was consisted of 15 members of the military intelligence company in Knin. Subjects were at aged from 22 to 27 years. The measurement

was conducted in the fall of 2016 in the duration of seven days on the military polygon Bralovac on the mountain Dinara.



### *Variables*



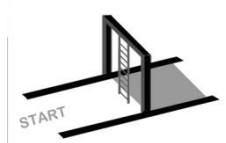

Subjects were measured in following variables: body height (ATV[cm]), body mass (ATM [kg]), the number of planks within two minutes (MPT[req]), the number of push-ups within two minutes (MSKL[req]). Lastly subjects were tested in the speed of mastering the polygon in two stages: initially and after the enforcement of the precisely structured training micro cycle.

### *Description of the NATO obstacles*



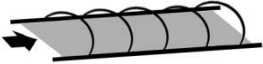
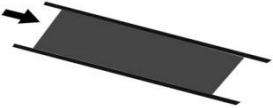
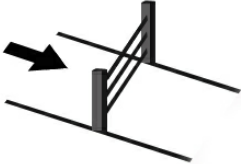

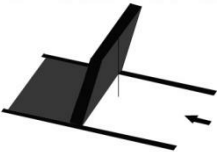
The NATO obstacle track was installed on the military polygon Bralovac on the mountain Dinara. The polygon is shaped in the letter U with assembled elements (Scheme 1).

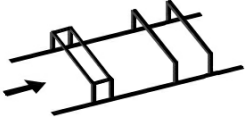

**Scheme 1.** Description of the elements of the NATO polygon

START	METERS FROM THE START	OBSTACLE
Rope ladders – made of static rope with wooden tread and fixated to the ground and to a metal hoop in the shape of football goal. It is surpassed by climbing the ladders, upon reaching the metal bar shifting to the other side and landing into a squat facing the following obstacle.	9,5	
Double beam – aligned in parallel and installed transversely to the movement direction. A soldier leaps over the first beam. Once they are in between the two beams they asses the space behind the second beam after which they leap over the second beam landing into a squat facing the following obstacle.	28	
Skipping strings - made of metal bars installed in the form of five low hurdles. The goal is to run across the obstacle in high velocity.	42	

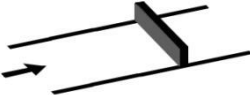
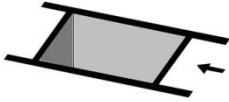
<p>Wire net—a tunnel made of a metal construction. The goal is to crawl through the tunnel without touching the metal construction.</p>	<p>62</p>	
<p>Crossing the river – an obstacle two meters in length. The goal is to leap across in a running start</p>	<p>120</p>	
<p>Brajda – a metal obstacle with three bars installed in parallel. The goal is to leap across.</p>	<p>138</p>	
<p>Balance beam – a wooden beam designed for running across (much like a gymnastic beam).</p>	<p>150</p>	
<p>A slope wall with a rope – made of concrete with a hole in behind and a rope above the hole. The goal is to grab the rope and cross the hole by swinging.</p>	<p>190</p>	
<p>Horizontal beams – metal beams installed transversely. The goal is to leap over by lifting legs laterally while holding hand crossed on the chest</p>	<p>215</p>	
<p>Irish table – a metal obstacle designed for leaping over.</p>	<p>235</p>	

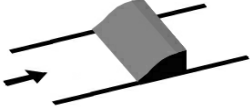
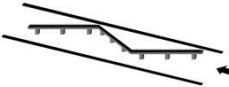

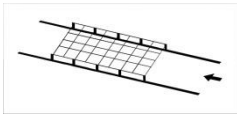
<p>Tunnel and twin beams – consists of three metal hurdles installed transversely. The goal is to pass under the first one and leap over the following two hurdles.</p>	<p>250</p>	
<p>Beam stairs – four successive hurdles increasing in height. The goal is to run across the hurdles.</p>	<p>285</p>	
<p>Dam and trench – similar to the obstacle number eight, differs in the lacking rope.</p>	<p>314</p>	
<p>Low wall – a low concrete wall designed as a cover for soldiers. As a element of the polygon it is designed for running across with the aim of increasing in speed.</p>	<p>337</p>	
<p>Pit – a hole in the ground. The goal is to jump into the hole and climb up the edge in high velocity.</p>	<p>350</p>	
<p>Vertical ladders – a metal obstacle identical in form to the obstacle number one.</p>	<p>380</p>	
<p>High wall – similar to the obstacle number fourteen; differs in height. The goal is to run to the edge and jump over.</p>	<p>390</p>	
<p>Interrupted beam – in the zigzag form, similar to the obstacle number eight; designed for running across.</p>	<p>435</p>	

Corridor – a metal construction with barriers. The goal is to run across while raising legs high (much like running across lying tires in functional training).	450	
Sequence of low walls – a sequence of three low walls, similar to obstacle number fourteen.	485	
GOAL	500	

### *Description of the procedure*

From the aspect of the Standard Operation Procedure rule book for mastering the NATO obstacle polygon with arms and equipment, it is necessary that a soldier fulfills certain conditions and standards, which were followed during this research: „A soldier is dressed in a uniform, carrying personal arms, a vest and a hat. A soldier is of good body shape and has had performed general warm up exercises prior to exercises on the track as well as successfully mastering the obstacles without the arms. Mastering of each obstacle has been demonstrated to the soldier. Each obstacle is in the sound condition and dry. The track is installed and the landing zone is prepared. The visibility is regular. A soldier consecutively surpasses obstacles in the determined order and accordingly to the transition techniques. Four primary rules are applied during soldier`s work: 1. Treat each firearm as loaded. 2. Never direct the arm into any object or person that isn`t the target. 3. Never hold the trigger unless ready to fire. 4. Be certain of the target and it`s surrounding.“ (Hkov, GMTBR ZAPOVJED-NIŠTVO, KNIN, page 24). Soldiers were exposed to measurement in surpassing the NATO obstacles in each variable initially and after the application of the training micro cycle. The training was performed in the same period each time. The approximate duration of the training was seventy minutes.

**Table 1.** Content of the applied training micro cycle.

<b>Day</b>	<b>Structure of the training</b>	<b>Intensity</b>
Mon	<p>Warm up 5 min. Running 30 min. Sprint 3x50 meters.</p> <p>1 lap: (a) push up on the ground 10,9,8,7,6,5,4,3,2,1. (b) fold 5,4,3,2,1,2,3,4,5.</p> <p>2 lap: (a) switch 20,18,16,14,12,8,6,4,2. (b) marines 1,2,3,4,5,6,7,8,9,10.</p> <p>3lap: (a) squat 20,18,16,14,12,10,8,6,4,2. (b) step out jump 2,4,6,8,10,12,14,16,18,20. Streching 10 min. Alternately performing exercises a and b. A two minute recess after each lap.</p>	Medium

Tue	Warm up 10min. Sprint 270m ; low start with changing direction  Running 3 km. 4 series of 10 marines, 20 push ups, 30 bends, 40 squats, 50 mountains, 40 step out jumps, 30 jumping jacks, 10 clapping push ups.  Alternately performing each series. A two minute recess after each series.	Moderate
Wed	Warm up 10 min. Running with stops (after each five min of exercise one min - bends, knuckle, push ups), 45 min. Sprint 4x50 meters  High and low crawling 4x100 meters. Stretching 10 min.  Recess between each discipline 2 min.	High
Thu	Recess	
Fri	Warm up 10 min. Running 4km.  Lap 1: (a) bends 10,9,8,7,6,5,4,3,2,1. (b) knuckles 1,2,3,4,5,6,7,8,9,10.  Lap 2: (a) marines 1,2,3,4,5,6,7,8,9,10. (b) Switch 20,19,18,17,16,15.  Lap 3: (a) jump squat 5x10 . (b) Clapping push up 5x10.  Stretching 10 min. Recess between each discipline 2 min. This develops stamina and repetitive strength.	High
Sat	Warm up 10 min. Commando march, 15 km, in full war equipment and personal arms. Stretching 15 min.	Extreme
Sun	Recess	

### *Methods of data interpretation*

For each variable used in the research, the parameters of the descriptive statistics were defined: arithmetic mean (AM), standard deviation (SD), minimal result (Min), maximal result (Max), variation coefficient (VC), asymmetry coefficient ( $\alpha_3$ ) and flattening coefficient ( $\alpha_4$ ). Normality of distribution was tested with Kolmogorov Smirnov test. To determine the existing relations between the variables of the anthropological status and the time used for mastering the obstacle NATO polygon, a multiple regression analysis was used in both time points. In order to identify the efficacy of the micro cycle conducted, one-way ANOVA analysis for repeated measurements was used, whereby the amount of the effect was estimated using the (partial) square quadratic coefficient ( $\eta^2$ ). For all applied statistical analysis, the error of the first type is set to  $\alpha = 5\%$ . All data is computed using statistical analysis software Statistics 12.0. (StatSoft, Tulsa, Oklahoma, USA).

### 3. Results and discussion

In table 2, descriptive statistics parameters for morphological variables and chronological age for all subjects are presented.

**Table 2:** Descriptive statistics parameters for morphological variables and chronological age for all subjects (arithmetic mean  $\pm$  standard deviation (AS  $\pm$  SD), minimum score (min), maximum score (max), coefficient of variation (CV), skewness ( $\alpha_3$ ), kurtosis ( $\alpha_4$ ) and the significance of the KS test (KS).

Variables	AS $\pm$ SD	Min	Max	CV	$\alpha_3$	$\alpha_4$	KS
ATV[cm]	189.47 $\pm$ 3.16	185.00	195.00	1.67	0.19	-0.92	p>0.20
ATT[kg]	91.47 $\pm$ 2.97	88.00	97.00	3.25	0.64	-0.95	p>0.20
MPT[req]	76.20 $\pm$ 2.14	74.00	80.00	2.81	0.75	-0.71	p>0.20
MST[req]	70.27 $\pm$ 2.71	67.00	75.00	3.86	0.47	-0.77	p>0.20
NATO-I	13.42 $\pm$ 0.24	13.00	13.73	1.77	-0.52	-0.92	p>0.20
NATO-F	11.57 $\pm$ 0.24	11.25	11.92	2.06	-0.07	-1.66	p>0.20

**Legend:** body height (ATV [cm]), body weight (ATM [kg]), number of planks in 2 minutes (MPT [frequency]), number of push-ups in 2 minutes (MSKL [frequency]). NATO and NATO-F - the speed of surpassing NATO obstacles two times: the initial and the final.

The results (Table 2) indicate the high homogeneity of the sample used. The results show that the soldiers were similar in the endurance and that their results in NATO obstacle polygon were significantly improved in the final test compared to the initial ( $F_{1,14} = 668.58$ ;  $p < 0.001$ ;  $\eta^2 = 0.979$ ). They mastered the barriers and did not have any major difficulties during the testing.

By activating muscle systems, developing abilities and acquiring tactical-technical knowledge after a micro-cycle in the duration of five days, the time required to surpass the NATO obstacles has considerably reduced. In conclusion, the training program ultimately had a positive impact on the performance itself, as well as on increasing strength, endurance, and speed. Generally, the training process leads to a higher level of fitness, improves the coordination of movement and raises the performance technique to a higher level, thus shortening the implementation time.

**Table 3:** Results of multiple regression analysis for predictor variables of anthropological status and NATO-I and NATO-F criteria ( $\beta$  - beta coefficient of regression equation,  $b$  -  $b$  coefficient of regression equation,  $p$  - significance level,  $R$  - coefficient of multiple correlation,  $R^2$  - coefficient of multiple determination).

Variables	NATO-I			NATO-F		
	$\beta$	$b$	$p$	$\beta$	$B$	$p$
ATV[cm]	-0.21	-0.02	0,73	0,17	0,01	0,78
ATT[kg]	0.02	0.00	0,97	0,05	0,00	0,94
MPT[req]	-0.14	-0.02	0,69	0,09	0,01	0,81
MST[req]	0.14	0.01	0,71	-0,01	-0,00	0,98
	R=0.38; R <sup>2</sup> =0.14 p=0.80			R=0.18; R <sup>2</sup> =0.03 p=0.99		

**Legend:** body height (ATV [cm]), body weight (ATM [kg]), number of planks in 2 minutes (MPT [frequency]), number of push-ups in 2 minutes (MSKL [req]). NATO-I and NATO-F - the speed of overcoming NATO obstacles two times: the initial and the final.

By looking at Table 3, we can conclude that, contrary to the expected, no statistically significant influence of the initial anthropological status on the performance of the NATO obstacle polygon has been identified. In addition, there are very small coefficients of multiple correlations and determinations of the used variables and criterion variables. This is probably due to the fact that a highly homogenized sample was used. Additionally, those results can be consequence of relatively small sample and the fact that only one week was observed.

#### 4. Conclusions

By observing the results of the initial and the final testing, it's evident that the microcycle of training had a significant effect on improving the results. Contrary to what was expected, the prediction of initial anthropological status was not established in the overcoming of NATO obstacles, which is probably the result of the very highly homogenized sample. In future scientific researches of this type, it is recommended that in scientific researches of similar models more anthropological variables should be included. Especially variables manifestations of coordination and agility, variables for the assessment of morphological status, and variables for the evaluation of specific military knowledge that can be reasonably assumed to significantly contribute to success the performance of NATO obstacles polygon.

## 5. References

- [1] Pihlainen, K., M. Santtila, K. Hakkinen and H. Kyrolainen. "Associations of Physical Fitness and Body Composition Characteristics with Simulated Military Task Performance." *J Strength Cond Res*, (2017), E pub Ahead of print.
- [2] Jones, B. H. and V. D. Hauschild. "Physical Training, Fitness, and Injuries: Lessons Learned from Military Studies." *J Strength Cond Res* 29 Suppl 11, (2015), pp S57-64.
- [3] Poston, W. S., C. K. Haddock, K. M. Heinrich, S. A. Jahnke, N. Jitnarin, D. B. Batchelor, Y. Feito and R. R. Suminski. "Response: Is High-Intensity Functional Training (Hift)/Crossfit Safe for Military Fitness Training?" *Mil Med* 182, no. 1 (2017) pp 1476-1479.
- [4] Sporiš, G., D. Harasin, M. Baić, T. Krističević, I. Krakan, Z. Milanović, D. Čular and L. Bagarić-Krakan. "Effects of Two Different 5 Weeks Training Programs on the Physical Fitness of Military Recruits." *Coll Antropol* 38 Suppl 2, (2014), pp 157-64.
- [5] Lee, L., S. Kumar and L. C. Leong. "The Impact of Five-Month Basic Military Training on the Body Weight and Body Fat of 197 Moderately to Severely Obese Singaporean Males Aged 17 to 19 Years." *Int J Obes Relat Metab Disord* 18, no. 2 (1994), pp 105-9.
- [6] Dimitriou, L., J. Lockey and L. Castell. "Is Baseline Aerobic Fitness Associated with Illness and Attrition Rate in Military Training?" *J R Army Med Corps* 163, no. 1 (2017), pp. 39-47.
- [7] Legg, S. J. and A. Duggan. "The Effects of Basic Training on Aerobic Fitness and Muscular Strength and Endurance of British Army Recruits." *Ergonomics* 39, no. 12 (1996), pp 1403-18.
- [8] Taylor, M. K., K. P. Sausen, E. G. Potterat, L. R. Mujica-Parodi, J. P. Reis, A. E. Markham, G. A. Padilla and D. L. Taylor. "Stressful Military Training: Endocrine Reactivity, Performance, and Psychological Impact." *Aviat Space Environ Med* 78, no. 12 (2007), pp 1143-9.
- [9] Knapik, J. J., M. A. Sharp and R. A. Steelman. "Secular Trends in the Physical Fitness of United States Army Recruits on Entry to Service, 1975-2013." *J Strength Cond Res* 31, no. 7 (2017), pp. 2030-2052.

## Author Info

Corresponding author: Goran Kuvačić, [gorkuv@kifst.hr](mailto:gorkuv@kifst.hr)

## The Effect of Specialist Military Training on Morphological Characteristics of Navy Recruits

Josip Maleš<sup>1</sup>, Toni Batinić<sup>1</sup>, Dražen Gučić<sup>1,2</sup>

<sup>1</sup>Faculty of Kinesiology University of Split

<sup>2</sup>Croatian Navy

### Abstract

A study was conducted among 199 navy recruits attending specialist military training in the Croatian Navy to determine the impact of a specially programmed military training on changes in morphological characteristics. A two-month treatment, of averagely medium intensity, abounded in contents aimed at the development of power and endurance as basic abilities necessary for recruits' efficient activity, as well as the development of specific and special skills. At the beginning and at the end of the treatment, subjects' morphological characteristics were measured by 8 standard morphological tests assessing height, mass and volume and subcutaneous fat tissue. Following the preliminary procedures of data analysis, the differences between the two measurements were determined by the paired samples T-test. The obtained results show that the specialist military training lead to positive changes in navy recruits' body build, which is generally reflected primarily in statistically significant reductions of fat tissue in the trunk and the extremities, as well as evident increase of muscle mass in the extremities, manifested in the increase of circumference and reduction of fat tissue. Finally, it should be noted that it is not possible to determine with full certainty whether the statistically significant changes in morphological characteristics of navy recruits (that occurred after the treatment and life in military regime) were minimal, optimal or maximal, given that the study did not include control groups.

**Key words:** specialist military training, navy recruits, morphology

### Introduction

Kinesiological studies often analyse the dimensions of anthropological status, whether it be their mutual correlation or the impact of one or several char-

acteristics on some performance, result, success, etc., depending, obviously, on the aim of the study itself. However, there are numerous scientific papers aimed at investigating certain anthropological characteristic or anthropological ability, or even just some manifestation which forms their integral part. One of the anthropological characteristics that always preoccupies researchers is the body build itself, i.e., morphological characteristics of separate individuals, groups or populations. Namely, morphological characteristics are important for success in kinesiological activities, and different kinesiological activities have different impact on morphological structure of the participants. Even though it is often implied due to terminology, kinesiological activities are not just sports activities, the term rather includes a vast number of human activities. These activities certainly include military training, which represents specific kinesiological engagement in which recruits are expected to possess a high level of anthropological characteristics and abilities, but also different general kinesiological and specific military skills which are at least at the stabilization level. Naturally, all skills should be at the level of automatization so that recruit can perform them flawlessly in the worst conditions possible in which he might find themselves considering their speciality. Depending on their branch of military, recruits are differentiated by their anthropological status, and therefore by their morphological build. Recruits are not differentiated only regarding their branch of military, but rather within the branches themselves, depending on the activities they perform. In short, it can be stated figuratively that each specific military training (separate kinesiological activity) is different than others to such an extent that the overall military training could be observed as a sport in general, and specific military activities as separate sports. Therefore, through the morphological subsegment, it is possible to recognize the effects of separate kinesiological activities, and military training usually leads to reduction of fat tissue and increase of active muscle mass, which has been proven by numerous studies (e.g., Vogel, Crowdy, Amor & Worsley<sup>1</sup>, 1978; Patton, Daniels & Vogel, 1980; Stacy, Hungerford & Mc Mahon, 1982; Friedl et al., 1994; Ostrunić, 1977; Maleš, Katić & Poklepović, 1997; Maleš, 1999, 2002; Maleš, Vukelić & Kosor, 2007).

Based on the aforesaid, the importance of morphological characteristics on military efficacy of recruits is evident, as well as the specific impact of each military training on body build. To contribute to and build on previous scientific findings, the main aim of this study was to determine the impact of specialist military training on changes of morphological characteristics in navy recruits.

## Methods

The subject sample included 199 male participants, recruits in the Croatian Navy, of average age of  $21 \pm 2.52$  years, without any health aberrations, capable



of fulfilling military service in the Croatian Armed Forces. The measurement was done on two occasions, 9 weeks apart. Body height and mass, voluminosity (upper arm circumference, abdominal circumference, and thigh circumference) and subcutaneous fat tissue (abdominal, thigh and calf skinfold) were assessed by applying 8 morphological measures. Between the two measurements, an experimental programme was implemented by which the participants were included in a 2-month treatment in which, apart from mastering specific motor skills, the development of functional-motor abilities was influenced, with the primary aim of developing aerobic endurance and repetitive power. The experimental programme was compound of mandatory morning drills that lasted 20 min and had 45 training units that consisted of cardio elements, strength training and stretching drills. Three times a week participants were part of 90min exercises that were performed to develop endurance, strength, overcoming obstacles, and fighting drills. Development of functional abilities was mainly achieved through the interval work of medium intensity (running, rowing, different movement forms to cover distance and overcome obstacles, carrying exercises in pairs, aerobics, etc.). Development of repetitive power was achieved by affecting all topological regions of the body, but also by applying various other operators, including operators for development of explosive power (various throws, jumps, vaults, etc.)

## Results And Discussion

**Table 1.** Descriptive statistical parameters of morphological characteristics in the 1st and the 2nd measurement and the differences between them obtained by the paired samples T-test, with the coefficient of statistical significance (p).

Variables	1st measurement		2nd measurement		Differences	
	M	SD	M	SD	T	p
Body height	182.10	± 6.83	182.16	± 6.81	0.27	0.004
Body mass	76.24	± 9.51	76.58	± 9.01	1.52	0.002
Upper arm circumference	29.84	± 2.61	30.29	± 2.42	-9.36	0.000
Abdominal circumference	85.36	± 7.29	84.42	± 6.66	7.90	0.000
Thigh circumference	55.03	± 3.88	55.26	± 3.53	-3.08	0.002
Abdominal skinfold	19.31	± 9.95	18.21	± 9.14	3.75	0.000
Thigh skinfold	14.65	± 7.40	13.73	± 6.58	7.24	0.000
Calf skinfold	12.52	± 5.10	11.86	± 4.44	7.07	0.000

Legend: M – mean; SD – standard deviation; T-test; p- significance of differences

Basic descriptive statistical parameters of recruits' morphological variables in the 1st and the 2nd measurement, and the differences between the measurements determined by the paired samples T-test are presented in Table 1. Based on the basic statistical parameters, it can be stated that the results determined in the second measurement indicate positive changes in navy recruits' body build, as compared to the first measurement. There are prominent changes in terms of decreased values of all skinfolds, especially of the abdominal skinfold, and increased measures of circumference in the extremities in the second measurement in relation to the first measurement. Lower values of standard deviation in the second measurement indicate that the results were homogenized in comparison to the first measurement. The results of the paired samples T-test show that the changes are statistically significant. Thus, it can be concluded that the specially programmed military treatment, underlain with kinesiological operators for the development of power and endurance, has led to positive changes in morphological characteristics of the recruits. Based on the obtained results, it can be stated with some certainty that a kind of "restructuring" of fat and muscle body mass occurred, and their percentage in the recruits' morphological build changed significantly. It cannot be claimed that restructuring of fat tissue into muscle tissue occurred, but it is undoubtable that the muscle mass was increased, whereas the fat mass was reduced. This is particularly evident in the extremities, whereas the lower abdominal circumference resulted from the reduction of fat tissue, which had been most prominent in this area. Almost identical information was obtained by many similar studies (e.g., Vogel et al., 1978; Patton et al., 1980; Maleš, 2002). Based on the aforementioned, it can be concluded that the applied transformation procedure produced positive and desirable changes in recruits' morphological characteristics, and it may serve as a model for planning and programming kinesiological programmes for different populations.

## Conclusion

Navy recruits in specialist training in the Croatian Navy underwent a specially programmed 2-month kinesiological treatment predominated by operators for the development of aerobic endurance and repetitive power, along with the usual contents of specialist military training. By applying the paired samples T-test, statistically significant differences were found between the first and the second measurement in all 8 applied morphological measures. By partial observation, it can be concluded that a reduction occurred in all the measures assessing fat tissue and abdominal circumference, whereas significant increase of circumference was determined in the extremities. Thus, it can be

observed that, under the influence of the treatment, a significant increase of muscle mass and a decrease of ballast mass occurred in the second measurement as compared to the first measurement, which indicates a positive effect of the overall specialist military training on morphological characteristics of navy recruits. The limitation of this study is in the fact that it did not include control groups; therefore, it cannot be determined with certainty what the real quality of the applied treatment is and whether the changes could have been greater.

### References

1. Friedl, K.E., Moore, R.J., Martinez Lopez, L.E., Vogel, J.A., Askew, E.W., Marchitelli, L.J. Hoyt, R.W., & Gordon C.C. (1994): Lower limit of body fat in healthy active men. *Journal of Applied Psychology*, 77(2), 933-940.
2. Maleš, B. (2002). *The effect of programmed kinesiological treatments on qualitative and quantitative changes in some anthropological characteristics in Croatian Army recruits*. Doctoral dissertation. Zagreb: Faculty of Kinesiology University of Zagreb, Zagreb.
3. Maleš, B. (1999). *The effect of kinesiological treatment on changes in some anthropological characteristics of members of the Croatian Army*. Master's thesis. Zagreb: Faculty of physical education, University of Zagreb, Zagreb.
4. Maleš B., Katić, R., & Poklepović, D. (1997). The effect of the specially programmed treatment for the development of aerobic endurance and repetitive strength on morphological changes. *Školski vjesnik, časopis za pedagoška i školska pitanja*. 46(2), 139-144.
5. Ostrunić, D. (1997). *Anthropometric particularities of the Croatian army recruits – reference values for assessing body development, strength and endurance*. Doctoral dissertation. Zagreb: School of Medicine, University of Zagreb.
6. Patton, J.F., Daniels, W.L., & Vogel, J.A. (1980.). Aerobic power and body fat of men and women during army basic training, *Aviation, Space and Environmental Medicine*, 51(5), 492-496.
7. Stacy, R.J., Hungerford, R.L., & Mc Mahon, B.B. (1982). The effect of basic training on aerobic capacity and body fat in New Zealand army recruits. *New Zealand Medicine Journal*, 95(772), 876-878.
8. Vogel, J.A., Crowdy, J.P., Amor, A.F., & Worsley D.E. (1978). Changes in aerobic fitness and body fat during army recruit training. *European Journal of Applied Physiology*, 40(1), 37-43.

### Author info

*josipmales94@gmail.com*

## Motor Knowledge and Process of Learning Basic Gymnastic Elements in Students of Faculty of Kinesiology

Marijo Možnik, Lucija Milčić, Kamenka Živčić Marković

Faculty of Kinesiology University of Zagreb

### Abstract

*The purpose of this study was to find out the level motor knowledge of forward and backward roll before and after the process of learning, and if there are any differences between male and female students in knowledge of basic gymnastics elements. Research was conducted on a sample of 141 2<sup>nd</sup> year students, 106 male and 35 female students, which have listened to the subject of Artistic Gymnastics, on the Faculty of Kinesiology, University of Zagreb. Examination of the elements was done by three gymnastics experts, who have evaluated forward and backward roll. Examination of the elements was conducted on the floor at the beginning of lectures of Artistic Gymnastics and after six weeks of motor learning of forward and backward roll. Students participated in the process of learning forward and backward roll, with specific methodical exercises. Statistica 12 was used for data analysis. Basic descriptive parameters, t-test for dependent samples were calculated for differences between initial and final stage of treatments and t-test for independent samples were calculated to find differences between men and women. Results of t-test for dependent samples at the level of statistical significance  $<,05$  have shown that there were difference between forward and backward roll in men and women in initial and final grades. Women had better initial and final motor knowledge than men. Results of t-test for independent samples at the level of statistical significance  $<,05$  had differences between male and female students in initial and final measurement of forward roll, there were no differences in the measurement of backward roll. This is because forward roll is a more complex element and contains more details of successful execution. This study can provide an insight into one way of learning basic gymnastic elements.*

**Keywords:** artistic gymnastics, forward roll, backward roll, students, motor knowledge, motor learning

## 1. Introduction

Artistic gymnastics is a sport branch in which aesthetically designed acyclic movement structures are evaluated according to previously prescribed convention of movement defined by rules for evaluation proposed by the International Gymnastics Organization (Živčić, 2000). Gymnastics is not only a professional sport, but also a very popular recreational activity. It is one of three basic sports and one of the most recommended sport for healthy growth and maturation, especially for children. This is the reason why gymnastics content appears in the curriculum in each year of education in primary and high schools (Vican, Milanović & Litre, 2006). Although primary and high school curriculum contains different gymnastics elements on different apparatus, inadequate school facilities are the main reason why children do not acquire full curriculum prescribed knowledge about gymnastics. However, almost every primary and high school has the adequate conditions and reconciliations for learning basic gymnastics and motor skills such as a forward roll and backward roll on the floor. Motor learning is a set of internal processes associated with practice and experience that lead to relatively permanent changes in an individual's ability in performing the motor task goal of every motor learning process (Schmidt & Lee, 2005). In artistic gymnastics, the aim of the motor learning process is to practice motor skills until perfect execution. Execution of all elements in artistic gymnastics is prescribed by the rules (FIG, 2017). Rolls are basic acrobatic elements where a performer makes a 360° rotation around the transversal axis of the body while gradually changing the support of body parts on the surface, and can be divided into forward and backward rolls (Živčić Marković & Krističević, 2016). Execution of forward roll begins from standing position with arms up, after which the gymnast squats and bends forward while placing the hands in front of the body, hips move upwards, take off is performed with both legs and chin placed on the chest, starting the rolling on the back in a tucked position, arms touching the legs, when both feet touch the floor at the same time performer stands up into a balanced position through squat. Backward roll starts from the same position as forward roll with the difference being that the performer's back is facing the direction of rolling. While going through a squat position, chin is placed on the chest, hands are placed on shoulders with palms facing upwards. Performer rolls backwards, hands are placed on the floor, and the performer stands up into a balanced position through squat. Importance of basic gymnastics elements lies in the fact that they are also utilized in other sports like swimming, diving and combat sports. Goal of application of basic

gymnastic movements is an all-round development, adoption of motion habits and improving health status; or to acquire basic motor skills and abilities which are useful in everyday life (Živčić Marković & Krističević, 2016). At Faculty of Kinesiology in Zagreb, students have artistic gymnastics as a compulsory subject on 2<sup>nd</sup> year of their study. It is divided on Artistic Gymnastics 1 in 3<sup>rd</sup> semester and Artistic Gymnastics 2 in the 4<sup>th</sup> semester. Artistic Gymnastics 1 contains most basic elements of the women's apparatus. This includes elements such as forward roll and backward roll on the floor. In Croatia, Osijek and Baranja county teachers of physical education (5th-8th grade), per grade, spent 20 hours on the gymnastic contents which corresponds to 30% of all gymnastic contents, especially elements which do not present any danger of falling or injury (forward and backward rolls, handstands and cartwheels etc.) (Badić, Živčić Marković, Sporiš, Milanović & Trajković, 2012). In Slovenia, Physical Education teachers spend 9.8 hours on gymnastics per academic year, and they mostly teach basic content like forward roll, backward roll, cartwheel, handstand, etc.), where supporting assistance is not necessary and the likelihood of falls and injuries is small (Bučar Pajek, Čuk, Kovač, & Jakše, 2010). Hours intended for learning of gymnastic content should be more numerous, especially in primary school, because it is easier to learn gymnastics elements to children when they are smaller. Živčić Marković & Čavar, (2011) conducted research on a sample of 153 students of three different generations of faculty of Kinesiology, University of Zagreb, and concluded that during the primary education, female students of the Faculty of Kinesiology did not have enough motor information about artistic gymnastics. The reason for this lies in fact that student knowledge is a good indicator about learning elements in schools, and it can be monitored if basic elements can be learned about six weeks, using simple exercises. The purpose of this study was to find out the level of motor knowledge of forward and backward roll before and after the process of learning, and if there are any differences between male and female students in knowledge of basic gymnastics elements.

## 2. Materials and methods

### *Participants*

Research was conducted on a sample of 141 2<sup>nd</sup> year students, 106 male and 35 female students who have listened to the subject Artistic Gymnastics. Examination of the elements was done by three gymnastics experts who

evaluated forward roll and backward roll. It was conducted on the floor at the beginning of the lectures of Artistic Gymnastics and after a period of six weeks of learning forward and backward roll. Students participated in the process of learning forward and backward roll, with specific methodical exercises.

### *Measurements*

Variable FORWRI is used for forward roll at the beginning of motor learning and variable FORWRF for forward roll at the end of motor learning. Variable BACWRI is used for backward roll at the beginning of motor learning and variable BACWRF for backward roll at the end of motor learning. Variable FORWRIMW is used for a forward roll at the beginning of motor learning in men and women together, variable FORWRFMW for forward roll at the end of motor learning in men and women together. Variable BACWRIMW is used for backward roll at the beginning of motor learning in men and women together and BACWRFMW is used for backward roll at the end of motor learning in men and women together. Variable FORWRIM is used for forward roll at the beginning of motor learning in men, and variable FORWRIW is used for forward roll at the beginning of motor learning in women. FORWRFM is used for forward roll at the end of motor learning in men and variable FORWRFW for forward roll at the end of motor learning in women.

### *Procedure*

On the first class of Artistic Gymnastic three gymnastics expert scored the technique of forward and backward roll with marks, on a scale from 1 to 5. Proceeding exercises for learning forward roll: 1. tucked "rocking"; 2. rolling on the back from squat to mat and back; 3. rolling on the back from squat on the floor; 4. forward roll on a slope from squat; 5. forward roll on a slope from standing (with and without assistance – for all exercises); 6. Forward roll on the floor with assistance; 7. Forward roll on the floor; 8. Forward roll on the floor over obstacles (the ball). Proceeding exercises are similar for backward roll: 1. tucked "rocking"; 2. rolling on the back from squat on the floor with placement of palms beside shoulders; 3. backward roll from squat on a slope; 4. backward roll on a slope from standing; 5. backward roll on the floor with assistance; 6. backward roll on the floor. After six weeks of learning process, experts examined execution of elements.



For forward roll grades were: 1 – forward roll finished in a sitting position, or when using hands to finish in a standing position; 2 – forward roll with placing the hands too wide, chin is not lowered on the chest, so the roll is performed on forehead, or over one shoulder; 3 – forward roll without extended knees after the take-off; 4 – good execution, but with a lack of rotation; 5 – correctly executed forward roll (Živčić Marković & Breslauer, 2011). For backward roll grades were: 1 – backward roll executed without lowering the chin on the chest; 2 – backward roll executed over one shoulder; 3 – backward roll executed with a landing on knees; 4 – good execution, but with a lack of rotation; 5 – correctly executed backward roll (Živčić Marković & Breslauer, 2011).

Statistica 12 was used for data analysis. Basic descriptive parameters and t-test for dependent samples were calculated for differences between initial and final stage of treatments and t-test for independent samples was used to find differences between men and women.

### 3. Results

**Table 1.** Descriptive indicators of forward and backward roll in men and women

Variable	Valid N	Mean	Minimum	Maximum	Std.Dev.
FORWRIMW	141	2,37	1,00	5,00	1,05
FORWRFMW	141	4,05	1,00	5,00	0,85
BACWRIMW	141	2,35	1,00	5,00	1,00
BACKWRFMW	141	4,04	2,00	5,00	0,89

K-S test has shown that data was distributed normally. Descriptive indicators of forward and backward roll in men and women together (Table 1) show us that initial grades in men and women together for forward roll (FORWRIMW) were 2,37, and 2,35 for backward roll (BACWRIMW). FORWRFMW= 4,05, final grades for forward roll in men and women, and final grades for backward roll was 4,04 (BACWRFMW).



**Table 2.** T-test for Dependent Samples in men and women with level of statistical significance of  $p < ,05$

Variable	Mean	Std. Dv.	N	Diff.	Std.Dv. Diff.	t	df	p	Confidence -95,000%	Confidence +95,000%
FORWRIMW	2,37	1,05								
FORWRFMW	4,05	0,85	141	-1,68	1,14	-17,50	140	0,00	-1,87	-1,49
BACWRIMW	2,35	1,00								
BACWRFMW	4,04	0,89	141	-1,68	1,17	-17,09	140	0,00	-1,88	-1,49

T-test for dependent samples together in men and women (Table 2) with the level of statistical significance  $p < ,05$  has shown that differences exist in men and women in initial and final measurements.

**Table 3.** Descriptive indicators of forward and backward roll in men

Variable	Valid N	Mean	Minimum	Maximum	Std.Dev.
FORWRIM	106	2,26	1,00	5,00	0,98
FORWRFM	106	3,93	1,00	5,00	0,88
BACWRIM	106	2,28	1,00	5,00	0,94
BACWRFM	106	3,98	2,00	5,00	0,89

Descriptive indicators for male students (Table 3) show that the initial grade for forward roll was 2,26 (FORWRIM), and 2,28 for backward roll (BACWRIM). Final grade for forward roll in men was 3,93 (FORWRFM), and 3,98 for backward roll (BACWRFM).

**Table 4.** T-test for Dependent Samples in men with level of statistical significance of  $p < ,05$

Variable	Mean	Std.Dv.	N	Diff.	Std.Dv. Diff.	t	df	p	Confidence -95,000%	Confidence +95,000%
FORWRIM	2,26	0,98								
FORWRFM	3,93	0,88	106	-1,68	1,20	-14,37	105	0,00	-1,91	-1,44
BACWRIM	2,28	0,94								
BACWRFM	3,98	0,89	106	-1,70	1,24	-14,16	105	0,00	-1,94	-1,46

T-test for dependent samples in men (Table 4) with the level of statistical significance  $p < ,05$  has shown that differences exist in initial and final measurements for forward and backward roll.

**Table 5.** Descriptive indicators of forward and backward roll in women

Variable	Valid N	Mean	Minimum	Maximum	Std.Dev.
FORWRIW	35	2,70	1,00	4,67	1,19
FORWRFW	35	4,40	3,00	5,00	0,65
BACWRIW	35	2,58	1,00	5,00	1,15
BACWRFW	35	4,20	2,00	5,00	0,87

Descriptive indicators for female students (Table 5) show that the initial grade for forward roll was 2,70 (FORWRIW), and 2,58 for backward roll (BACWRIW). Final grade for forward roll in women was 4,40 (FORWRFW), and 4,20 for backward roll (BACWRFW).

**Table 6.** T-test for Dependent Samples in women with level of statistical significance of  $p < ,05$

Variable	Mean	Std. Dv.	N	Diff.	Std.Dv. Diff.	t	df	p	Confidence -95,000%	Confidence +95,000%
FORWRIW	2,70	1,19								
FORWRFW	4,40	0,65	35	-1,70	0,95	-10,55	34	0,00	-2,02	-1,37
BACWRIW	2,58	1,15								
BACWRFW	4,20	0,87	35	-1,62	0,94	-10,19	34	0,00	-1,94	-1,30

T-test for dependent samples in women (Table 6) with level of statistical significance  $p < ,05$  has shown that differences exist in initial and final measurements for forward and backward roll.

**Table 7.** T-tests for independent samples between men and women in initial and final state in forward roll with level of statistical significance of  $p < ,05$

(Grouping variable: M-1 W-2 Group 1: 2 Group 2: 1)

Variable	Mean 2W	Mean 1M	t-value	df	p	Valid N 2	Valid N 1	Std.Dev. 2	Std.Dev. 1	F-ratio Variances	p Variances	Levene F(1,df)	df Levene	p Levene
FORWRI	2,70	2,26	2,22	139	0,03	35	106	1,19	0,98	1,48	0,13	6,04	139	0,02
FORWRF	4,40	3,93	2,89	139	0,00	35	106	0,65	0,88	1,81	0,05	0,58	139	0,45

T-test for independent samples between men and women (Table 7) with level of statistical significance  $p < ,05$  has shown that differences exist in initial and final grade in forward roll.

**Table 8.** T-tests for independent samples between men and women in initial and final state in backward roll with level of statistical significance of  $p < ,05$

(Grouping variable: M-1 W-2 Group 1: 2 Group 2: 1)

Variable	Mean 2W	Mean 1M	t-value	df	p	Valid N 2	Valid N 1	Std.Dev. 2	Std.Dev. 1	F-ratio Variances	p Variances	Levene F(1,df)	df Levene	p Levene
BACWRI	2,58	2,28	1,55	139	0,12	35	106	1,15	0,94	1,49	0,13	2,82	139	0,10
BACWRF	4,20	3,98	1,26	139	0,21	35	106	0,87	0,89	1,06	0,87	0,33	139	0,57

T-test for independent samples between men and women (Table 8) with level of statistical significance  $p < ,05$  has shown that there are no differences in initial and final grade in backward roll.

#### 4. Discussion and conclusion

Descriptive indicators of forward and backward roll in men and women together indicate that there was a progress in motor learning, because the initial grade was 2, and final grade was 4. Results of t-test show that initial and final grades in men and women together for forward and backward roll have significant differences. As expected, a six-week period of learning elements caused an improvement in final execution as opposed to initial one. That is a consequence of application of special proceeding exercises for forward and backward roll. A previous study has shown that students of the 2<sup>nd</sup> year on Faculty of Kinesiology in Zagreb have weak motor knowledge before the start of lectures and exercises of artistic gymnastics (Možnik, Krističević, Milčić, Živčić Marković, & Šolja, 2017). It can be seen from descriptive indicators that

in the example of 106 male students, mean grade at the initial examination for forward roll was 2,26 and 2,28 for backward roll. On final examination, mean grade for forward roll was 3,93 and 3,98 for backward roll. T-test for dependent samples has shown that although mean grades are lower when only results of male students are observed, differences between initial and final grades are still significant. T-test for dependent samples has shown that although the sample of female students is 3 times smaller than male students, and mean grades are higher when only female students are observed, differences between initial and final grades are still significant. Unlike forward roll, the differences between men and women in the initial and final state of backward roll are not significant. Backward roll is a less complex element than forward roll, because forward roll contains more details which are needed for a successful execution. This could be the reason why the differences are more pronounced in a more complex element like forward roll. Živčić Marković, Sporiš, & Čavar, (2011) state that the second-year students of Faculty of Kinesiology did not gain practical information about fundamental gymnastic movement skills during their primary school, and that their knowledge about artistic gymnastics is at an insufficient level, based on the eight fundamental gymnastic movement structures (forward roll, backward roll, right cartwheel, left cartwheel, handstand, pullover, forward walk on the balance beam and safety walk on the balance beam. This study indicates that there is no improvement in initial motor knowledge of 2<sup>nd</sup> year students at the Faculty of Kinesiology in Zagreb at the beginning of the 2<sup>nd</sup> year of study in relation to previous researches. Still, significant improvement was observed in motor knowledge of basic gymnastic elements such as forward and backward roll after the process of learning those elements.

Forward and backward roll in men and women were different in initial and final grades. Women had better initial and final motor knowledge than men. The differences between male and female students when observed as independent samples was found in the initial and final state in forward roll, while there was no differences in the backward roll. This is because forward roll is a more complex element and contains more details needed for successful execution. Level of motor knowledge of other basic gymnastic elements should be tested on the same population, to acquire an insight of proceeding exercises efficiency.

## 5. References

- [1] Badić, A., Živčić Marković, K., Sporiš, G., Milanović, Z., Trajković, N. (2012). Implementation of gymnastics contents in the classroom teaching at elementary schools of Osijek - Baranja County. *Acta kinesiologica*, 1(6): 60-65.
- [2] Bučar Pajek, M., Čuk, I., Kovač, M., & Jakše, B. (2010). Implementation of the gymnastics curriculum in the third cycle of basic school in Slovenia. *Science of Gymnastics Journal*, 2(3).
- [3] FIG (2017). 2017-2020 Code of points. Men Artistic gymnastics. Moutier: Federation International de Gymnasstique.
- [4] FIG (2017). 2017-2020 Code of points. Women Artistic gymnastics. Moutier: Federation International de Gymnasstique.
- [5] Možnik, M., Krističević, T., Milčić, L., Živčić Marković, K., Šolja, Š. (2017). The knowledge and opinion of the Faculty of Kinesiology students on artistic gymnastics. U D. Milanović, G. Sporiš, S. Šalaj, D. Škegro (Ur.), *Proceedings of 8<sup>th</sup> International scientific conference on kinesiology, Opatija, 2017* (pp. 230-232). Zagreb: Kineziološki fakultet, Sveučilište u Zagrebu.
- [6] Schmidt, R.A. & Lee, T.D. (2005). *Motor control and learning: a behavioral emphasis*. Human Kinetics.
- [7] Vican, D., & Milanović Litre, I. (2006). Nastavni plan i program za osnovnu školu. Zagreb: Ministarstvo znanosti, obrazovanja i športa, 19-22.
- [8] Živčić, K. (2000). Biomehaničko vrednovanje vježbi za izvedbu premeta naprijed. [Biomechanical evaluation exercises to perform a forward handspring. In Croatian.] (Unpublished doctoral dissertation, University of Zagreb) Zagreb: Kineziološki fakultet Sveučilišta u Zagrebu.
- [9] Živčić Marković, K., & Breslauer, N. (2011). Opis nastavnih tema i kriteriji ocjenjivanja – tjelesna i zdravstvena kultura u razrednoj nastavi [Description of curriculum subject and assessment criteria – Physical Education in Elementary School. In Croatian]. Zagreb: LIP Print.
- [10] Živčić Marković, K., Čavar, I. (2011). The differences in the motoric preknowledge of artistic gymnastics among the female students of faculty of kinesiology. U: Milanović, D., Sporiš, G. (ur.) "Integrative Power of Kinesiology" (pp. 326-329). Zagreb: University of Zagreb, Faculty of Kinesiology.
- [11] Živčić Marković, K. & Krističević, T. (2016). Osnove sportske gimnastike. [Basics of artistic gymnastics. In Croatian.] Zagreb: Kineziološki fakultet Sveučilišta u Zagrebu.

---

[12] Živčić Marković, K., Sporiš, G. and Čavar, I. (2011). Initial state of motor skills in sports gymnastics among students at Faculty of Kinesiology. *Acta Kinesiologica*. 5 (1), 67-72.

### Author info

Marijo Možnik: [marijo.moznik@kif.hr](mailto:marijo.moznik@kif.hr)

## Differences in selected motor abilities and physical characteristics among five to six year old boys and girls

Špela Bogataj, Mateja Videmšek, Maja Bučar Pajek  
University of Ljubljana Faculty of Sport

### Abstract

*The aim of this research was to analyze the differences in some motor abilities and physical characteristics among five to six year old boys and girls.*

*The following seven measurement methods have been used in the research: transferring cubes, seated forward bend, bent arm hang, sit-ups, 300m run, height and weight. With these test we wanted to measure aerobic endurance, agility, coordination, speed, flexibility, muscular endurance of upper body, muscular endurance of shoulder girdle and hands, bulkiness of the body and the length dimension of the body.*

*The sample included 110 preschool children, 59 boys and 51 girls.*

*Measured data has been processed using the statistical program SPSS. For calculating the basic statistic parameters we used descriptive statistics and for determining differences in motor skills and physical characteristics among male and female we used t-test for independent samples.*

Data analysis showed that there were no statistically significant differences among five to six year old boys and girls, *except in the 300m run test, which measure aerobic endurance.* In this test, *the boys achieved statistically significant better outcome.*

Differences between boys and girls exist in all tests. *However these differences are very small and not statistically significant.* Based on this research, *we can say that sports activity in pre-school period should be organized in the same way for both boys and girls.*

**Key words:** *Preschool children, physical education, comparison, gender differences, kindergarten.*

## 1. Introduction

The preschool period is an important period for the development of motor abilities. Experts say that whatever is missed in the early childhood is hard to compensate for in later periods. A foundation for later sports activity, skills and characteristics is built on a child's activities in the early years [2].

Movement activities are one of the primary needs of young children. Movement activities enable the child to begin perceiving and discovering their body, start developing their abilities and skills while experiencing joy, pride and developing self-confidence. With movement activities children are also gaining experience in other areas [2]. We must pay attention to each individual child, therefore we have to continuously observe and consequently adapt the physical education process. Appropriate planning and a professional approach in the educational process helps us to recognize and solve children's problems [4].

In early childhood the entire organism, especially the nerve system, is most receptive of influences from the environment. So that is why this period is the most appropriate time for developing skills and personality traits [5].

Testing preschool children is very demanding. The tests must be adapted to children's early developmental period. There is still not enough knowledge in the field of preschool motor skills development [8].

Children nowadays grow up in environments which offer them less opportunities and encouragements to fulfill their needs for movement activities and therefore all the activities they are involved in are planned [7]. Professionally planned motor activities should be based on expert's findings but unfortunately these are quite rare. With our research we tried to analyze preschool children from different points of view. Our goal was to determine whether there are statistically significant differences in motor skills and physical characteristics between 5 and 6 years old boys and girls. Our hypothesis was that five-year old and six-year old boys and girls do not differ statistically in selected motor skills and physical characteristics. The hypothesis was neglected or accepted with a 5% risk ( $P \leq 0.05$ ).

## 2. Materials and methods

### *Participants*

The study included 110 children (51 girls and 59 boys) aged 5 to 6 years (boys:  $M = 5.52$  years,  $SD = 0.72$  yrs; girls:  $M = 5.49$  years,  $SD = 0.74$  yrs) attending



sport kindergarten. Physical education teacher teaches P.E. in kindergarten 3 hours per week.

### *Instruments*

In our study, children's motor abilities were measured with five motor tasks. For the measurement of physical characteristics we used two morphological tests. The following seven measurement methods have been used in the research:

- transferring cubes
- seated forward bend
- sit-ups
- bent arm hang
- 300 meters run
- body weight
- body height

With these measurement procedures, we wanted to examine whether there are differences between boys and girls in: aerobic endurance, agility, coordination, speed, flexibility, muscular endurance of upper body, muscular endurance of shoulder girdle and hands, bulkiness of the body and the length dimension of the body.

### *Procedure*

Children were divided into mixed groups. Before the measurements children were properly warmed up and they all had appropriate sports equipment and they were all healthy on the day of testing.

Children were performing their tasks at physical education classes. Running test - 300 meters was performed outside on the athletic field, other tests were performed in the gym.

They were divided into mixed group. Every group contained approximately 25 children. During the testing there were 2 persons present for measuring as well as physical education teacher.

The measurement procedures and tests are well known to children as they do them each year. Nevertheless, prior to measuring each physical task was explained and also demonstrated.

### Statistical analysis

The results of the measurements were analyzed with the statistical program SPSS. We calculated basic descriptive parameters: arithmetic mean, minimum and maximum values, standard error and standard deviation. Gender differences were analyzed with t-test for independent samples.

### 3. Results and discussion

With 300 meters run test we measure children endurance. With endurance running we improve our aerobic power and increase movement efficiency. Individual's endurance is largely related to good functioning of cardiovascular and respiratory system and is also a prerequisite for individual's health [3]. The length of the 300 meters run test is quite long for children of these age, so some have not managed to pass the entire length running and did some walking in between.

The t-test results (Table 1) show that the difference between boys and girls in the 300-meters run is statistically significant. In this test boys have achieved a statistically significant better result than girls.

**Table 1:** Results comparison among boys and girls – variable T300m(300 meters run)

Group	Variable	N	MIN	MAX	M	SN	SD	t	Sig.
Boys	T300m	59	79	135	103,44	1,603	12,315	2,849	,005
Girls		51	89	140	108,08	2,009	14,349		

Videmšek, Karpljuk and Štihec examined gender differences on a sample of 100 children, 50 boys and 50 girls, five and a half years old (+/- 6 months). Five measurements were used in the study: standing board jump, sit-ups, walking through the hoops, running after rolling on the floor and a 300-metre run. They found a statistically significant difference between boys and girls only in 300 meters run test [8].

One of the reasons that girls have achieved lower statistically significant results in the 300-meters run is that they participate in different activities and games in the preschool period. Boys are treated as strong individuals and girls are more likely raised to be gentle and housekeeping oriented. Boys play outdoors more and more often play competitive games. Girls prefer to play indoors; their games require a lot of imagination and enable them to develop empathy and a better understanding of their surroundings [5].

The results have shown that there are no statistically significant differences between boys and girls in tests transferring cubes (Table 2), seated forward bend (Table 3), bent arm hang (Table 4), sit-ups (Table 5), body height (Table 6) and weight (Table 7).

Test transferring cubes measures agility, which is a manifestation of coordination and is associated with speed [3]. We have noticed that some children had problems with rapid acceleration after changing direction.

**Table 2:** Results comparison among boys and girls – variable TC (transferring cubes)

Group	Variable	N	MIN	MAX	M	SN	SD	t	Sig.
Boys	TC	59	11,14	20,27	14,17	,242	1,855	,845	,400
Girls		51	11,99	19	14,45	,211	1,509		

In test seated forward bent girls achieved better result than boys (Table 3). On average they were better by 1.5 cm. The exact same lowest score was achieved by both genders. A large difference is evident between highest and lowest values in both sexes. The difference between highest and lowest result is 28 cm for boys and 29 cm for girls. This is also indicated by a standard deviation, from which we can see that there is a great diversification of results within both groups. The t-test, however, showed us that the gender gap is not statistically significant.

Bučar (1996) did a study on a sample of six-year-olds and also found that girls and boys do not statistically differ in results of movable tasks that define mobility [1].

**Table 3:** Results comparison among boys and girls – variable SFB (seated forward bend)

Group	Variable	N	MIN	MAX	M	SN	SD	t	Sig.
Boys	SFB	59	32	60	46,83	,955	7,337	1,143	,256
Girls		51	32	61	48,33	,882	6,301		

In Table 4 we can see that girls, on average, are better in bent arm hang test. The big difference is noticeable in the maximum value. The best result for girls is 10 seconds better than for boys. The worst result is 0 seconds, which means that test could not be performed. This indicates weak muscle strength of shoulder ring and hands. The standard deviation shows deviations within the group. We can see that girls are less homogeneous than boys. Difference in arithmetic mean between boys and girls is 2.16 seconds. Nevertheless,

the t-test showed us that even in this test there are no statistically significant differences between girls and boys.

**Table 4:** Results comparison among boys and girls – variable BAH (bent arm hang)

Group	Variable	N	MIN	MAX	M	SN	SD	t	Sig.
Boys	BAH	59	1	26	11,78	,832	6,393	1,471	,144
Girls		51	0	36	13,94	1,254	8,956		

With the test sit-ups we measure muscular strength and endurance of the abdominal musculature. Performing this test, children must learn to deploy strength and endurance, so that they can complete the exercise. Many children begin too fast and therefore end the test before time runs out. We were interested whether there are statistically significant differences between boys and girls.

**Table 5:** Results comparison among boys and girls – variable SU (sit-ups)

Group	Variable	N	MIN	MAX	M	SN	SD	t	Sig.
Boys	SU	59	2	30	15,42	,812	6,235	1,804	,074
Girls		51	7	29	18,57	,726	5,186		

T-test showed us that there are no statistically significant differences between girls and boys in this test.

Videmšek, Štihec and Karpljuk (2008) also examined differences between boys and girls aged five to five and a half years. When analyzing results of the sit-upstest, the results were similar for boys and girls. The t-test showed that boys and girls didn't differ in this test [8].

**Table 6:** Results comparison among boys and girls – variable BH (body height)

Group	Variable	N	MIN	MAX	M	SN	SD	T	Sig.
Boys	BH	59	101	134	121,05	,881	6,768	-,491	,624
Girls		51	105	137	120,43	,894	6,388		

From the table above we can see that the results of body height test are very similar for boys and girls. On average boys are slightly higher than girls. The scattering of results is similar in both genders. With t-test we found that there are no statistically significant differences in body height between boys and girls of this age.

**Table 7:** Results comparison among boys and girls – variable BW (body weight)

Group	Variable	N	MIN	MAX	M	SN	SD	T	Sig.
Boys	BW	59	15	39	22,42	,596	4,5742	,238	,812
Girls		51	13,5	35,5	22,63	,705	5,037		

Beside body height, body weight also shows children morphological characteristics. With body weight we measure body volume. The problem in today's times is the overweight of children, due to inactive lifestyle and bad eating habits [6].

In Table 7 we can see that the lowest score belongs to girls and is 1.5 kg different from the lowest score of boys. Boys reached the highest score (39 kg), which is 3.5 kg higher than the highest score of girls. Arithmetic mean shows us that on average girls and boys achieved almost the same result. T-test shows us that there are no statistically significant gender differences in body height.

#### 4. Conclusions

Our aim of the research was to test pre-school children aged 5 to 6 years and on the basis of results determine whether there are differences between boys and girls in selected motor abilities and physical characteristics.

This research results have shown statistically significant differences between boys and girls only in the 300-meters run. This is the endurance test in which boys have achieved statistically better results than girls. In other tests the results of boys and girls are approximately equal.

Testing pre-school children is associated with many problems and perhaps this is the reason for the lack of research in this field. The lack of knowledge in this field is alarming, especially if we are aware that the children motor activities represents stimulus for their non-motoric abilities and qualities [2].

Sport activities for boys and girls should be organized for both groups of children equally. It is important for the girls to take part in different running exercises in order to increase their aerobic endurance because this is the only motor ability which differs them from boys.

With this research we contributed to the existing findings and we are one step closer to better professionally planned and conducted preschool physical education.

## 5. References

- [1] Bučar, T. (1996). Primerjavagibljivostidečkov in deklicpredšolskepopulacije. [Comparison of mobility of boys and girls in the pre-school population]. Diplomskanaloga. Ljubljana: Fakultetazašport.
- [2] Cemič, A. (1997). Motorikapredšolskegaotroka. [Motoric of preschool children]. Ljubljana: Dr. Mapet.
- [3] Costello, F. and Kreis, E. J. (1993). Sports Agility. Nashville, TN: Taylor Sports Publishing, Inc.
- [4] Curtis, A. and O'Hagan, M. (2003). Care and education in early childhood: A student's guide to theory and practice. London: Routledge Falmer.
- [5] Horvat, L. and Magajna, L. (1989). *Razvojnapsihologija*. [developmental Psychology]. Ljubljana: DržavnazaložbaSlovenije.
- [6] Pajenk, A. (2010). *Analizagibalnihsposobnostištiri do šestletnihdečkov in deklicizšportnegadruštvaSvizec*. [Differences in selected motor abilities among four to six year old boys and girls] Unpublished bachelor's thesis, Ljubljana: Fakultetazašport.
- [7] Videmšek, M. and Visinski, M. (2001). *Športnedejavnostipredšolskih otrok*. [Preschool sports activities]. Ljubljana: Fakultetazašport, Inštitutzašport.
- [8] Videmšek, M., Štihec, J. and Karpljuk, D. (2008). *Analysis of preschool physical education*. Ljubljana: Faculty of Sport.

## Author info

Špela Bogataj: [sspelabogataj@gmail.com](mailto:sspelabogataj@gmail.com)

## Psychological coping skills of student futsal players

Hrvoje Sivrić<sup>1</sup>, Boris Milavić<sup>2</sup>, Marko Erceg<sup>2</sup>

<sup>1</sup>College of Slavonski Brod

Croatian Academic Sports Federation

<sup>2</sup>Faculty of Kinesiology University of Split

### Abstract

**W**ith the aim of determining their psychological coping skills, 85 futsal players from the Croatian UniSport (Academic) First League of Futsal have been measured using the ACSI-28 questionnaire. Low levels of reliability have been determined on few questionnaire scales, but all given data has been analyzed because this kind of study on a population of student futsal players hadn't been conducted in Croatia before. Average results from scales of psychological coping skills of futsal players vary between 3.06 on 'freedom from worry' scale up to medium high 3.81 on confidence/motivation scale. Groups of players of different chronological age and various futsal playing experience differ in psychological skill significance: a group of the youngest players has the lowest expression of 'freedom from worry' characteristic ( $F=3.97$ ;  $p=0.02$ ), while a group of the oldest players has a significantly lower expression of 'coping with adversity' characteristic ( $F=3.45$ ;  $p=0.04$ ); a group of players with a playing experience only at the lowest competitive rank has a significantly lower expression of concentration characteristics ( $F=3.38$ ;  $p=0.04$ ) and 'peaking under pressure' ( $F=3.14$ ;  $p=0.05$ ) than the others; a group of players with the longest playing experience in competitive futsal has a significantly higher expression of 'goal-setting/mental preparation' characteristic ( $F=4.34$ ;  $p=0.02$ ) than other players. Given results indicate the need for conducting further research of psychological characteristics of futsal players.

**Keywords:** futsal, psychological skills, psychological state, competitive experience

### 1. Introduction

Futsal is continually growing as a sport and is becoming one of the more popular sports all over the world at many different levels including

amateur, semi – professional and professional competitions. Scientific and expert findings about the relevant factors which are significantly linked with players' efficacy are issues that many coaches and researchers have to deal with in the futsal field. By its structural complexity, futsal belongs in a group of sports with poly – structured complex motions where complex structures of moving with cyclic and acyclic characteristics dominate and they are comprised of complexes of simple and complicated motions in conditions where team members collaborate during games (Dogramaci, Watsford and Murphy, 2011; Hruškar, 2006). Running with a change of rhythm and direction, explosive starts from different positions (static and dynamic), feinting, false movements and goal kicks are features that prevail in this sport. Success in futsal is also determined by a level of efficacy in performing individual and collective tasks that repeat during the game. Although there is a significant number of scientific researches that deal with futsal issues, that number is still small in terms of the anthropologic status and especially in terms of conative features of futsal players. Yeemin, Dias and Fonseca (2016) say that there are many psychological factors that haven't been researched in futsal, such as psychological characteristics, psychological skills, mental toughness and motivation. Psychological studies in futsal can be a pointer in helping to identify psychological factors which are linked with players' performance and psychological training skills. Furthermore, Gioldasis (2016) says that there is a significant lack of research in futsal in terms of psychological parameters such as motivation, anxiety, team identity, leadership, injuries and recovery. Psychological factors are important for improving performance and athletes' personal growth. They also often differentiate successful players at the highest level from the less successful. (Krane and Williams, 2006; Morris, 2000). These findings should be taken into consideration in further research and create new knowledge that would be useful for futsal. The aim of this research was to determine whether there are differences between futsal players from Croatian First League of Futsal in several psychological coping skills given their chronological age and playing experience.

## 2. Materials and methods

*Participants* – An examinee sample consists of 85 futsal players, of average chronological age of  $23.20 \pm 2.59$ . This is the majority of the population of futsal



players from the Croatian UniSport (Academic) First League of Futsal for the 2016/2017 academic year, which consists of eight top quality futsal teams from universities and other high associate-degree colleges.

*Measurements* – Measuring psychological coping skills of examinees was conducted applying a Athletic Coping Skills Inventory–28 (i.e. ACSI–28) by Smith, Schutz, Smoll and Ptacek (1995). The questionnaire consists of 28 items and measures 7 dimensions of coping using a Likert-type scale items with five response categories: Coping with Adversity (COPE); Peaking under Pressure (PEAK); Goal-Setting & Mental Preparation (GOAL/MP); Concentration (CONC); Freedom from Worry (FREE); Confidence & Motivation (CONF/MOT); and Coachability (COACH). Results from seven scales can be summed into a general measurement of psychological coping skills. In Croatia, the questionnaire has been validated by Milavić, Grgantov and Velickovska (2013) on an examinee sample of young volleyball players, where scales had an internal consistency type of reliability (Chronbach alpha type), ranked between an unacceptable level of 0.57 for the CONC scale up to a satisfying level of 0.76 for the PEAK and GOAL/MP scales. While constructing the scales, the authors Smith, Smoll and Ptacek (1995) have determined the lowest coefficient of reliability (Chronbach alpha) of 0.62 for the CONC scale. Although it is often recommended in scientific research to use scales with an internal reliability higher than 0.70 for measuring, authors Milavić (2013), Abell, Springer and Kamata (2009) claim that in the earlier stages of research scales with lower reliability can also be used if the given results from measuring will be interpreted solely at the group level. Seeing as how this questionnaire hasn't yet been applied to an examinee sample of futsal players in Croatia, at least a partial validation of the questionnaire is necessary. The questionnaire used by Milavić, Grgantov and Velickovska (2013) has been minimally adapted for measuring futsal players and then for each statement, an agreement from three experts from football and futsal fields had been conducted.

*Procedure* – Psychological coping skills measuring using ACSI–28 has been conducted by a group examining before playing the first game in the Croatian UniSport (Academic) First League of Futsal. Apart from measuring psychological coping skills, some other significant data has also been gathered from the examinees: players' chronological age and their competitive experience (playing experience in various levels of futsal competitions and longevity of competitive futsal playing).

*Statistical analysis* – The following features have been calculated for a partial validation of scales from the conducted ACSI–28 psychological skills questionnaire on an examinee sample of futsal players: reliability (Cronbach alpha type coefficient) and sensitivity (minimal and maximal result; symmetry coefficients of the result distributions; and Kolmogorov–Smirnov normality of the distribution test). The condensed results for all scales have been calculated by adding up all the items' results a scale is consisted of, and then the given number was divided by the number of items. In order to determine possible differences in psychological skills by chronological age and the experience of the players, the examinees have been distributed in groups of different age and competitive experience, and hence the differences in the level of expression of the psychological skills between those groups have been determined applying the one–way variance analysis (One-way ANOVA).

### 3. Results and discussion

Table 1 shows means and metric characteristics of the ACSI-28 scales. Reliability of internal consistency type scales (Cronbach alpha) are ranked between 0.45 for the FREE scale up to 0.72 for the PEAK scale. Even four out of seven scales have reliability coefficients under 0.60. As mentioned before, authors Milavić (2013) and Abell, Spring and Kamata (2009) believe it is justifiable to use lower reliability scales in the earlier stages of research or in cases of result interpretation at a group level. Since no scientific papers on this topic have been affirmed on an examinee sample of Croatian futsal players, the authors of the paper consider it justified to claim that this research is in its early stage of determining psychological characteristics of futsal players. Therefore, it has been decided that all four scales with reliability coefficients lower than 0.60 will be included in further procedures of statistical evaluation of data. Assuredly, while reviewing results from measuring psychological characteristics in these scales, it is necessary to take into account their low reliability of measuring and in doing so, and to be very mindful and careful when interpreting given findings as well. From various indices for sensitivity of scales which has been determined, it is justifiable to conclude that scales have a satisfactory level of sensitivity and therefore it is also justifiable to apply parametric statistical procedures in processing their results.

**Table 1.** Means and metric characteristics of the ACSI-28 scales

VARIABLE	M	SD	CRONBACH'S ALPHA	D * (K-S test)	MIN	MAX	SKEW	KURT
COPE	3.47	0.58	0.63	0.14	1.75	5.00	-0.28	0.55
COACH	3.71	0.64	0.58	0.10	2.25	5.00	-0.04	-0.52
CONC	3.69	0.49	0.54	0.12	2.00	4.75	-0.26	0.62
CONF/MOT	3.81	0.60	0.58	0.10	2.50	5.00	-0.17	-0.63
GOAL/MP	3.24	0.69	0.69	0.11	1.75	4.75	-0.07	-0.61
PEAK	3.56	0.65	0.72	0.20*	2.00	5.00	0.25	0.07
FREE	3.06	0.61	0.45	0.11	1.50	4.50	-0.03	-0.07

M – mean; SD – standard deviation; CRONBACH'S ALPHA – coefficient of internal consistency; D (K-S test) – coefficient of the Kolmogorov-Smirnov test; \* - statistical significance of the K-S test coefficient; MIN – minimum result; MAX – maximum result; SKEW – measure of distribution asymmetry, skewness; KURT – measure of distribution shape, kurtosis.

Arithmetic means determined on scales of psychological coping skills in this subject sample vary between the average 3.06 for FREE measure up to medium high 3.81 for CONF/MOT measure. Given results show how futsal players who participated in the Croatian UniSport (Academic) First league of Futsal's competition have the most difficulty with controlling their situational anxiety. Furthermore, average results from two more scales are lower than levels of 3.50 (3.24 for the GOAL/MP; 3.47 for the COPE ) which shows how futsal players are relatively unfamiliar and rarely use goal setting techniques or regulating their psychological states, and their coping with difficulties while playing is relatively unsatisfactory. They lack the ability to remain positive and enthusiastic and to stay calm and controlled even when things are going badly, or they are also not able to bounce back quickly from mistakes and setbacks.

**Table 2.** Differences of the ACSI-28 results according to the age of the examinees

VARIABLE	Age of the examinees (years)						F	P=
	19 – 21 (N=25)		22 – 24 (N=39)		25 and more (N=20)			
	M	SD	M	SD	M	SD		
COPE	3.58	0.64	3.56	0.46	3.19	0.65	3.45*	0.04
COACH	3.75	0.61	3.79	0.65	3.52	0.66	1.18	0.31
CONC	3.63	0.58	3.77	0.40	3.60	0.55	1.01	0.37
CONF/MOT	3.77	0.72	3.89	0.51	3.68	0.60	0.91	0.40
GOAL/MP	3.30	0.87	3.20	0.59	3.25	0.66	0.16	0.85
PEAK	3.43	0.65	3.71	0.61	3.46	0.69	1.74	0.18
FREE	2.79	0.47	3.22	0.67	3.09	0.56	3.97*	0.02

M – mean; SD – standard deviation; F – coefficient of the One-way ANOVA; \* – statistical significance of the coefficient; p – level of statistical significance.

It is established that there are two significant differences in measurements of psychological coping skills between groups of futsal players of different chronological age, for the FREE (situational anxiety) and COPE variables. Fisher's 'least significant difference' (LSD) test of precise differences determining between particular groups was applied post-hoc to the results of measurements from these two variables. First, it is determined that a group of the youngest players (chronological age 19 – 21) has a significantly lower FREE feature (means higher situational anxiety) than the other two groups of chronologically older players. This shows how they put additional pressure on themselves during matches, they worry about their performance (what kind and how many mistakes they will make, and how others perceive those mistakes). This difference can be justifiably explained with the fact that they are mostly freshmen's in their teams so they are probably making an effort to play well and to justify their presence in the team. This can be done mostly by not making crucial mistakes that could 'damage' the team's achievement. So they are more focused on things they don't want to happen during games and their possible mistakes. Secondly, it is determined that a group of the oldest players (chronological age 25 and older) has a significantly lower COPE feature in regard to the other two groups of younger players. It is possible that due to their chronological age they are most often senior players within their teams, so their personal and team's expectation of sport achievement are higher, which can present added difficulty exactly in the COPE during games. Therefore, in regard to other futsal players they don't remain so positive and enthusiastic when things are going badly; they are not able to bounce back quickly from mistakes and setbacks; and they don't remain calm and controlled in crucial and deciding moments of the game.

**Table 3.** Differences of the ACSI-28 results according to the playing experience – highest level of the league playing

VARIABLE	Highest level of the league playing						F	P=
	1. national league (highest rank) (N=25)		2. national league (middle rank) (N=18)		3. regional league (lowest rank) (N=20)			
	M	SD	M	SD	M	SD		
COPE	3.34	0.66	3.49	0.52	3.45	0.65	0.33	0.72
COACH	3.80	0.61	3.68	0.69	3.56	0.73	0.69	0.50
CONC	3.68	0.44	3.92	0.46	3.49	0.61	3.38*	0.04
CONF/MOT	3.88	0.67	3.76	0.60	3.64	0.63	0.81	0.45
GOAL/MP	3.25	0.68	3.21	0.71	3.27	0.73	0.04	0.96
PEAK	3.72	0.72	3.71	0.68	3.26	0.59	3.14*	0.05
FREE	3.18	0.64	3.03	0.62	2.89	0.54	1.30	0.28

M – mean; SD – standard deviation; F – coefficient of the One way ANOVA; \* – statistical significance of the coefficient; p – level of statistical significance

Table 3 shows differences of the ACSI-28 results according to the playing experience – highest level of the league playing. This analysis includes only those players that had previous competitive playing experience in some of the competing clubs of the three Croatian Leagues of Futsal. It is determined that there are two significant differences in measurements of psychological coping skills between groups of futsal players with different experiences in levels of futsal competitions, for the CONC and PEAK variables. In both cases, a group of players with the experience of playing only at the lowest competitive rank (3rd regional league), unlike those that have played at the 1st or 2nd national level of futsal competitions, has a significantly lowest level of concentration (CONC) and the lowest level of successful playing under pressure (PEAK). Unlike players that play at the highest quality level of playing (1st and 2nd national futsal league), these players have a tendency to be slightly distracted and have problems with focusing on the task at hand. Also, they perceive situations under pressure that often occur during games as threatening and then make mistakes more often than other players would in those situations. It is possible that exactly this low level of these two psychological coping skills ‘limits’ players with playing experience only to a 3rd level of the regional league in accomplishing their higher personal sports achievements. Also, we can justifiably assume that coaches who choose players for their teams for playing in leagues at a national level (1<sup>st</sup> and 2<sup>nd</sup> futsal league), choose only those that are efficient on the court, and therefore they ‘conduct’ a partial selection according to those psychological characteristics and coping skills that are necessary and linked to a higher individual competitive achievement.

**Table 4.** Differences of the ACSI-28 results according to the playing experience – years of futsal competitive experience

VARIABLE	Years of competitive experience						F	P=
	0 (N=18)		1 – 2 (N=38)		3 and more (N=25)			
	M	SD	M	SD	M	SD		
COPE	3.72	0.43	3.42	0.57	3.41	0.68	1.94	0.15
COACH	3.88	0.54	3.76	0.57	3.59	0.80	1.08	0.35
CONC	3.72	0.40	3.70	0.53	3.67	0.54	0.06	0.94
CONF/MOT	3.90	0.51	3.72	0.63	3.84	0.65	0.60	0.55
GOAL/MP	3.15	0.73	3.05	0.70	3.55	0.58	4.34*	0.02
PEAK	3.56	0.55	3.55	0.66	3.61	0.75	0.07	0.93
FREE	3.15	0.68	3.05	0.63	3.03	0.59	0.22	0.80

M – mean; SD – standard deviation; F – coefficient of the One-way ANOVA; \* – statistical significance of the coefficient; p – level of statistical significance.

This analysis included all the players that had at least a year or more previous futsal competitive experience, regardless of their level of playing in any of the existing Croatian futsal leagues. One significant difference in measurements of psychological coping skills has been determined between groups of futsal players with different longevity of futsal competitive experience, for the GOAL/MP variable. A group of players that have the longest competitive experience differs from the other two groups with shorter competitive experience in knowing and using aim setting techniques and mental preparedness techniques. It is justifiable to assume that competitive futsal playing often puts futsal players in situations that require additional regulations and/or adaptations of their personal psychological states. Then they probably search for possible solutions to these situations, whether from coaches or other more experienced players, or some outside sources. However, this finding indicates that this process of adaptation and acquiring of techniques takes sometimes even years to achieve, in order for players to be able to regulate their psychological state at a higher quality level unlike the ones in their 'rookie' stage.

When reviewing all the findings from this research as a whole, it is very interesting and notable how there are determined partial differences in the expressed psychological features between different groups of players, for each of the three different 'criterion' variables related to futsal playing. However, for each particular 'criterion' there were determined differences in other psychological coping skills: first, for groups of players of different chronological age they are FREE (situational anxiety) and COPE variables; second, for groups of players with different playing experience in levels of futsal competitions they are CONC and PEAK variables; and third, for groups of subjects with different longevity of competitive experience it is the GOAL/MP variable. The two remaining measurements of psychological skills for which no differences have been determined for none of the total three grouping and 'criterion' variables are confidence/motivation (CONF/MOT) and coachability (COACH). These two variables are stable and independent of chronological age and of playing experience of the student futsal players. It is justifiable to assume that general style and various behaviors that players adopted earlier in their development as players, is related to confidence/motivation and coachability skills and they therefore become stable at a younger age. Finally, authors of this paper are completely aware that all aforementioned needs to be taken into consideration and to have in mind that these results were established

using several measurements of psychological skills (four of seven scales) for which no sufficient level of measuring reliability has been determined, though Vaughn, Lee and Kamata (2012) state that more reliable measurements don't necessarily mean they are more valid. Thus, authors recommend to repeat the research of psychological coping skills of futsal players on another subject sample which would be more homogeneous in its playing skills and competitive experience (e.g. only futsal players from the 1st and the 2nd national league). Secondly, Milavić's claims (2013) should be taken into consideration. He recommends that for validating measuring instrument on a new examinee sample, a few new items (which would supposedly measure same constructs) should be added which means it would be possible to try 'improving' of same measuring characteristics of the validated instrument in the case of determining insufficient levels of measuring characteristics of homogeneity or reliability.

#### 4. Conclusions

This first study of psychological coping skills on an examinee sample of futsal players in Croatia has determined insufficient measuring characteristics of psychological coping skills scales of the ACSI-28 questionnaire, which is often used in scientific literature and its validation has been confirmed multiple times. And beside limitations that derive from measuring, partial differences in psychological coping skills between groups of players of various chronological ages and playing experience have been affirmed. In general, affirmed psychological coping skills of futsal players indicate the need for additional education of futsal coaches, but also players in areas of different mental preparedness techniques and psychological state regulation techniques. And finally, all this indicates an emphasized need for conducting further research on different and in particular specific sport characteristics, more homogeneous examinee sample of futsal players.

#### 5. References

- [1] Abell N., Springer D., & Kamata A. (2009). *Developing and Validating Rapid Assessment Instruments*. New York: Oxford University Press Inc.
- [2] Dogramaci, S. N., Watsford, M. L., & Murphy, A. J. (2011). Time-motion analysis of international and national level futsal. *The Journal of Strength & Conditioning Research*, 25(3), 646-651.

- [3] Gioldasis, A. (2016). A Review of Anthropometrical, Physiological, Psychological and Training Parameters of Futsal. *International Journal of Science Culture and Sport*, 4(3), 240-259.
- [4] Hruškar, S. (2006). *Condition preparation in futsal* [In Croatian]. Zagreb: Kineziološki fakultet.
- [5] Krane, V., & Williams, J. M. (2006). Psychological characteristics of peak performance. *Applied sport psychology: Personal growth to peak performance*, 5, 207-227.
- [6] Milavic B. (2013). *The psychological characteristics questionnaire for volleyball: development and validation* (Doctoral disertation) [In Croatian]. Split: University of Split, Faculty of Kinesiology.
- [7] Milavic, B., Grgantov, Z., & Velichovska, A.L. (2013). Age and positional differences in psychological coping skills of young female volleyball players. *Research in Physical Education, Sport, and Health*, 2(1), 9-16.
- [8] Morris, T. (2000). Psychological characteristics and talent identification in soccer. *Journal of Sports Sciences*, 18, 715-726.
- [9] Smith, R.E., Schultz, R.W., Smoll, F.L., & Ptacek, J.T. (1995). Development and validation of a multidimensional measure of sport specific psychological skills: The Athletic Coping Skills Inventroy-28. *Journal of Sport and Exercise Psychology*, 17, 379-398.
- [10] Vaughn B.K., Lee H.-Y., & Kamata A. (2012). Reliability. In: Tenenbaum G., R. C. Eklund, A. Kamata (eds.), *Measurement in Sport and Exercise Psychology* (pp. 25-32). Champaign, IL: Human Kinetics.
- [11] Yeemin, W., Dias, C. S., & Fonseca, A. M. (2016). A Systematic Review of Psychological Studies Applied to Futsal. *Journal of Human Kinetics*, 50(1), 247-257.

### Author info

Hrvoje Sivrić: hrvoje.sivric@vusb.hr



## Motor proficiency in the initial phase of learning rhythmic gymnastics skills

Ana Kezić, Đurđica Miletić, Nina Ivančić

*Faculty of Kinesiology University of Split*

### Abstract

*The aim of this research was to determine the influence of basic motor skills on the achieved level of specific motor skills in rhythmic gymnastics. 70 children aged 6 (30 girls and 40 boys), from two kindergartens, participated in this research. They were measured in five specific techniques of the hoop, and took a short test form of BOT-2 which measures eight motor areas: motor precision, motor integration, ambidexterity, upper-limb coordination, balance, bilateral coordination, speed and agility, as well as strength. To determine the influence of basic motor skills on the achieved level of specific motor skills of rhythmic gymnastics, we used multiple regression. The obtained results indicate a satisfactory correlation between judges in all the analysed tests for assessing the degree of skills acquisition in the initial measurement. Furthermore, the results of multiple regression analysis indicate a statistically significant effect of the basic motor skills on the degree of hoop skills which was not the case in previous researches with the rope. It is possible to conclude that the performance of different skills in the field of rhythmic gymnastics in the initial phase does not necessarily follow the same rules when it comes to different apparatus.*

**Keywords:** *fundamental motor skills, preschool children, BOT-2*

### 1. Introduction

The period of life from 2 to 7 years is described by the authors as the greatest period of development of basic motor skills (Gabbard, 2002), which can be divided into three distinctive phases: initial, elementary and mature phase of the skills development. Guided by the above division, preschool children, aged 6 and above, belong to the mature phase (Eng. Mature phase) of basic skills

development. This phase of development is characterized by the integration of all the components of the learned movement structures into a coordinated, accurate and efficient performance. Starting from this stage of development, the quality of motor performance is growing rapidly and begins to morph into the first phase of the development of specific motor skills – transitional phase (Eng. Transition phase) which is characterized by the child's increasing interest in a particular sport. Gallahue and Donnelly (2003) claim that individuals, who have not developed a mature developmental stage of basic motor skills, have limited potential for progress in acquiring specific motor skills. The question is whether this assumption is justified and reasonable when it comes to certain sports and sporting disciplines such as rhythmic gymnastics, which is the topic of this study.

From the kinesiological point of view, the most interesting fact is that, in the initial stages of learning, person creates the idea of the movement, i.e. the initial idea, and that motor structures are performed at a basic level. This phase is called the verbal-cognitive (Fitts and Posner, 1967), and it is characterized by irregularity, uncertainty, slowness and frequent errors. With time and practice, as well as with the increasing levels of motor abilities and skills, the process of removing errors ensues, and performance becomes safer and more accurate. This phase is called the associative, or motor phase of learning. Since the automation phase of learning (Schmidt and Wrisberg, 2000) requires long-lasting training and experience, it is to be assumed that the motor phase of the learning process is maintained for a long time.

The general attitude of the author is that successful mastering of basic motor skills is necessary for a successful introduction to the specific activities of a particular sport or sports activity (Burton and Miller, 1998, Gallahue and Ozmun, 1998, Jurimae and Jurimae, 2000, Karabournitios et al). However, the question is raised if this needs to be the case with the sport in which, apart from the body's technique, manipulation with different apparatus exists. Moreover, could a certain level of basic motor skills be a prerequisite for acquiring a specific knowledge in preschool children, or are children, whose basic motor skills are not at a high level, capable of adopting basic techniques of a specific sport? Finally, what motor skills are needed for success in the associative learning phase?

The main purpose of this research is to determine the influence of motor skills on the achieved level of specific motor skills of rhythmic gymnastics in the initial phase of learning.

## 2. Materials and methods

### *Participants*

The sample for this study consisted of 70 children (30 girls and 40 boys) from two kindergartens. The chronological age of children is 6 ( $\pm 6$  months), thus belonging to a group of preschool children. The study included children with no health problems and significant motor disturbances. The average height of children was  $122.4 \pm 5.0$  cm, while the average weight was  $24.49 \pm 3.78$  kg. Children could participate in sports activities beyond the experiment, except in rhythmic gymnastics. Those children who participated in the programs of rhythmic gymnastics outside the kindergarten were not involved in the research. Prior to the research, each respondent had verbally been asked about the willingness to participate, and parents had signed a formal agreement so that the child could participate in the study.

### *Measurements*

For the analysis of the level of specific rhythmic gymnastics techniques, hoop was selected as the first apparatus encountered by beginners in this sport. A selection of tests to assess the degree of the adoption of specific motor skills of rhythmic gymnastics was carried out according to the existing techniques of the hoop in such way that for each technique one test was constructed. A total of 5 tests were selected: lateral jumping in the hoop, swings of the hoop, rolling the hoop with leaps, ejecting the hoop in balance and feline jump through the hoop. For the assessment of each individual skill, a qualitative approach to grading based on an assessment of basic motor skills was used. Therefore, each test was divided into three phases (segments) of execution and each stage had to meet certain criteria. If the respondent met the criteria, one would be awarded with the grade 1, and if he did not meet the criteria, he got the grade 0. The highest possible number of points that the examinee could get on a single test is 6 because each test was repeated twice. Results in all 5 tests were summed to obtain information about the overall achieved skills of the hoop.

The "Bruininks-Oseretsky Test of Motor Proficiency", second edition (BOT-2), was selected as a tool for assessing basic motor skills. A complete form of the BOT-2 test consists of 53 separate tests, which are divided into 8 motor areas: motor precision, motor integration, ambidexterity, coordination of

hands, balance, bilateral coordination, speed and agility, as well as strength. In order to achieve a faster but effective evaluation of motor skills, a short-test form is available; it consists of 14 tests covering all 8 motor areas, and was used to analyse the motor skills of children in this research.

### *Procedure*

Through the first two weeks of the experiment, the respondents were evaluated by a test of basic motor skills. Following the testing of basic skills, the treatment began with the teachings of the specialized skills of the hoop. The treatment was performed three times a week for 35 minutes, in accordance with the plan and program for preschoolers, and the venue was the kindergarten halls. The subjects were divided into groups of 20 children and physical exercise was conducted under the guidance of the same coach. What is important about this study is only the initial measurement (recording) of the specialized skills which was conducted at the beginning of learning the same, after demonstration by the coach. Performance of the skills was recorded on video, and the assessment was later executed by three judges with the experience in judging and in accordance with clearly defined criteria of performance.

### *Statistical analysis*

Data were analysed using the Statistica for Windows 13.0 package and statistical significance was set at  $P < 0.05$ . Basic descriptive statistics were calculated for all the variables (mean values and standard deviations). For determining the reliability of the specific hoop skills, Cronbach's alpha coefficients (CA) were calculated; Kolmogorov-Smirnov test was used for determining the normality of the distribution (K-S). Finally, in accordance with the basic aim of the research – determining the influence of motor skills on the achieved level of specific motor skills of rhythmic gymnastics, multiple regression analysis was applied.

## **3. Results and discussion**

Based on the results of descriptive statistics in Table 1, it should be noted that, out of possible 30, the participants achieved the results from 0 to 21 points. Certainly, low average score (5.90) shows that the respondents still

did not have too much knowledge, as was to be expected since they didn't practice aesthetic activities. Distribution analysis result via K-S test confirms that there is no significant difference between the distribution of results and the theoretical normal distribution of results at the error of 0.05, and the resulting variable can be used in further analyses. By observing the Cronbach alpha coefficient values, ranging from 0.90 to 0.98 (with an average of 0.95) for each individual skill, we notice very high correlative values. The results indicate a satisfactory correlation between judges (particles) in all the analysed tests for assessing the degree of skills acquisition in the initial measurement.

**Table 1.** Descriptive statistics of the variables of total hoop skills in the initial measurement

INITIAL POINT OF THE LEARNING PROCESS						
	AS	SD	MIN	MAX	K-S	$\alpha$
<b>HOOP</b>	5.90	3.33	0.00	21.00	0.08	0.95

$d=0.16$  for  $N=70$  ( $p<0.05$ )

**Table 2.** Results of regression analysis between the hoop skills as criteria and motor skills as predictors in the initial measurement

HOOP	
	Beta
MP	0.10
MI	-0.05
AM	0.38
KR	0.05
RV	-0.02
BK	0.13
BA	0.22
SN	0.20
<b>R</b>	<b>0.64</b>
<b>R<sup>2</sup></b>	<b>0.41</b>
<b>p</b>	<b>0.00</b>

Legend: MP – motor precision, MI – motor integration, AM – ambidexterity, KR – hand coordination, RV – balance, BK – bilateral coordination, BA – speed and agility, SN – strength; R – Coefficient of multiple correlation, R<sup>2</sup> – coefficient of determination, p – Level of significance.

The results of multiple regression analysis in initial measurement (Table 2) indicate a statistically significant effect of the basic motor skills on the level of hoop skills ( $p=0.00$ ), while the set of predictors explained 41% of common variability. Statistically significant impact was found in one measured variable (ambidexterity  $\text{Beta}=0.38$ ). This variable is considered a predictor which indicates that subjects with above-average values on that variable also show higher level of skills with a hoop. If we define the initial point of learning as a verbal-cognitive learning phase, we conclude that, at this stage, the motor skills have a significant influence on the performance of this apparatus. Therefore, it is possible to confirm the conclusions of many authors (Burton and Miller, 1998; Gallahue and Ozmun, 1998; Jurimae and Jurimae, 2000; Karabournitios et al., 2002) about the necessity of successfully overcoming the basic motor skills for a successful introduction to specific skills. This necessity at this stage of learning has proved to be very important in the performance of skills, since the predictor set has explained a large percentage of variance criteria (41%). It is possible that the majority of the specific tests, besides the apparatus manipulation, required a certain body technique, which generated the complexity of tests; therefore, subjects with higher level of basic motor skills could easily acquire these skills. The influence of the same predictor was not found in the previously investigated skills of the rope (Kezić et al., 2013) in the initial phase, which is an indication that, for each apparatus, it is not necessary to have the same predisposition and ability. Furthermore, ambidexterity, as a skill of equalling hands left or right, proves itself to be a significant predictor of the hoop skill. The importance of ambidexterity is confirmed by the studies performed among older populations (Bozanic et al., 2008; Miletic et al., 2009; Bozanic and Miletic, 2011). However, this significant influence is also evident in the early age of the children who encounter rhythmic gymnastics for the first time. Because of the frequent switchover from one hand to the other, subjects who are equally well able to handle the prop with both hands have a better performance in the test. The verbal-cognitive phase of learning in the hoop skills mostly defines the influence of ambidexterity and the focus of subjects on apparatus manipulations. These relationships are most likely to change in the motor phase of the specific motor skills, as has been noted in the rope skills (Kezić et al., 2013); also, it will be necessary to conduct a further investigation.

#### 4. Conclusion

Previous studies have come to the conclusion that successful mastering of basic motor skills is necessary for a successful introduction to the specific

activities of a particular sport or a sporting discipline. This thesis is confirmed by this study, which dealt with the hoop skills of rhythmic gymnastics. However, the acquired result is in opposition to the data obtained by the research of the rope skills. It is possible to conclude that the performance of different aspects of skills of the rhythmic gymnastics in the initial phase does not necessarily need a high level of basic motor skills. There is a question of what happens to those relationships in the motor phase of learning, i.e. if the same motor skills are responsible for success in both the associative and the motor learning phases.

## 5. References

1. Božanić, A. & Miletić, Đ. (2011). Differences between the sexes in technical mastery of rhythmic gymnastics. *Journal of Sports Sciences*, 29(4), 337-343.
2. Božanić, A., Musa I., Zeljko I. & Rajković K. (2008). Primjena koeficijenata asimetrije u estetskim gibanjima. *Zbornik radova 3rd International Conference Contemporary Kinesiology, Mostar*, 45-49.
3. Burton, W.A. & Miller, E.D. (1998). *Movement skill assessment*. Champaign, IL: Human Kinetics.
4. Fitts, P.M. & Posner, M.I. (1967). *Human performance*. Belmont, CA: Books/Cole.
5. Gabbard, C. (2002). *Lifelong Motor Development*. Brown: Dubuque.
6. Gallahue, D. & Donnely, F. (2003). *Developmental physical education for all children*. Champaign, IL: Human Kinetics.
7. Gallahue, L.D. & Ozmun, C.J. (1998). *Understanding motor development. Infants, children, adolescents, adults*. Boston: McGraw-Hill.
8. Jürimäe, T. & Jürimäe, J. (2000). *Growth, physical activity and motor development in prepubertal children*. Boca Raton: CRC Press.
9. Karabourniotis, D., Evaggelinou, C., Tzetzis, G. & Kourtessis, T. (2002). Curriculum enrichment with self-testing activities in development of fundamental movement skills of first-grade children in Greece. *Perceptual and Motor Skills*, 94 (3), 1259-1270.
10. Kezić, A., Erceg, T. & Miletić, Đ. (2013). Specific Rhythmic Gymnastics skills acquisition conditionality in preschool children. U: *Zbornik radova 3rd International Scientific Conference Exercise and Quality of Life, Novi Sad, 2013*: 65-70.

- 
11. Miletić, Đ., Božanić, A. & Musa, I. (2009). Ambidexterity influencing performance in rhythmic composition –gender differences. *Acta Kinesiologica*, 3(1), 38-43.
  12. Schmidt, R.A. & Wrisberg, C.A. (2000). *Motor learning and performance*. Champaign, IL: Human Kinetics.

### **Author Info**

Ana Kezić, [anakezic@kifst.hr](mailto:anakezic@kifst.hr)



## Using of GPS in football training

Marko Lozančić, Tea Bešlija, Mario Tomljanović,  
Ante Jurić, Ivan Ćuković, Jakov Previšić

Faculty of Kinesiology University of Split

### Abstract

*The aim of this study is to determine correlation between internal load parameters (maximal heart rate, average heart rate) and external load parameters (total distance per minute, players load per minute, maximal speed, distance between running at different speed zones: 18-21 km/h, 21-24 km/h, over 24 km/h, exertion at the speed over 24 km/h) using Catapult GPS tracking devices and H7 heart rate monitor. By using intercorrelation analyses it was determined correlation between these variables: maximum heart rate and average heart rate and also between player load per minute and distance per minute.. This study has shown a high correlation between variables maximum heart rate and average heart rate as well as between player load per minute and distance per minute. The study also shown correlation between total distance at speed over 24 km/h and average heart rate.*

**Keywords:** GPS system, Polar, external load, internal load.

### 1. Introduction

The use of GPS over the past few years in sports has become ever greater. It is one of the biggest and most significant changes in football training from the point of view of sports science. It contributes to the dosage of athlete training, easier and more precise planning and rehabilitation. Global Positioning System (GPS) devices are navigation technology based on satellite used in professional sports over the last few years since its introduction in 1997 [10]. This technology is currently being used to provide data to sports scientists, fitness trainers, analysts and trainers in real time and after the game. The values stored in the GPS system will show the following variables: speed (m/s), acceleration/deceleration (m/s<sup>2</sup>), direction change, distance (m). These data are transmitted by the frequency measured in the hertz (Hz). So, the higher the frequency of data processing, the more information is transmitted per second, resulting in theoretically results in more accurate GPS devices. Although the

data processing frequency plays a major role in the accuracy and reliability of GPS units, and other factors have to be taken into account such as the number of available and connected satellites. That is, if we use the 10Hz satellite device, we can track the movement 10 times per second or 1 second in 1Hz model. GPS devices are often: 1Hz, 5Hz, 10Hz, 15Hz. Continuous research reveals that higher data rates are more reliable [3], meaning that 10 and 15 Hz GPS units are usually more accurate and reliable than the 1 and 5 Hz models.

### Small sided games

Using small sided games (SSG) is a recommended modality of training that promotes a significant increase in performance, the efficiency of training through a combination of technical, tactical and physical components [5]. Games (SSGs) may be insufficient to stimulate high intensity and recurring sprint requirements compared to the actual game [2] [6]. The demand for high-intensity sprinting and a large number of repetitions is associated with the game when large-sided games (LSG) are introduced [7]. This may be the result of the LSG playing in a larger space combined with the fact that players in such formations do not have so much possession of the ball [8]. In order to make the use of SSG as a fitness stimulus effect, a comprehensive understanding of related physiological and time-moving responses should be developed for all variations of the game on shortened space [7]. The aim of this study is to determine whether the above mentioned variables correlate or not. These information can help us control better the player's load in the SSG during the training session.

## 2. Methods

### Subjects

Twelve male football players aged 17-18 years (junior category according to the rules of the football game) were participating in this study. The participants are members of football club Hajduk from Split, a professional club of the Croatian First Football League. The participants were training five times per week in competition period and were playing one game on weekends.

### Sample variables

The measurement was carried out using Global Positioning System (GPS) model S5, frequency 15 HZ, manufactured by the Australian company Catapult, paired with „Polar H7 bluetooth smart“ heart rate monitor. The game took a place in a corridor measuring 50x35 meters between junior aged players, lasting 7 minutes. It was played small-sided game 6 vs 6 players plus goalkeeper.

Monitored variables for estimation of external load:

- distance covered /minute
- total load/minute
- maximum speed
- distance covered within speed zone: 18-21 km/h
- distance covered within speed zone: 21-24 km/h
- distance covered within speed zone: > 24 km/h
- number of sprints within the speed zone 21-24 km/h
- number of sprints within the speed zone > 24 km/h

Monitored variables for estimation of internal load:

- maximal heart rate
- average heart rate

### Statistical Analyses

Software "Statistica 10" was used for data processing. Modules for calculating descriptive indicators and intercorrelation matrix were used as well.

## 3. Results and discussion

**Table 1.** Basic descriptive indicators of internal and external load for monitored soccer players (N=12) in SSG

**Table 1. Descriptive statistics**

<b>Variables</b>	<b>AM</b>	<b>SD</b>	<b>Min</b>	<b>Max</b>
<b>D/min (m/min)</b>	110,42	5,38	103,00	123,00
<b>Max speed (km/h)</b>	23,50	2,54	18,00	26,00
<b>Load/min</b>	10,98	1,44	8,220	14,020
<b>Max HR</b>	189,08	10,23	178,00	209,00
<b>Avg HR</b>	168,67	11,19	159,00	190,00
<b>D 18-21km/h (m)</b>	17,67	10,45	2,00	36,00
<b>D 21-24km/h (m)</b>	8,33	7,19	0,00	21,00
<b>D &gt;24 km/h (m)</b>	4,42	6,03	0,00	20,00
<b>No. Sp. 21-24 km/h</b>	1,00	0,85	0,00	3,00
<b>No. sp &gt;24</b>	0,50	0,52	0,00	1,00

Legend:

AM- arithmetic mean

SD – standard deviation

MIN- minimum

MAX-maksimum

RD/min – running distance per minute

Max speed – maximal running speed

Load/min – load per minute

Max HR – maximal heart rate

Avg HR – average heart rate

D 18-21km/h (m) – distance covered at speed 18-21 km/h

D 21-24 km/h (m) – distance covered at speed 21-24 km/h

D >24 km/h (m) – distance covered at speed above 24 km/h

No.Sp. 21-24 km/h – number of sprints at speed 21-24km/h

No.Sp. >24km/h – number of sprints at speed above 24km/h

In Table 1 it can be noticed high range between running distance per minute considering 7 minute duration of the small-sided game. In that context, distance covered per minute can also depend on the player position (defenders compared to midfielders). By looking variables of high intensity running (18-21km/h, 21-24 km/h, >24 km/h) which also show high range of distance covered, it is visible that either particular players haven't been running in mentioned speed zones either they spent very little time in it. It can also depend on the player position in the field as well on the corridor dimensions which can bring players to inability to achieve particular speeds related to their position in the game. By looking the number of sprints (21-24km/h, >24km/h) it is visible a minimum number of high intensity sprints which can be also attributed to player position in the field and corridor dimension.

**Table 2.** Intercorrelation matrix

Variables	D/ min (m/ min)	Max speed (km/h)	Load/ min	Max HR	Avg HR	D 18-21 km/h (m)	D 21-24 km/h (m)	D >24 km/h (m)	No. Sp. 21-24 km/h	No. sp >24
D/min (m/min)	1,00									
Max speed (km/h)	0,25	1,00								
Load/min	0,69*	0,29	1,00							
Max HR	0,56	0,52	0,15	1,00						
Avg HR	0,42	0,56	0,10	0,85*	1,00					
D 18-21km/h (m)	0,27	0,30	0,33	0,11	0,11	1,00				
D 21-24km/h (m)	0,52	0,83*	0,47	0,44	0,38	0,47	1,00			
D >24 km/h (m)	0,13	0,90*	0,06	0,55	0,59*	-0,05	0,64*	1,00		
No. Sp. 21-24 km/h	0,47	0,70*	0,44	0,38	0,32	0,36	0,83*	0,51	1,00	
No. sp >24	0,19	0,88*	0,24	0,46	0,56	0,02	0,66*	0,93*	0,43	1,00

Legend:

D/min – distance covered per minute

Max speed – maximal running speed

Load/min – load per minute

Max HR – maximal heart rate

Avg HR – average heart rate

D 18-21km/h (m) – distance covered at speed 18-21 km/h

D 21-24 km/h (m) – distance covered at speed 21-24 km/h

D >24 km/h (m) – distance covered at speed above 24 km/h

No.Sp. 21-24 km/h – number of sprints at speed 21-24km/h

No.Sp. >24km/h – number of sprints at speed above 24km/h

Results indicate high correlation between distance covered per minute and load per minute. Similar results were reported by David and Julen [4]. Possible reason is the character of the game (small-sided game) and consequently decreased possibility of inactivity of players which brings them in a position of higher efficiency in every given task.

Study didn't show correlation between distance covered per minute and average heart rate. Possible reason could be inhomogeneous group because of the different player positions and physical preparedness of players. However, Casamichana reported high correlation between external load per minute and average heart rate in their study [1].

Further, this study didn't show correlation between distance covered per minute and distance covered at speeds 18-21 km/h, 21-24 km/h and over 24 km/h. Namely, players spent more time running at speeds below 18 km/h. According to Owen, in small-sided game 6 vs 6 with goalkeepers, players spent most of the time in speed zone below 18 km/h which confirms the results of this study [9].

This study also indicate high correlation between maximum running speed and distance covered at speeds 21-24 km/h and above 24 km/h as well as with the number of sprints at speeds 21-24 km/h and over 24 km/h. In order for the player to reach maximum speed in the game, he must spend particular time in speed zone under 24 km/h.

#### **4. Conclusions**

The purpose of this study was to establish the correlation between different internal and external load indicators in the shortened space. The results obtained indicate a high correlation between load per minute and measured meters per minute, which could be a good indicator of how long the game lasts and the distance covered in the shortened space. One of the problems lies in determining high intensity running in SSG because of a reduced corridor which results in insufficient retention in these zones and without GPS tracking it is not possible to clearly determine the covered distance. In order to better define training, it is necessary to take a larger number of parameters which will give you a more precise target load in training as well as better individual access to each player. It leads to faster and accurate detection and action on potential injuries. Continuous monitoring prevents the player from getting into the state of overtraining. In order to make clearer conclusions in the future, further research on this topic is needed.

## Journal Article

- [1] Casamichana, D., Castellano, J., Calleja-Gonzalez, J., San Román, J., & Castagna, C. (2013). Relationship between indicators of training load in soccer players. *The Journal of Strength & Conditioning Research*, 27(2), 369-374.
- [2] Casamichana, D., Castellano, J., & Castagna, C. (2012). Comparing the physical demands of friendly matches and small-sided games in semiprofessional soccer players. *The Journal of Strength & Conditioning Research*, 26(3), 837-843.
- [3] Cummins, C., Orr, R., O'Connor, H., & West, C. (2013). Global positioning systems (GPS) and microtechnology sensors in team sports: a systematic review. *Sports Medicine*, 43(10), 1025-1042.
- [4] David, C., & Julen, C. (2015). The relationship between intensity indicators in small-sided soccer games. *Journal of human kinetics*, 46(1), 119-128.
- [5] Dellal, A., Owen, A., Wong, D. P., Krustup, P., van Exsel, M., & Mallo, J. (2012). Technical and physical demands of small vs. large sided games in relation to playing position in elite soccer. *Human movement science*, 31(4), 957-969.
- [6] Gabbett, T. J., & Mulvey, M. J. (2008). Time-motion analysis of small-sided training games and competition in elite women soccer players. *The Journal of Strength & Conditioning Research*, 22(2), 543-552.
- [7] Hill-Haas, S. V., Dawson, B. T., Coutts, A. J., & Rowsell, G. J. (2009). Physiological responses and time-motion characteristics of various small-sided soccer games in youth players. *Journal of sports sciences*, 27(1), 1-8.
- [8] Owen, A. L., Wong, D. P., McKenna, M., & Dellal, A. (2011). Heart rate responses and technical comparison between small-vs. large-sided games in elite professional soccer. *The Journal of Strength & Conditioning Research*, 25(8), 2104-2110.
- [9] Owen, A. L., Wong, D. P., Paul, D., & Dellal, A. (2014). Physical and technical comparisons between various-sided games within professional soccer. *International journal of sports medicine*, 35(04), 286-292.
- [10] Schutz, Y., & Chambaz, A. (1997). Short Communication Could a satellite-based navigation system (GPS) be used to assess the physical activity of individuals on earth?. *European Journal of Clinical Nutrition*, 51, 338-339.

## Author Info

*Tea Bešlija, teabes@kifst.hr*

## Body Mass Manipulation in Taekwondo

Tea Bešlija<sup>1</sup>, Dražen Čular<sup>1</sup>, Daria Bilić<sup>1</sup>, Mario Tomljanović<sup>1</sup>, Nenad Stojiljković<sup>2</sup>,  
Ljubomir Pavlović<sup>2</sup>

<sup>1</sup> Faculty of Kinesiology University of Split

<sup>2</sup> University of Niš, Faculty of Sport and Physical Education

### Abstract

*The aim of study was to investigate does taekwondo athletes in Croatia reduce body mass for competition and whether exists a connection between body mass reduction and injuries in age 13-15. Data was collected by a questionnaire of 40 competitors (20 female and 20 male) all weight categories. Pearson`s coefficient correlation was used to determine correlation between variables body mass and body mass reduction for the competition and correlation inside of the groups according to degree of injury. All respondents reported that during the last week before the competition they reduced body mass at least one time in their sport career. The results showed that female athletes in average was reducing 1,75 kg, male 1kg of body mass in a week before the competition. On average, the respondents had little problems with the injuries, female slightly more than male. Obtained results showed negative correlation between variables body mass reduction and body mass ( $r=-0,47$ ) in female athletes, while in male there was no statistically significant correlation between variables. The correlation between variables body mass and body mass reduction showed only in group 1 – no injuries, however, that group makes 62,1% of the total sample. For further research it is necessary to expand the sample on other age groups.*

**Keywords:** *body reduction, competition, injury, taekwondo*

### Introduction

Athletes in martial arts often manipulate with their body mass to compete in lower weight category which could provide them better chance of success. Weight categories have the role of grouping competitors with approximately similar muscle mass and strength, and hence the impact on injury prevention

[1]. Competitors in a fast and inadequate way reduce body mass, most often at the expense of losing body fluids. This problem goes years back. Extreme reduction of food and water, use of the sauna, diuretics [2], exercising in plastic suits are common features of athletes in martial arts to reduce body weight before weighing for competition [3]. In 1997, dehydration in the range of 7 to 10% of its body mass contributed to the deaths of three student wrestlers in the United States. This helped to move the weighing time at the University at 1-2 hours before the competition. Unfortunately, this rule did not spread to the European and International Federation of any martial art, and as a consequence the reduction of body weight still dominates for weighing purpose [4]. American College of Sports Medicine has been suggesting for a long time that competitors should not lower their body weight below the weight where body fat is lower than 5% [5]. Although the minimum weight category is usually established based on body fat estimation [6] still there is a lot of space to talk about the failure of educational programs, because around third of the athletes compete below their calculated minimum weight and are still successful [7]. Today we are witnessing various way of manipulating body mass which influences the health status of athletes, especially young people. Although there is a widespread negative conotation about the effects of rapid weight loss on health status, the distrubution of agresive and harmful forms of body mass reduction is very high in most martial arts such as wrestling [9], judo [10, 11],jiujitsu, karate, taekwondo[11], boxing [12].

On this topic there are various researches worldwide, while in Croatia there are none. The aim of this study is to investigate whether taekwondo athletes in Croatia reduce body mass for competition and whether exists a connection between body mass reduction and injuries in young taekwondo athletes (age 13-15).

## Materials and methods

Data used in the research were obtained by a questionnaire of 40 competitors in taekwondo at the level of Croatia. The questionnaire was filled by 20 female and 20 male respondents born 2002.-2004. (age 13-15) about their sports career. Two female respondents did not answer on particular questions about injuries, so their results did not enter in to data processing which involve the variable „degree of severity of the injury“. Respondents are current medal holders on state championship in their categories and within their age group.



**Variables from the questionnaire used for data processing:**

Name and surname (athlete)/	Date of birth/ Gender/
Body height/	Body weight
At what age did you begin training?	How many hours per week do you train?
How many kilos you reduce before the competition (in a period of 7 days)?	Have you interrupted and continued your sports career?
If you stopped training because of the injury, how long did the break last?	If you stopped training, what was the cause of the break?
If you have been injured, have you been treated in consultation with a doctor?	Have you had any pain during your training?
Did you have any problems with injuries in your sports career (0. Other, some other cause, which; 1.I did not have any problems with injuries; 2. Overuse syndrome/tendinitis; 3. Strain; 4. Fracture)	

The results were analyzed using „Statistica 13“, the normality of distribution was evaluated using KS (Kolmogorov-Smirnov) test. All results are presented through arithmetic mean, standard deviation, median, minimum and maximum results of total sample and separated by gender. Pearson`s coefficient correlation was used to determine correlation between variables body mass and body mass reduction for the competition and correlation inside of the groups according to degree of injury.

**Results and discussion**

Female athletes on average are smaller and have fewer pounds, trained more than male per week and have less total years of training. Descriptive statistic show differences between data in total sample and sample divided by gender by reducing body mass and degree of injury. Female athletes reported

reducing body mass in average 1,75 kg, while male athletes reduced in average 1 kg. In average female athletes reported greater degree of injury (1,94) than male (Tables 1-3). In the total sample (Table 4) we can see correlation between variables „Body height“ and „body mass“ ( $r=0,79$ ), and variables „degree of injury“ and „body mass reduction“ ( $r=0,33$ ). Samples separated by gender (Table 5 and 6) show different results. Female athletes indicate negative correlation between variables „body mass reduction“ and „body mass“ ( $r=-0,47$ ), while in male cadets there is no statistically significant correlation between those variables. Correlation between variables „body weight“ and „body mass reduction“ ( $r=-0,42$ ) is shown only in group 1 – I did not have any problems with injuries (Table 7).

**Table 1.** Descriptive statistics for the total sample: N (total number), AS (arithmetic mean), MED (median), MIN (minimum result), MAX (maximum result), SD (standard deviation), KS (Kolmogorov-Smirnov test)

	N	AS	MED	MIN	MAX	SD	KS
TV	40	166,67	170,00	142,00	186,00	12,02	0,13
TM	40	53,17	51,00	40,00	76,0	11,54	0,13
UKST	40	8,95	9,00	1,00	15,00	3,14	0,13
UKGT	40	7,62	8,00	3,00	12,00	2,16	0,14
REDKG	40	1,65	1,00	1,00	3,0	0,77	0,32
OZLJ	38	1,71	1,00	0,00	4,00	1,13	0,36

TV – body height, TM – body mass, UKST – total hours of training per week, UKGT – total years of training, REDKG – body mass reduction in kilos, OZLJ – degree of injury

**Table 2.** Descriptive statistics for female athletes (age 13-15): N (total number of examinees), AM (arithmetic mean), MED (median), MIN (minimum result), MAX (maximum result), SD (standard deviation), KS (Kolmogorov-Smirnov test)

	N	AS	MED	MIN	MAX	SD	KS
TV	20	164,25	164,50	142,00	184,00	10,31	0,11
TM	20	51,05	50,00	40,00	73,00	10,48	0,16
UKST	20	9,60	9,50	5,00	15,00	2,77	0,15
UKGT	20	7,40	7,50	3,0	12,00	2,43	0,16
REDKG	20	1,75	2,00	1,0	3,00	0,71	0,26
OZLJ	18	1,94	1,50	1,00	4,00	1,16	0,29

TV – body height, TM – body mass, UKST – total hours of training per week, UKGT – total years of training, REDKG – body mass reduction in kilos, OZLJ – degree of injury

**Table 3.** Descriptive statistics for male athletes (age 13-15): N (total number of examinees), AM (arithmetic mean), MED (median), MIN (minimum result), MAX (maximum result), SD (standard deviation), KS (Kolmogorov-Smirnov test)

	N	AS	MED	MIN	MAX	SD	KS
TV	20	169,10	175,50	143,00	186,00	13,35	0,22
TM	20	55,30	54,50	40,00	76,00	12,42	0,14
UKST	20	8,30	8,50	1,00	15,00	3,42	0,16
UKGT	20	7,85	8,00	5,00	11,0	1,90	0,13
REDKG	20	1,55	1,00	1,00	3,00	0,82	0,39
OZLJ	20	1,50	1,00	0,00	4,00	1,10	0,42

TV – body height, TM – body mass, UKST – total hours of training per week, UKGT – total years of training, REDKG – body mass reduction in kilos, OZLJ – degree of injury

**Table 4.** Correlation coefficient for total sample (N = 38),  $p < 0.05$

	TV	TM	UKST	UKGT	REDKG	OZLJ
TV	1,00					
TM	0,79	1,00				
UKST	-0,15	-0,30	1,00			
UKGT	0,13	0,22	-0,30	1,00		
REDKG	-0,02	-0,21	0,12	0,02	1,00	
OZLJ	0,22	0,29	0,01	0,26	0,33	1,00

TV – body height, TM – body mass, UKST – total hours of training per week, UKGT – total years of training, REDKG – body mass reduction in kilos, OZLJ – degree of injury

**Table 5.** Correlation coefficient in female,

N=18,  $p < 0,05$  N=20,  $p < 0,05$

	TV	TM	UKST	UKGT
REDKG	-0,2	-0,47	0,15	0,01
OZLJ	0,34	0,45	-0,07	0,22

**Table 6.** Correlation coefficient in male,

	TV	TM	UKST	UKGT
REDKG	0,12	-0,006	0,06	0,05
OZLJ	0,24	0,25	0,01	0,33

TV – body height, TM – body mass, UKST – total hours of training per week, UKGT – total years of training, REDKG – body mass reduction in kilos, OZLJ – degree of injury

**Table 7.** Correlation coefficient between variables „body mass“ and „body mass reduction“ of total sample per group. Group 1 (N=23) – I did not have problems with injuries, Group 2 (N=5) – Overuse syndrome/tendinitis, Group 3 (N=4) – strain, Group 4 (N=5) –fracture;  $p < 0,05$

	GRROUP 1		GROUP 2		GROUP 3		GROUP 4	
	TM	REDKG	TM	REDKG	TM	REDKG	TM	REDKG
AS	50,17	1,52	59,20	1,40	66,25	2,00	53,00	2,20
SD	12,09	0,66	10,98	0,54	4,71	1,15	6,36	1,09
r		<b>-0,42</b>		-0,76		-0,67		0,07

AS – arithmetic mean, SD – standard deviation, TV- body height; TM- body mass, REDKG- body mass reduction

In Table 7 are results of athletes divided into groups by degree of injury. First group represent group of athletes which “did not have problems with injuries”. That group represents 62.1% of the total sample suggesting the direction in which goes body mass reduction among Croatian taekwondo competitors in cadet category. The same sample show negative correlation between variables „body mass“ and „body mass reduction“ (-0,42). Data was collected from whole sample because questionnaire was related on theirs sports career to discover is there body mass reduction between young taekwondo athletes in Croatia. Fast body mass reduction affects cognitive performance and mood [12], and those parameters are important in taekwondo because sport requires concentration, good evaluation and skill.

## Conclusions

In the world there is widespread fact that competitors reduce their body mass in inadequate way for the needs of the competition. According to the responses in the survey questionnaire, Croatian competitors, (age 13-15 years), lose weight for the needs of competition. This research showed negative correlation between variables „body mass“ and „body mass reduction“ for competiton ( $r = - 0,42$ ) of 62.1% of respondents. The same group reported that they had no problems with injuries during training status. Respondents who had experience with injuries, according to the results, did not show correlation between mentioned variables. All athletes were included in the sample because there is a questionnaire about theirs body mass reduction in theirs sports career. The aim was to determine is it body mass reduction spread in Croatian taekwondo athletes aged 13-15. For further research it

is necessary to expand the sample on other age groups in the competition systems and determine their body composition (hydration, body mass, etc.) in a period without competition and on a day of the competition in order to determine whether they are subject of body mass reduction for the needs of the competition and on which way they reduce body mass.

## References

- [1] Garcia-Pallares J., Maria Lopez Gullon J, Muriel X, et al. Physical fitness factors to predict male olympic wrestling performance. *Eur J Appl Physiol*. 2011;111:1747-58.
- [2]Tipton, C. M., &Tcheng, T. K. (1970). Iowa wrestling study: weight loss in high school students. *Jama*, 214(7), 1269-1274.]
- [4]Fernández-Elías, V. E., Martínez-Abellán, A., López-Gullón, J. M., Morán-Navarro, R., Pallarés, J. G., De la Cruz-Sánchez, E., & Mora-Rodriguez, R. (2014). Validity of hydration non-invasive indices during the weightcutting and official weigh-in for Olympic combat sports. *PLoS one*, 9(4), e95336.
- [5]Oppliger, R. A., Case, H. S., Horswill, C. A., Landry, G. L., & Shelter, A. C. (1996). American College of Sports Medicine position stand. Weight loss in wrestlers. *Medicine and science in sports and exercise*, 28(6), ix-xii.
- [6] Utter, A. C., & Lambeth, P. G. (2010). Evaluation of multifrequency bioelectrical impedance analysis in assessing body composition of wrestlers. *Med Sci Sports Exerc*, 42(361), 7.
- [7]Wroble, R. R., &Moxley, D. P. (1998). Weight loss patterns and success rates in high school wrestlers. *Medicine and science in sports and exercise*, 30(4), 625-628.
- [8] Steen, S. N., & Brownell, K. D. (1990). Patterns of weight loss and regain in wrestlers: has the tradition changed? *Medicine and science in sports and exercise*, 22(6), 762-768.
- [9]Artioli, G. G., Franchini, E., Nicastro, H., Sterkowicz, S., Solis, M. Y., &Lancha, A. H. (2010). The need of a weight management control program in judo: a proposal based on the successful case of wrestling. *Journal of the International Society of Sports Nutrition*, 7(1), 15.
- [10] Brito, C. J., Roas, A. F. C. M., Brito, I. S. S., Marins, J. C. B., Córdova, C., &Franchini, E. (2012). Methods of body-mass reduction by combat sport athletes. *International journal of sport nutrition and exercise metabolism*, 22(2), 89-97.

---

[11](Perón, A. P. O. N., ZampronaFilho, W., da Silva Garcia, L., da Silva, A. W., & Alvarez, J. F. G. (2009). Perfil nutricional de boxeadores olímpicos e avaliação do impacto da intervenção nutricional no ajuste de peso para as categorias de lutas. *Mundosaúde*, 33, 352-357.

[12] Hall, C. J., & Lane, A. M. (2001). Effects of rapid weight loss on mood and performance among amateur boxers. *British journal of sports medicine*, 35(6), 390-395.

This work has been supported by the Croatian Science Foundation, Project No. 6524

### Author Info

Tea Bešlija: [teabes@kifst.hr](mailto:teabes@kifst.hr)

## Differences in personality dimensions regarding the success in sport of the candidates for enrolment in the Faculty of Sport and Physical Education

Darinka Korovljević, Zoran Milošević, Dejan Madić, Nebojša Maksimović  
Faculty of sport and physical education, University of Novi Sad

### Abstract

*The basic goal of this research was to examine the psychological characteristics of adolescent athletes, candidates for enrolment in the Faculty of Sport and Physical Education of the University of Novi Sad, and to identify if there were and what were the differences in personality dimensions with regard to their previous success in sport. The research was conducted using the standardised questionnaire for personality dimension assessment, Big five plus two on the total sample of 121 athletes, with average age of  $18.75 \pm$ . The sample consisted of three sub-samples with regard to the achieved level of participation in sport competitions – international ( $n=48$ ), national ( $n=41$ ) and local ( $n=32$ ). The use of the analysis of variance (ANOVA) identified statistically significant differences in scores of the personality dimensions on the scale of Positive Valence ( $F=4,708$ ,  $p \leq 0,01$ ), Conscientiousness ( $F=3,556$ ,  $p \leq 0,05$ ), in favour of the athletes of international level, compared to the other two categories of athletes, while when it comes to other dimensions Neuroticism, Extraversion, Aggressiveness, Openness to Experience and Negative Valence there were no statistically significant differences. Post hoc analysis (Tukey) confirmed that within the dimensions of Conscientiousness and Positive Valence, significant differences were shown between the athletes of international and local level of competition ( $p < 0,05$ ), and that the differences between the national and international level were not significant.*

**Key words:** Big five plus two, Personality dimensions, sport, success

### 1. Introduction

The candidates for enrolment in the Faculty of Sport and Physical Education of the University of Novi Sad are mostly the population of adolescent athletes,

that is, the persons who play sports actively. This period of development is characterized by preparation for achievement of full physiological, social, psychological and economic maturity. Prominent development of self-awareness and personal identity is typical for this period of life. Along with all natural laws and dynamics of biological maturing caused mostly by endogenous, genetic factors, this period is also specific for the strong impact of the environment (Krueger & Johnson, 2008).

Some previous researches dealt with the role of active sport in the process of personality development, i.e. whether time spent in "sport atmosphere" or sport surroundings contributed to healthy development of personalities of young people. It was established that through participation in sports, children and adolescents were frequently exposed to concepts which applied to adults, such as organization, discipline, fair play, resoluteness and teamwork, which have positive impact on the entire process of maturation. Personal characteristics frequently observed in adults who used to play sports during their maturation are lower level of neuroticism, high level of ability to adjust and conscientiousness. Emotional processes which occur during continuous overcoming of oneself or opponents during sports preparations and competitions, contribute to positive personal development, and gradually lead to better level of self-control, emotional stability and achievement of even better results in sports (Havelka and Lazarević, 1981).

The researches were initiated as far back as in the first half of the XX century, and today we have certain findings that there is a link between personality and success in sport, and based on the personality characteristics the athletes significantly differ from non-athletes, and that within the "sports population" there are also substantial differences in personality characteristics, particularly in regards to the achieved level of success during sport career. Athletes who reached international level of competition are substantially different in personality dimensions from the athletes of national and local level (Allen, Geenless, John 2013).

Since it has been established that there is a strong correlation between personality and sports achievement, the authors were interested in the structure of candidates for enrolment in the Faculty of Sport and Physical Education in respect of physiological characteristics, i.e. what their average psychological profiles were, and whether there were differences in personality dimensions compared to the achieved level of success in sports, in case they competed on international, national or local level.



## 2. Materials and methods

### *Participants*

Total number of participants included in this research was 121, all candidates for enrolment in the Faculty of Sport and Physical Education of the University of Novi Sad, with average age  $18.75 \pm$ . After inspection of the filled questionnaire, out of the total number of participants, it was established that 121 of them played sports, and 5 of them failed to adequately respond to the questions and were thus exempt from further analysis. It was established that the equal number of participants were local ( $n=48$ ) and national ( $n=41$ ) level athletes, and somewhat smaller number of them were athletes of international level ( $n=32$ ).

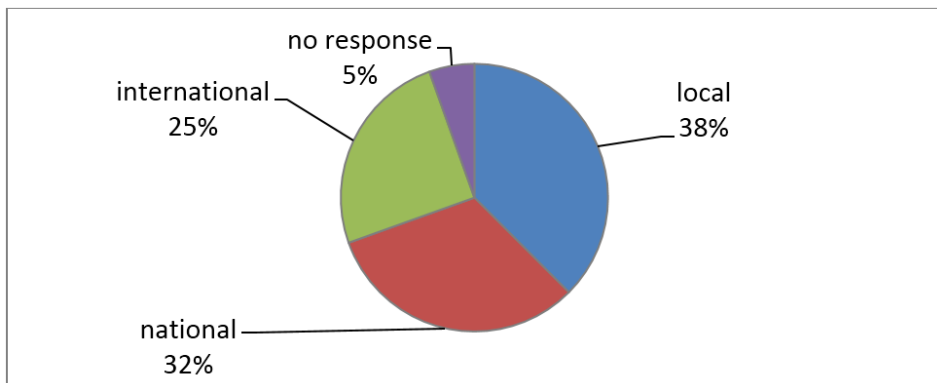

Chart 1. Structure of the sample in regards to the level of success in sport

### *Measurements*

In order to establish personal characteristics on the sample of adolescent athletes, for the needs of this research, **seven factor model** of personality was used, methodologically based on Lexical hypothesis based on which all socially relevant terms and terms relevant for description of personality are contained and coded in spoken language (Čolović, Mitrović and Smederevac, 2005). The model *Big five plus two* is the model which originated from the continuation of psychological -lexical study of Serbian language, based on which the dimensions of five factor model were kept – neuroticism, extraversion, openness to experience, kindness and conscientiousness, and two factors of self-assessment were joined - positive and negative valence from the seven factor model (Smederevac, 2000; Madic, , Korovljev, Popovic,

& Obradovic, 2016). It was successfully confirmed by numerous cross-cultural researches. *The questionnaire Big five plus two* consists of 184 statements and offered five-level Likert-type scales for responses. It presents operationalization of the combination of five factor and seven factor model for evaluation of personality dimensions. It consists of 7 scales: Neuroticism, Extraversion, Conscientiousness, Aggressiveness, Openness to Experience, Negative Valence and Positive Valence.

Each of the sub-scales has its own sub-scales intended for evaluation of sub-dimensions. All the scales and sub-scales are highly reliable. The scale Neuroticism has the best metric characteristics, and the lowest quality ones are for Negative Valence. The final results of the BF+2 questionnaires are received by conversion of raw scores into T values. That is a special form of standard score and is calculated based on the formula  $T=10*Z+50$ , where  $Z = (\text{raw score} - \text{arithmetic mean})/\text{standard deviation}$ . Raw scores for each scale of the questionnaire are calculated by adding the responses to those items. The templates of this questionnaire have the indication which items belong to which scale and that the responses should be simply added up. High T values are the scores in the range 55 – 65, and low values are the scores below 35. The values in the range 45 – 55 are considered to be average scores.

*Procedure* The testing was completed within regular preparations for taking of the enrolment exam at the Faculty of Sport and Physical Education, University in Novi Sad. Preparations for the enrolment exam take one month. Within that period, the candidates who apply undergo different forms of physical and theoretical preparations in order to better understand the terms used in sport and physical education. Psychological testing was done at one of the theoretical lessons, where the participants took part voluntarily, and were divided into two equal groups in respect of the numbers. Testing of each group took 60 minutes and was done with professional supervision of a psychologist and organizational assistance of professors and coordinators of official preparations for the enrolment exam for the Faculty of Sport and Physical Education, University in Novi Sad.

*Statistical analysis* Basic descriptive statistics were used to show indicators of personality characteristics depending on the level of sport activities. The method of Chi-square test was applied for establishing of the differences between the participants considering their success thus far. Univariate (ANOVA) analysis of variance was used for establishing of difference

between the participants who took part in international, national or local level competitions, which was followed by Post hoc test to determine the significance of differences by pairs of groups in psychological dimensions in different categories of success in sport of future students.

### 3. Results and discussion

Basic descriptive indicators of analysed personality dimensions of adolescents are shown in Table 1. Only those participants (n=121) who stated they played sports, as well as those who provided information of the level of competitions, were taken into consideration. On the basis of descriptive indicators of personality characteristics shown in Table 1, it may be concluded that the participants had higher value of scores on the dimensions Extraversion, and somewhat lower on the dimensions Negative Valence and Neuroticism.

**Table 1.** Results of descriptive statistics for personality dimensions BF+2 (Big Five + 2)

<b>Dimensions <i>BF+2</i></b>	<b>AM</b>	<b>S</b>	<b>Min</b>	<b>Max</b>
Neuroticism	74	17.9	38	115
Extraversion	100.9	8.7	77	118
Conscientiousness	108.7	12.8	77	135
Aggressiveness	77.7	13.7	46	112
Openness	76.9	9.2	57	100
Positive Valence	87.3	11.7	58	122
Negative Valence	38.4	9.0	22	65

AS – arithmetic mean

S – standard deviation

Min – minimum value

Max – maximum value

In order to enable comparison between the scales in scores, the results of questionnaires were transformed in T-values. On the basis of the results shown in Table 2, it is observed that the highest values of T – scores were achieved by the participants in the area of Conscientiousness and Extraversion, and the lowest values in the area of Neuroticism and Negative Valence, while in the remaining four dimensions the results were pretty equal. Comparing the

results of T- scores between genders, it is observed that the values in all the scales are balanced, and that female adolescents tend to approach upper limits on the scales Extraversion and Conscientiousness.

**Table 2.** Average values of T scores for dimensions BF+2 based on gender

Dimensions <i>BF+2</i>	Male gender		Female gender	
	Raw score	T score	Raw score	T score
Neuroticism	75.2	50.7	70.8	48.2
Extraversion	<b>99.4</b>	<b>48.2</b>	<b>105</b>	<b>54.7</b>
Conscientiousness	<b>106.5</b>	<b>48.3</b>	<b>114.7</b>	<b>54.7</b>
Aggressiveness	77.8	50.1	77.4	49.8
Openness	76	49	76.3	52.7
Positive Valence	86.5	49.3	89.6	51.9
Negative Valence	40	51.8	34	45.2

In order to establish the differences between three groups of participants shown in the Table 3, Chi-square test was used before the analysis and it was established that the groups analysed based on the success in sports (local, national and international) did not differ in the number of men and women. Since Chi-square test is not significant ( $\chi^2 = 0,28, p > 0,05$ ), raw scores were used for the analyses, and not T- values based on the norms for men and women.

The analysis of variance showed that there were statistically significant differences in the scores on the personality dimensions Positive Valence ( $F = 4,708, p \leq 0,01$ ) and Conscientiousness ( $F = 3,556, p \leq 0,05$ ), and that it could be said that the participants who competed on the international level had higher scores on the dimensions Conscientiousness and Positive Valences compared to other two observed categories. Post hoc analysis (Tukey) has shown that within the dimensions Conscientiousness and Positive Valences, there were significant differences between local and international level of competitions ( $p < 0.05$ ), and that the differences between national and international level were not significant.

**Table 3.** Results of the analysis of variance (ANOVA) for evaluation of significance of differences on BF+ 2 between the participants based on the level of their success in sport

<i>BF+2</i>	Level of competition	N	AM	S	F	p
Neuroticism	local	48	75.3	17.0	0.81	0.45
	national	41	75.2	17.8		
	international	32	70.6	19.5		
Extraversion	local	48	99.6	9.0	1,42	0.25
	national	41	101.0	9.8		
	international	32	102.9	6.5		
<b>Conscientiousness</b>	local	48	106.0	12.3	3.56	<b>0.03</b>
	national	41	108.1	13.4		
	international	32	113.5	11.9		
Aggressiveness	local	48	77.0	12.1	0.15	0.86
	national	41	77.7	16.5		
	international	32	78.7	12.5		
Openness	local	48	74.8	8.5	2.12	0.13
	national	41	78.2	9.9		
	international	32	78.4	8.9		
<b>Positive Valence</b>	local	48	83.7	10.0	4.71	<b>0.01</b>
	national	41	88.5	12.4		
	international	32	91.4	11.7		
Negative Valence	local	48	38.0	8.7	2.01	0.14
	national	41	40.5	10.3		
	international	32	36.3	7.3		

AN – arithmetic mean

F – value of F test

S – standard deviation

p – statistical significance

#### 4. Conclusions

Based on the received results on average values of personality dimensions on the complete sample of participants, candidates for the enrolment in the Faculty of Sport and Physical Education of the University of Novi Sad, it can

be said that this sample is characterized by higher values on the dimensions Extraversion and Conscientiousness, while other characteristics are average. As previously stated, the previous researches confirmed that the population of athletes demonstrated high level of extraversion compared to those who did not play sport, and that they expressed higher level of emotional stability and Conscientiousness (Allen, Greenless, John, 2013). Since the *Scale Extraversion* presents the dimension of individual differences in the level of reactivity to the outside environment and relates to resoluteness, sociability and positive affect, which includes optimistic behaviour, high level of energy and serenity, it may be said that the examined sample has these characteristics and behaviours to the most extent. The analysis of the dimension Conscientiousness shows that unlike other dimensions it includes the component of wilfulness and could be called "will power" (Smederevac, Mitrović, Čolović, 2009). Thus, it is observed that this sample of participants has mentioned characteristics and behaviours which are in compliance with previous researches within the population of athletes. In the domains of other analysed personality dimensions Neuroticism, Negative Valence, Openness and Aggressiveness, it can be said that they belong to normal average values.

Based on the results received though univariate (ANOVA) analysis of variance it can be said that the participants who belong to international level of competition differ in characteristics Conscientiousness and Positive Valence compared to the athletes of lower level, i.e. those who compete on national and local level. Received results in favour of the athletes of the international level show that these persons have more positive attitude towards their abilities, talents and virtues and better self - image, as well as the component of compliance and adjustment to the society and environment. Since the dimension of Conscientiousness is prominent, it is concluded that the athletes of international level have lower tendency of carelessness, and put greater efforts in the direction of self-discipline and compliance with the rules. One of the studies which included British gymnasts also confirms these findings, and points out to certain differences in respect of the period of preparations and competitions, and that the Conscientiousness is positively linked with the quality of preparation of an athlete in the period before the competition, and emotional stability is positively linked with efficient adjustment during the competition (Woodman, Zourbanos, Hardy, Beattie, & McQuillan, 2010). Furthermore, in some studies which include athletes with high level of conscientiousness, openness and emotional stability it is observed that they

have more tendencies towards use of strategies for dealing with problems and they are less aggressive (Trninic, Barancic & Nazor, 2008)

These conclusions that the athletes on international level are significantly different from the athletes of local, team level in the personality characteristics, had been made by other researches as well, before the difference between athletes of national level and other two categories was discovered. Recently, lower level of neuroticism and higher level of conscientiousness and compliance was found in the athletes competing on national and international competitions compared to the athletes who play in teams or on the regional level (Allen, Greenlees, & Jones, 2011.)

This finding was explained by Silva through presentation of the phenomenon of the sport personality pyramid. This phenomenon explains that with the increase of the level of competition, the differences in the structure of personalities of competitors occur, where they becomes more homogenous. As stated based on this model, at the bottom of the pyramid are beginners in sport, then athletes of national, and then of Olympic level who strive towards the top of the pyramid reserved for the top athletes (Tišma 2008).

This research constitutes an original attempt to expand the research in the domain of psychology of sport and to design more complete drafts which will contribute to development of this field in order to improve the information on possibilities for development of new methods for achievement of success in sport in the population of adolescent athletes.

## 5. References

1. S., Allen, M. I. Greenlees, and M. Jones. "An investigation of the five-factor model of personality and coping behaviour in sport." *Journal of sports sciences* vol.29, no.8, (2011), pp.841-850.
2. S., Allen, M. Iain Greenlees, and Marc Jones. "Personality in sport: A comprehensive review." *International Review of Sport and Exercise Psychology*, vol.6, no.1 (2013), 184-208.
3. R. J., Eagleton, S. J. McKelvie, and A. De Man. "Extra Version and Neuroticism in Team Sport Participants, Individual Sport Participants, and Nonparticipants." *Perceptual and motor skills* vol.105, no. 1, (2007), pp. 265-275.
4. D., Madic, D., Korovljevic, B., Popovic and B. Obradovic, "The Dimensions of Adolescent Personality in Relation to Belonging to Collective or Individual Sports." *Arena-Journal of Physical Activities* vol.1. no. 4, (2016), pp 44-56.

5. Smederevac, S., D. Mitrović, and P. Čolović. "Velikih pet plus dva: primena i interpretacija." Beograd, Centar za primenjenu psihologiju, **(2010)**.
6. M., Tišma, "Razlike u afektivno-motivacionim dispozicijama s obzirom na vrstu sporta i nivo uspešnosti sportista." Primenjena psihologija, **(2009)**. vol. 2, no 1, 93-109.
7. V. Trninić, M. Barančić, and M. Nazor. "Peterofaktorska analiza ličnosti i agresivnost." Kineziologija, vol. 40, no.2 **(2008)**, pp. 171-182.
8. Tubić, Tatjana, Višnja Đorđić, and Sunčica Poček. "Dimensions of self-concept and sports engagement in early adolescence." *Psihologija* vol.45. no. **2 (2012)**, pp.209-225.
9. N. Havelka, Lj. Lazarević, "Sport i ličnost. Beograd" Sportska knjiga, Beograd, **(1981)**.
10. F., Krueger, Robert and Wendy Johnson. "Behavioral genetics and personality." Handbook of personality: Theory and research **(2008)**, pp. 287-310.
11. Woodman, Tim, et al. "Do performance strategies moderate the relationship between personality and training behaviors? An exploratory study." *Journal of Applied Sport Psychology* (22).2 **(2010)**, pp. 183-197.

### Author Info

Corresponding author: korovljevdarinka@gmail.com



# Impact of dietary supplements in professional sports: a pilot study

Diana Gluhak<sup>1</sup>, Damir Zubac<sup>2</sup>

<sup>1</sup>Red Fork Consulting

<sup>2</sup>Faculty of Kinesiology University of Zagreb

## Abstract

### Introduction

Typically, professional athletes use various dietary supplements in order to enhance their athletic performance. Indeed, many professional athletes (including ~85% of elite track and field athletes) habitually use dietary supplementation in order to ensure highest competitive results (1). This is based on their attempts to meet energy requirements during competition. For example, in order to completely replenish skeletal muscle glycogen concentrations or rehydrate themselves, athletes consume various supplements including different combinations of whey protein, amino-acids, commercial sports drinks ect. Nevertheless, meeting daily energy and nutritional requirements must also be measured within the scope of micronutrient requirements, such as vitamins and minerals (2). Having said that, vitamin and mineral function in the human body plays an important role of metabolic regulator, and is influencing a number of physiological processes previously shown to be a prerequisite of successful sport performance (3). Interestingly, coaches athletes themselves commonly overlook the rate of nutrient absorption from small intestinal into bloodstream that plays a crucial role in maximizing rehydration or glycogen restoration for example. Over the last decade, several studies have shown inconsistent data concerning the effect of multivitamin / mineral supplementation on physical performance during intense preparation or competitions (4). Therefore, the aim of this study was to examine the differences in consumption of macro and micro nutrient intake among various team sports athletes.

### Methods

This study was an observational cross-sectional self-reported survey. The participants in this study were 74 elite athletes from various team sports (males;

55.6% and females 44.6%). Initially, during study enrollment, written information and a detailed description of the study procedures were sent via e-mail to all participating athletes. The collected data included variables obtained from the questionnaire on various dietary supplement consumption. The questionnaire was a combination of questionnaire previously validated in National Health and Nutrition Examination Survey (NHANES) study and other questionnaires designed for athletes from different team sports regarding similar issues. General prevalence of macro- and micronutrient intake was initially calculated, whereas the chi-square test was used to determine the associations between the dependent variables.

### **Results**

The questionnaire demonstrated appropriate reliability, since the test-retest correlation for ordinal variables ranged from 0.97 to 0.99. There were no differences between the macro- (protein-based supplements) and micro (vitamin-based supplements) nutrient intake  $\chi^2=0.463$ ,  $p=0.496$ . Self-reported data on general prevalence of supplement consumption across this survey documented that only 10% of all athletes habitually consumes protein-based supplements, 13% of them consumes vitamin based supplements whereas only 5% simultaneously consumes both.

### **Conclusion**

Our findings raise a number of questions concerning balanced nutrition and supplement choice in general that are critical for maximizing athletic performance. Therefore, careful planning and assessment of various nutritional aspects is necessary for individual approach to meet daily intake requirements and in some cases this includes dietary supplement consumption. Dietary supplements are still considered to be important sources of nutrients, primary vitamins and minerals, and other nutrients, single or in combination, with physiological effect that has a purpose to additionally enhance daily diet in order to maximize athletic performance while maintaining general health. It is well known that appropriate choice of various supplements for professional athletes is dependent on their gender, sport type, individual goals, current physical status, individual nutrition, allergies, other external factors as well. Since some of the supplements can even impair sport performance (5), the choice of dietary supplementation should be evidence-based, and adjusted for individual needs of different athletes bearing in mind subsequent effects on sports performance.

---

### References

- (1) Maughan, R.J., „The use of dietary supplements by athletes“, Volume 25, 2007: The 2007 IAAF Consensus Conference on Nutrition for Athletics
- (2) Vitamin and mineral requirements in human nutrition: report of a joint FAO/WHO expert consultation, Bangkok, Thailand, 21–30, 2001.
- (3) Williams, Melvin H. “Dietary Supplements and Sports Performance: Introduction and Vitamins.” *Journal of the International Society of Sports Nutrition* 1.2 (2004): 1–6. PMC. Web. 14 July 2017.
- (4) NR Rodriguez, NM DiMarco, S Langley (2009) Nutrition and athletic performance - Medicine and science in sports and exercise
- (5) Williams M.H., *Dietary Supplements and Sports Performance: Introduction and Vitamins. Journal of the International Society of Sports Nutrition*, 1(2):1-6, 2004.

### Author info

Corresponding author: [diana@redfork.hr](mailto:diana@redfork.hr)

## **Analysis of total distance covered by football player age 14-18 year old in a football match**

Arben Bici, Astrit Hafizi

*Scientific Research Institute of Sports, Sports University of Tirana*

### **Abstract**

**A**nalysis of distances that players age 14-18 years old cover in a football match will take place through two methods, notational and Global Positioning System (GPS devices) which will give us Information about volumes and intensities of running. Measurement and analysis which are performed by protocol and GPS technology for the first time in Albanian sport.

*Purpose of the study was recording of physical and functional qualities of athletes in the field, their current conditioning dynamics of volumes and intensities according to the position on the field which then it helps in drawing up and improvement of training programs.*

*The hypothesis that methods based on visual assessment of the performance of the physical activity players during the match without the use of measuring instruments is not correct, inefficient and do not provide opportunities to draw up training programs.*

### **Objectives:**

1. Introducing protocols with GPS measurements of players on the field as a tool of real assessment of the performance during the match.
2. Drawing up of personalized training methods that serve in the improvement performance.
3. Promotion and putting the attention on the importance of using this technology in all areas of training in Albania.

## The methodology of the study

In four matches of Albanian Football Superliga and amateur league, age category U - 15, U - 17 and U - 19, in the month of October 2016, were analyzed four players on their performance of physical activity during the game by two methods notational (record keeping) and global positioning system (GPS) at the same time.

In the case of measurement with notational method a sketch of football field reduced scale reduction in 1: 600

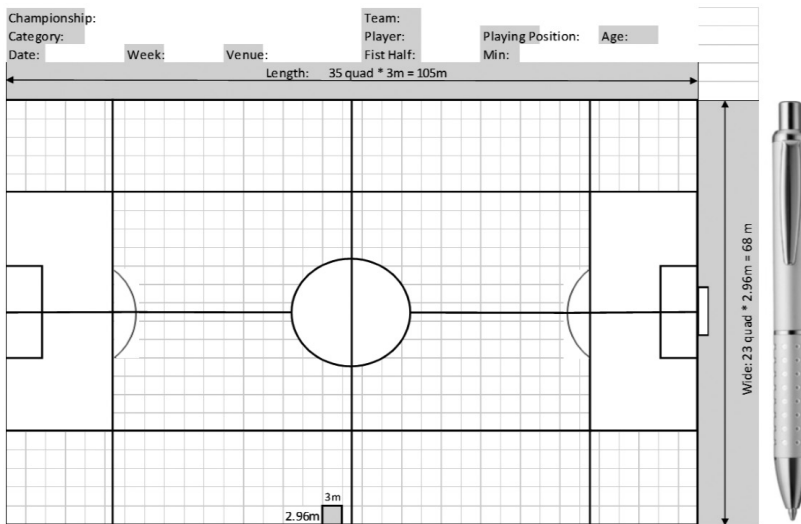

The running distance and the speed of movement areas for study purposes was calculated by means of measuring the measuring unit where a square in table with dimensions measuring 0.5 cm x 0.5 cm = a quad area measuring 3m x 3m.

Real dimensions of the field are as follows:

Length 105 m = 17.5 cm in outline

Width 69 m = 11.3 cm in outline

Level data that determine the speed of movement were as following:

1. Walking - Jogging



2. Moderate Running



3. High and Sprint



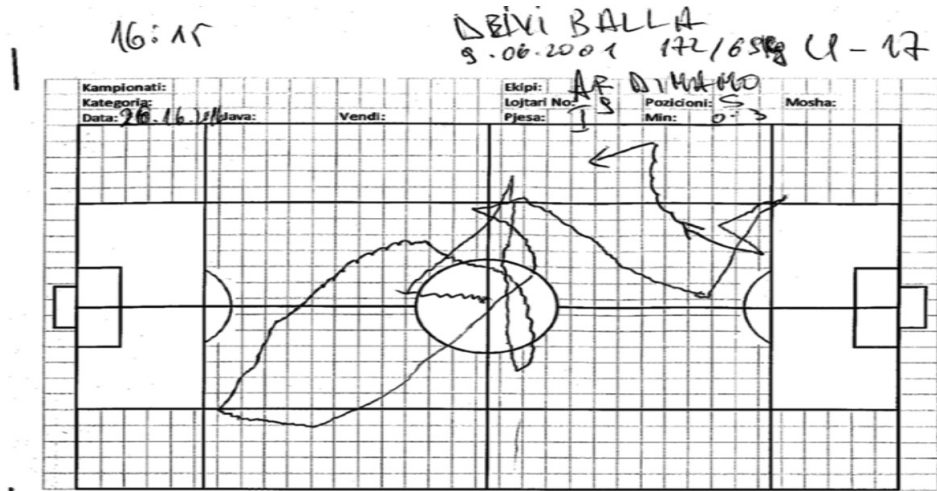

Movement Analyzing with global positioning system (GPS)

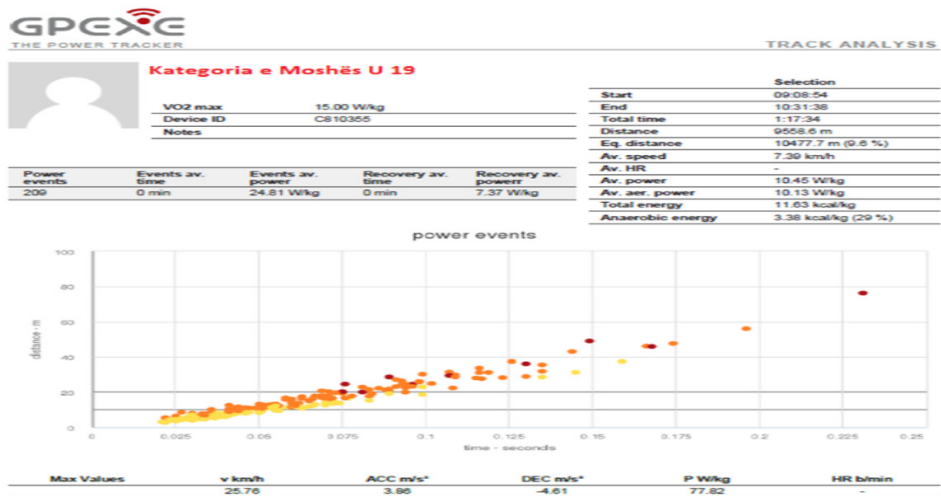

In case of measurement with global positioning system GPS device GPEXE Company 20 HZ was used.



20 HZ GPS = 20 SAMPLES/SEC  
TRACKING SPEED WITH HIGH ACCURACY

Measuring of speed level, by using instruments method with global positioning system, were selected five categories of speed of movement of players, focusing on speed movements such as the following levels:

0-8 km / h; 8-16 km / h; 16-19 km / h; 19,1-23 km / h and > 23 km / h.

Taking into account that in this study we had in use only one device of GPS we selected only four official matches, one of the age categories U-15, an age category U - 17, and two category aged U - 19.

The data obtained from measurements of the distance covered and intensities were then elaborated into an Excel table format where the comparisons of data measurements with both methods were made.

The summary table shows the inaccuracy of notational method ranges from 14% - 23% compared with the method of GPS global positioning system.

Results of measuring the total distance in meters							
Age Category	Time min	Notational	M/min	GPS	M/min	Dif. meter	Inaccuracy %
U 15	58	5688	98	6596	114	-908	14
U 17	58	6024	104	6968.9	120	-944.9	14
U 19	76	7359	97	9510.9	125	-2151.9	23
U 19	90	8136	90	10235.4	114	-2099.4	21

In conclusion, this study has its limitations because of the small number of players taken in the analysis and the lack of device which enables analysis of physical performances of players.

Yet, research shows that traditional methods of assessing physical performance of players in a match by means of visual perception of distances

and intensities of running is inaccurate, inefficient and spend more time to extract data.

With notational method, in a match, a researcher can take notes only for one single player. Time required to obtain data for one player is about three hours. So, in a workday can extract data for only three players and a team will take approximately three days.

As a result the coach will not be able to prepare the team for the next match.

In most cases, studies have analyzed the category of adult age and very few are committed to analyzing physical performance of youth in game even though they are the largest number of players. Youth footballers have physiologic development processes different from those of adults and therefore should be the importance of the study of physical performance during the game at this age.

GPS device with the advantages of analyzing and assessing the age's specifications may result and help to increase the performance of young players.

**Keywords:** Analyze, distance, run, soccer player, notational, Global Positioning System (GPS)

## References

1. Christofer Carling, A. Mark Williams and Thomas Reilly "Hand Book of Soccer Match Analysis" 2007
2. Thomas Reilly and A Mark Williams " Science and Soccer " 2003
3. M. Buchheit , A. Mendez-Villanueva , B. M. Simpson , P. C. Bourdon "Match Running Performance and Fitness in Youth Soccer"2010

## Author Info

E-mail: arben.bici@hotmail.com



## Changes in Isometric Endurance of the Lumbar Extensors in Children

Nikola Jevtić<sup>1,2</sup>, Borislav Obradović<sup>2</sup>, Jelena Paušić<sup>3</sup>, Sasa Radosav<sup>4</sup>, Milan Pantović<sup>5</sup>, Dragan Marinković<sup>2,3</sup>, Aleksandar Karać<sup>1</sup>

<sup>1</sup>Scolio Centre, Novi Sad, Serbia

<sup>2</sup>Faculty of Sports and Physical Education, University of Novi Sad, Serbia

<sup>3</sup>Faculty of Kinesiology, University of Split, Croatia

<sup>4</sup>Shenzhen Forefront Innovation Culture Development Co., LTD, Qushui Bay, Shenzhen, China

<sup>5</sup>H2Drinks, Laughlin, Nevada, USA

### Abstract

**M**uscles of the trunk have a significant role in mobility and stabilization of the spinal column. The occurrence of pain and early fatigue in the lumbar part of the spinal column may be the consequence of reduced endurance of the lumbar extensors. The aim of this research was to determine changes in isometric endurance of the lumbar extensors in children from 11 to 18 years of age and to define differences in male and female subgroup of participants. The research included healthy male and female population from 11 to 18 years of age. Testing was conducted on the sample of 609 participants, divided into two subsamples, 349 male and 260 female, and subsamples were divided into 8 age subgroups. Isometric endurance of the lumbar extensors was determined by conducting the Biering-Sorensen test. One-way univariate analysis of variance (ANOVA) was used for processing data, and the "Post Hoc" method was used to determine the differences of each group individually. There are statistically significant differences of the isometric endurance of the lumbar extensors in 11 to 18-year-old children between the generations ( $F=14.57$ ;  $p=0.000$ ). Differences were also noticed in both subsamples, slightly larger differences in male participants ( $F=10.88$ ;  $p=0.000$ ), than in female participants ( $F=7.44$ ;  $p=0.000$ ). Children should be engaged into corrective activities, primarily in puberty which appeared to be the most critical period for postural status in children.

**Keywords:** Lumbar extensors, isometric endurance, children.

## 1. Introduction

Muscles of the trunk have a significant role in mobility and stabilization of the spinal column (Yasuda et al., 2013). The occurrence of early fatigue and reduced endurance of spinal extensors may be a sign of the lumbar facet syndrome and one of the factors in its etiology (Van Dieen et al., 1998) in children as well as in adults (Jevtic et al., 2013; Dejanovic et al., 2013). This is one of the vital groups of the muscles providing good stability of the lumbar segments (McGill, 2007). That means that tests for muscle endurance may be useful in functional and clinical diagnostics in order to determine the connection with the lumbar facet syndrome (Yasuda et al., 2013). Cyclic connection of strength and endurance of the lumbar extensors has a significant role in prevention of lumbar problems (Biering-Sørensen, 1984; Dejanovic et al., 2012).

During the process of growth and development, the spinal column is one of the key point of body that is sensitive to the effects of external factors, and there are frequent cases of power reduction of abdominal and back muscles (Bogdanovic et al., 2014). In some sports activities, less height and weight are necessary to achieve maximum results, while in others higher height and weight are necessary for excellent results (Popovic et al., 2013). Morphological development of the skeletal system does not take place simultaneously with the muscular system, thus muscles cannot keep up with bone growth (Jevtic et al., 2013). This is the reason why puberty may have a negative impact on the spinal column. The spinal column is sensitive to external factors thus that is an additional reason which can lead to back pain or some spinal deformity (Viry et al., 1999). It is known that mechanical forces may influence both shape and growth of the bones.

The purpose of this research is to determine changes in the arithmetic mean by application of the Biering-Sorensen test in children from 11 to 18 years of age and to determine whether there are statistically significant differences in the arithmetic means within the subgroup consisting of female participants and a subgroup consisting of male participants. It is assumed that the period of puberty may be one of the factors influencing the progression process of muscle endurance of the lumbar extensors, and that differences may be detected at that period of life, as well as that those changes will be detected earlier in female than in male patients, which was proved in the more research (Jevtic et al., 2013). It is also assumed that such result is obtained exclusively due to differences in biological maturity.

## 2. Materials and methods

This experimental research comprised healthy male and female participants from 11 to 18 years of age. The testing was attended by 609 children (349 male and 260 female participants). Participants were divided into 8 age categories. The first age group comprised of 11-year-old children (n=117) participants; the second group comprised of 12-year-old children (n=78) participants; the third group comprised of 13-year-old children (n=44) participants, the fourth group comprised of 14-year-old children (n=76) participants; the fifth group comprised of 15-year-old children, n=58 participants; the sixth group comprised of 16-year-old children (n=95) participants; the seventh group comprised of 17-year-old children (n=77) participants; and the eighth group comprised of 18-year-old children (n=64) participants. All participants are pupils of "Sonja Marinković" Primary School from Novi Sad, "High School of Economics" from Novi Sad.

The Biering-Sorensen test was used during the research with the aim to determine isometric endurance of the lumbar extensors (Biering-Sørensen, 1984). The Sorensen test is a method commonly met in literature and it is considered a reliable and safe instrument for measurement of isometric endurance of the lumbar extensors (Moffroid, 1997). When the function of the spinal column is concerned, it measures how much lumbar musculature of a participant can endure in the isometric contraction. The maximum duration of endurance may be up to 240 seconds; after that period of time, the test is terminated due to precautions. The test is conducted by a measurer who holds the lower extremities of the participant, and the other measurer controls the accuracy of the test and measures the time. At the measurer's signal, time begins to run, and the participant takes a position as previously explained in the text. For every movement or distortion of the previously explained position, the participant is being warned; after two warnings, the test is terminated. After the test, time is measured in seconds with the accuracy of 0,1.

The statistical Package for Social Sciences SPSS (v17.0, SPSS Inc., Chicago, IL) was used for the statistical analysis. One-way univariate analysis of variance (ANOVA) was used to assess differences between groups. When a significant F value was achieved, appropriate Tukey's post hoc test procedures were used to locate the difference between the means. The data are expressed as means standard deviation. Statistical significance was set at  $p < .05$ .

### 3. Results and discussion

The obtained results of this research were presented in tables and graphics. First are presented the mean of isometric endurance of the lumbar extensors in 11 to 18-year-old children (Table 1). Distribution of the arithmetic mean indicates that there are statistically significant differences in isometric endurance of the lumbar extensors among different generations of children ( $F=14,57$ ;  $p=0.00$ ). The largest differences were recorded between the 13-year-old and 16-year-old students to the benefit of students of 13 years of age; the average difference between the two age groups was 80.73 seconds. The smallest differences in the arithmetic mean were recorded between the 11-year-old and 15-year-old students, where, on average, the former had 1.99 seconds better endurance than the latter. Minimum values indicate that 17-year-old students had the smallest value in the recorded results, which stood at 22.14 seconds, while the maximum values indicate that 14-year-old students had the highest ranked result of all generations, i.e. 544.27 seconds.

**Table 1.** Isometric endurance of the lumbar extensors in 11-year-old to 18-year-old children

Age	N	M	SD	MIN	MAX
11	117	175.92	57.07	61.91	373.49
12	78	190.67	53.97	85.26	341.74
13	44	239.79	79.79	83.73	449.80
14	76	233.84	68.89	98.44	544.27
15	58	173.93	63.50	26.01	337.09
16	95	159.06	57.25	45.36	400.14
17	77	176.89	67.01	22.14	364.12
18	64	186.45	59.40	77.73	400.58
	F=14.57		p=0.000		

Legend: \*Mean represents the arithmetic mean of isometric endurance of the lumbar extensors. The minimum and maximum columns represent the range of the result; SD stands for standard deviation.

Then they presented the mean of endurance of the lumbar extensors in 11 to 18-year-old boys and girls (Table 2). One-way univariate analysis of variance (ANOVA) indicates that statistically significant differences are recorded in both

subsamples. In boys, the F value is slightly larger than in girls and it amounted  $F= 10.88$ ;  $p= 0.000$ , while in girls that value amounted ( $F=7.44$ ;  $p= 0.000$ ). Certainly, the results in both subsamples indicated a significant difference.

**Table 2.** Isometric endurance of the lumbar extensors in 11 to 18-year-old boys and girls

Age	Gender	N	M	SD	MIN	MAX
11	Boys	67	171.59	56.95	61.91	367.42
	Girls	50	181.73	57.29	78.15	373.49
12	Boys	40	194.62	51.39	99.27	287.21
	Girls	38	186.55	56.98	85.26	341.74
13	Boys	22	247.12	70.20	146.57	403.25
	Girls	22	232.47	89.43	83.73	449.80
14	Boys	41	236.36	70.16	98.44	544.27
	Girls	35	230.89	68.26	119.83	366.19
15	Boys	30	176.07	65.14	26.01	310.25
	Girls	28	171.64	62.81	51.11	337.51
16	Boys	57	166.60	49.50	81.35	304.53
	Girls	38	147.76	66.33	45.67	400.15
17	Boys	50	185.42	58.71	63.24	364.57
	Girls	27	161.11	78.95	22.57	364.45
18	Boys	41	163,29	38.93	77.47	249.25
	Girls	23	227.78	67.53	111.14	400.36
		Boys: $F= 10.88$		$p=0.000$	Girls: $F: 7.44$	
					$p=0.000$	

Legend: \*Mean represents the arithmetic mean of isometric endurance of the lumbar extensors. The minimum and maximum columns represent the range of the result; SD stands for standard deviation.

Sample comprising of boys indicates that the largest differences in the arithmetic mean were recorded between 13 and 18 years of age, where the 13-year-old student's approximately had 83.83 seconds better results from 18-year-old students. The smallest differences were recorded in 16 to 18-year-old students, where 16-year-old students were better for 3.31 seconds on

average. In girls, the situation was slightly different; the largest recorded differences in the arithmetic mean were between 13 and 16-year-old girls, where 13-year-old girls were 84.71 better seconds on average. The minimal recorded differences were between 13 and 14-year-old female students; the average difference was 1.58 seconds in favour of 13-year-old girls. The values presented (Table 3.) represent statistically significant differences in the mean within male and female population according to age.

**Table 3.** Differences in the isometric endurance of the lumbar extensors within male and female population according to age

Age	Gender	12	13	14	15	16	17	18
11	Boys	0.044*	0.000*	0.000*	0.721	0.628	0.195	0.463
	Girls	0.741	0.003*	0.001*	0.525	0.019*	0.199	0.007*
12	Boys		0.001*	0.001*	0.179	0.018*	0.448	0.014*
	Girls		0.011*	0.005*	0.347	0.012*	0.134	0.021*
13	Boys			0.476	0.000*	0.000*	0.000*	0.000*
	Girls			0.931	0.002*	0.000*	0.000*	0.815
14	Boys				0.000*	0.000*	0.000*	0.000*
	Girls				0.001*	0.000*	0.000*	0.863
15	Boys					0.462	0.478	0.351
	Girls					0.154	0.561	0.003*
16	Boys						0.090	0.776
	Girls						0.430	0.000*
17	Boys							0.066
	Girls							0.001*

Legend: \*Statistically significant differences in the mean within male and female population according to age (sig).

It was noticed that a slight progress was made in muscle endurance of the lumbar extensors between 11 and 12 years of age, then a sudden increase at the age of 13 was recorded and thereafter static strength began to decline until 17 years of age, when there is a slight increase that continues until the age of 18 (Fig. 1.).

**Fig. 1.** Changes in the isometric endurance of the lumbar extensors in 11 to 18-year-old children of both sexes

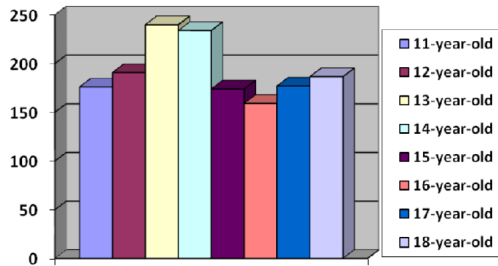

The subsample comprising of boys recorded an increase in muscle endurance from 11 to 12 years of age; afterwards, a sudden progress was recorded at the age of 13, which then was decreasing until the age of 17 when an increase in static endurance was recorded, followed by one minor decline (Fig. 2.).

**Fig. 2.** Changes in isometric endurance of the lumbar extensors in 11 to 18-year-old boys

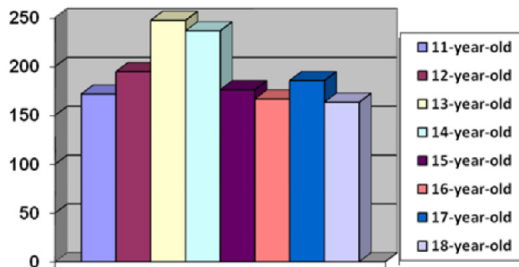

The subsample consisting of girls recorded similar results. As in previous cases, the largest increase in muscle endurance was recorded between 12 and 13 years of age; a decrease in muscle endurance was also recorded after the age of 14 and the first increase after that was recorded at the age of 17. After that period, a sudden increase in muscle endurance was recorded (Fig. 3.).

**Fig. 3.** Changes in isometric endurance of the lumbar extensors in 11 to 18-year-old girls

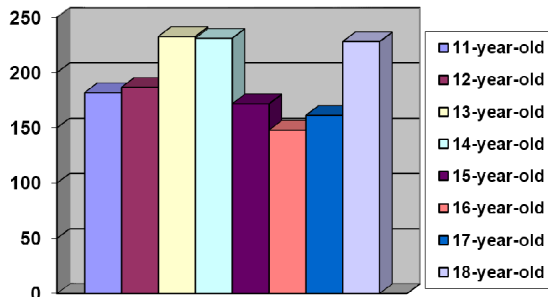

The first purpose of the study was to determine difference in isometric endurance of the lumbar extensors between age groups. The research showed that there was a statistically significant difference in the arithmetic mean of isometric endurance of the lumbar extensors in 11 to 18-year-old children. The second purpose of the study was to determine differences in genders group and result shows statistical significant differences in boys among generations, as well as in girls.

Authors assume that the obtained result of the endurance of both genders, which is graphically illustrated, is exactly as it is due to the fact that children at that age enter the puberty when the relationship between the musculature and skeletal system begins to change. A sudden decline in muscle endurance in children was recorded after the age of 13, which can be considered the most critical period in a child's growth and development. A conclusion that may be drawn from this is that one should pay attention to children at that age. After the age of sixteen, muscular endurance starts to increase in both genders, which tells us that there is a balance between the skeletal system and muscles which support the skeletal system.

Some authors confirmed that physical activity has a significant impact on the isometric endurance of the lumbar extensors. Their study included basketball and football players as a sample, where they found that basketball players have a higher isometric endurance from the football players. The best way to maintain a good posture in the critical period is to be physically active and engaged in the corrective activities (Milenković et al., 2012).

Some authors found that the Sorensen test result may affect the activation of the hamstring muscle (Pitcher et al., 2007). By comparison of the Sorensen and Ito test, some authors eliminated the influence of the hamstring muscles, so that the maximum load in the test transferred to Ito musculus iliocostalis and musculus multifeed, while musculus multifida and musculus semitendinosus had greater activation in the Sorensen test (Muller et al., 2010). This finding has direct clinical implications, by providing parents and clinicians reassurance that as the child takes steps towards using corrective exercise as effective techniques to improve endurance of the lumbar extensors.

#### **4. Conclusions**

These results have confirmed previous findings demonstrated that the period of puberty is one of the most critical periods for the postural status



in children. Reduced physical activity and rapid growth and development contribute to the fact that the muscles cannot cope with the growth of bones, leading to an increased risk for the development of a deformity. It is necessary to engage children in corrective activities in order to act pre-emptively with the problems that increasingly affect young population. It has been confirmed in the previous studies that the Sorensen test can be used in healthy populations and in patients with lumbar problems; it is therefore considered a safe test. However, further research should be conducted to determine the role of hamstring muscles in the Sorensen test.

## 5. References

- Biering-Sorensen, F. (1984). Physical measurements as risk indicators for low-back trouble over a one-year period. *Spine (Phila Pa 1976)*, 9(2), 106-119.
- Bogdanovic, Z., Smajic, M., Jaksic, D., Milosevic, Z., Obradovic, B., Gogic, A., Popovic, S. (2014). Lumbar and Abdominal Muscles Isometric Potential in Volleyball Cadets. *International Journal of Morphology*, 32, 1036-1042.
- Dejanovic, A., Cambridge, E. D. J., & McGill, S. (2013). Does Spine Posture Affect Isometric Torso Muscle Endurance Profiles in Adolescent Children? *Advances in Physical Education*, 03(03), 111-115.
- Dejanovic, A., Harvey, E., Andersen, J., & McGill, S. (2012). Do Anthropometric Measures Influence Torso Muscle Endurance Profiles of Children Aged 7 to 14? *Advances in Physical Education*, 02(04), 187-196
- McGill, S. (2007). *Low Back Disorders Evidence-Based Prevention and Rehabilitation*. USA: Human Kinetics.
- Milenković, S., Bogdanović, Z., Ivković, M. (2012). Deep spinal muscles isometric potential in students of the faculty of sport and physical education. *Facta Universitatis - Physical Education and Sport*, 10(1), 33 - 38.
- Moffroid, M. T. (1997). Endurance of trunk muscles in persons with chronic low back pain: assessment, performance, training. *Journal of Rehabilitation Research and Development*, 34(4), 440-447.
- Muller, R., Strassle, K., & Wirth, B. (2010). Isometric back muscle endurance: an EMG study on the criterion validity of the Ito test. *Journal of Electromyography & Kinesiology*, 20(5), 845-850.
- Pitcher, M. J., Behm, D. G., & MacKinnon, S. N. (2007). Neuromuscular Fatigue During a Modified Biering-Sørensen Test in Subjects with and Without Low Back Pain. *Journal of Sports Science and Medicine*, 6(4), 549-559.

---

Popovic, S., Bjelica, D., Molnar, S., Jaksic, D., & Akpinar, S. (2013). Body Height and Its Estimation Utilizing Arm Span Measurements in Serbian Adults. *International Journal of Morphology*, 31, 271-279.

Shinichi Daikuya, Y. M. (2013). Trunk Muscle Strength in Patient with Low Back Pain. *Orthopedic & Muscular System*, 02(02).

Van Dieen, J. H., Heijblom, P., & Bunkens, H. (1998). Extrapolation of time series of EMG power spectrum parameters in isometric endurance tests of trunk extensor muscles. *Journal of Electromyography & Kinesiology*, 8(1), 35-44.

Viry, P., Creveuil, C., & Marcelli, C. (1999). Nonspecific back pain in children. A search for associated factors in 14-year-old schoolchildren. *Revue du rhumatisme Engl Ed.*, 66(7-9), 381-388.

### Author info

E-mail: [marinkovicdragan@hotmail.com](mailto:marinkovicdragan@hotmail.com)

# Impact of Gender on Attitudes and Habits Towards Fitness and Recreation Among Croatian Actors

Ana Gruica<sup>1</sup>, Lucijana Krželj<sup>2</sup>, Mia Mandić<sup>3</sup>

<sup>1</sup>GKM Split

<sup>2</sup>MD, spec. of occupational and sports medicine, Croatian Primary Health Care Institute –  
Regia Dalmatia Croatia

<sup>3</sup>Faculty of Kinesiology University of Split

## Abstract

*The main goal of this research was to identify the differences in attitudes and habits towards fitness and recreation between male and female actors. According to the goal, sample of 28 actors was used 15 males and 13 females. They filled out the newly constructed questionnaire to determine their attitudes and habits related to fitness and recreation. The questionnaire was validated a priori while coefficient of correlation between test and retest was calculated as measure of reliability. Surprisingly, no statistically significant differences between males and females were identified. The result implicitly showed that fitness and recreation truly werw direct responses to the 21<sup>st</sup> century demands faced by actor.*

**Keywords:** actors, fitness, recreation, habits and attitudes

## 1. Introduction

Studies of habits and attitudes of actors toward fitness and recreation were scarce. On the other hand, but closely connected with habits and attitudes toward fitness and recreation, was the question how much and to what extent was the body used as an actor's instrument in his work? How much does the body mean for and contribute to actors' self-confidence, interpretation and endurance? There were many more questions related to actor population that modern science did not have accurate answers for, or any answer at all (Findaly, 1997). Considering that actors had training habits established

through their educational system, it was important to mention that the system was monitoring each actor in their physical and mental growth (Stanislavski, 1989a). However, with this paper we were to identify the differences in attitudes and habits toward fitness and recreation between male and female actors. In addition, this paper is an effort to prove that each period requires adaptation. It is inevitable that two or three show performances per day as well as exhausting theatrical rehearsals and television shootings unfold at a faster pace in today's cinematography and theatre studies than in the 20<sup>th</sup> century (Stanislavski, 1989b; Stanislavski, 1995). Therefore, the pace of preparation and work today requires more physical engagement. This raises the question of what type and amount of physical fitness is required from a 21<sup>st</sup> century actor who uses the body as one of the main instruments of his work. Surely fitness and recreation are necessities that the dynamics of the 21<sup>st</sup> century raises before actors. According to the above, the goal of this paper was to determine the difference in attitudes and habits toward fitness and recreation between male and female actors as well as to identify the current physical status of the acting community.

## 2. Materials and methods

### *Participants*

Sample was consisted of 28 randomly selected examinees, members of acting community 13 females and 15 males.

### *Measurements*

Newly constructed questionnaire was used especially for this research and answers were on the Likert's scale 1 to 5:

1. I was physically active before contact with Academy of Dramatic Art (PA), 2. I have been physically active for past 15 day (PA15), 3. Currently I have intense training habits (IntsTrain), 4. Over last year I was active for more than 3 times per week (PA>3xWe), 5. I am satisfied with my current fitness status (PFit+), 6. I pay attention on physical activity, readiness and looks of my colleagues (PAColleg), 7. Scene movement class on Academy of Dramatic Art has fulfilled my need for physical activity (ScenMovPA), 8. Physical fitness of an actor is important for acting achievements (PFtnsActsAchv), 9. During education it is necessary to work on physical preparation of an actor

(EdctPPrep), 10. After finishing education, actor should continue with physical preparation (FnshEdctPPrep), 11. During my education I have encountered with term "healthy diet" (EdctHealtFood), 12. Demands of acting roles today require more physical readiness in 21<sup>st</sup> than in 20<sup>th</sup> century (PR21st20st), 13. Training and physical look have greater importance today than in 1990s and earlier (TrainPLook'16/'90), 14. Physical look is important for a 21<sup>st</sup> century actor (PLook21st), 15. We have fallen under the influence of „Americanization“ of actor's figure (USALook), 16. All other acting colleagues are in good physical readiness (CollegPR), 17. Acting colleagues from my group are in good physical readiness (MyCollegPR), 18. Required physical readiness of an actor varies from one project to another (PConProj), 19. I intend to work on my physical readiness in the future as well (PConFut)

### *Procedure*

The measuring procedure was performed in a few steps. Phase 1, in April 2016, included a test group consisting of eight actors, some of which were young actors, second-year students at the Academy of Dramatic Art in Zagreb, while others were actors from the acting ensemble of *Gradsko kazalište mladih* from Split. Twenty days later, a retest was performed on the same sample. It was important to mention that during the first testing the subjects did not know that there would be another testing, whereas during the second testing they did not know that the first testing was going to be taken into account. To be more precise, the subjects were not introduced to any detail of the testing. The third round of testing was performed during May 2016 on a sample of 20 other actors and actresses who had been randomly selected, with different ages, sex and physical fitness taken into consideration.

### *Statistical analysis*

Reliability of newly constructed questionnaire was examined by using coefficient of correlation between test and retest (Dizdar, 2006). Questions with test-retest correlation coefficient below 0,60 were excluded from further analysis. With goal to identify latent structure of actors attitudes and habits, and to validate measuring instrument, factor analysis with varimax raw rotation was applied. Items that did not fit into any factor were excluded from further consideration. For each test, parameters of descriptive statistics had been calculated: arithmetic mean (AS), standard deviation ( $\sigma$ ), coefficient of variation (CV), median (Med), minimal and maximal value (Min and Max). This parameters were made for whole sample, and separately for males and

females. Normality of distribution was tested with Kolmogorov – Smirnov test. Test was used to determine the differences between males and females in all questions in questionnaire that had acceptable reliability, was tested. Type I error was set to 5%. All calculations were made in Statistica ver. 13.0.

### 3. Results and discussion

According to the results of the statistical calculation of the questionnaire, we came across some interesting research outcomes. It is important to emphasize that items of acceptable reliability and significance parameters were identified. Although not all questions were applicable and some lacked reliability, which was revealed by means of a reliability test, there was still enough material to make the basic conclusions and contemplate the goals. Furthermore, although a statistically significant difference between males and females in some of the questions was expected, it turned out that there was no difference. There were differences in some of the questions, but in general view there was none. In addition, we could claim that most actors stated that the 21<sup>st</sup> century presented a bigger challenge in terms of body preparation through fitness and recreation, more so than the 20<sup>th</sup> century (Meyerhold – Braun, 1995). In the end, a test was made to examine whether “Scene Movements” as a course during actors’ education was enough to prepare them for all acting challenges one may come across, such as presentation on the stage, self-confidence and physical durability, and that require hours of physical and mental work and are closely connected to fitness and recreation. The results have shown that the course satisfied women’s expectations more than men’s. However, neither were completely satisfied with what they were offered. To be more precise, the scene movement course at the Academy of Dramatic Art did not fulfill their need for physical activity. This conclusion, even though statistically correct, should not be taken into consideration without reserve, because we believe that the perception of the need for activity was not the same in both genders (Stanislavski, 1989a). However, this would be in the field of a different study. It was clear that their need, no matter the differences, was not satisfied.

Despite the general assumption that actors/actresses often, consciously or unconsciously, do sport activity or recreation to maintain some sort of physical fitness (Meyerhold – Braun, 1995), research has shown that actors who generally trained before, during and after their education were aware of the need to train, but were not satisfied with their current physical condition, to be more precise, their physical form (Findaly, 1997). In this case as well, we had to ask ourselves did it present real fitness. In fact, the question was whether those same actors indeed were out of shape, or could their standpoint about the

issue have been unrealistic due to the nature of their profession. The author's assumption had been that there would be those who would underestimate themselves, as well as those who would overestimate themselves in case of a measurable realistic state through, for instance, regular doctor's examination. It was interesting to note that females trained less, but were more satisfied with their current form. They also paid more attention to their colleagues' physical activity, fitness and appearance.

In future studies, attention should be pointed to what kinds of fitness and recreation activities actors do in terms of their workout, how much does exercise contribute to true physical fitness and how much to the aesthetics, and to what extent does workout affect the aesthetics. Where is the line between physical fitness, feeling "fit" and aesthetics for its own sake, if the border line between those two terms even exists?

**Table 1:** Descriptive statistics, testing of normality and also reliability testing of items (**AS** - arithmetic mean;  **$\sigma$**  - standard deviation; **CV%** - coefficient of variation; **Med** - median; **Min** - minimal result; **Max** - maximal result; **KS** - significance of Kolmogorov-Smirnov test)

	<b>AS<math>\pm</math><math>\sigma</math></b>	<b>CV%</b>	<b>Med</b>	<b>Min</b>	<b>Max</b>	<b>KS</b>	<b>R</b>
PA	3,80 $\pm$ 1,32	34,83	4,00	1,00	5,00	p <,05	0,68
PA15	3,80 $\pm$ 1,30	34,14	4,00	1,00	5,00	p <,10	0,96
IntsTrain	2,83 $\pm$ 1,34	47,34	3,00	1,00	5,00	p <,15	0,75
PFit+	3,43 $\pm$ 1,50	43,73	4,00	1,00	5,00	p <,15	0,91
FizForm+	2,93 $\pm$ 1,23	41,93	3,00	1,00	5,00	p >,20	0,84
PAColleg	3,37 $\pm$ 1,35	40,14	4,00	1,00	5,00	p <,05	0,70
ScenMovPA	2,77 $\pm$ 1,19	43,17	3,00	1,00	5,00	p <,15	0,80
PFtnsActsAchv	4,13 $\pm$ 1,14	27,50	4,00	1,00	5,00	p <,05	<b>0,27</b>
EdctPPrep	4,57 $\pm$ 0,68	14,87	5,00	3,00	5,00	p <,01	<b>0,16</b>
FnshEdctPPrep	4,67 $\pm$ 0,55	11,71	5,00	3,00	5,00	p <,01	<b>0,51</b>
EdctHealtFood	3,83 $\pm$ 1,39	36,30	4,00	1,00	5,00	p <,05	<b>0,57</b>
PR21st20st	4,40 $\pm$ 0,77	17,50	5,00	3,00	5,00	p <,01	<b>0,24</b>
TrainPFLook'16/'90	4,13 $\pm$ 0,82	19,82	4,00	2,00	5,00	p <,10	<b>0,29</b>
PLook21st	4,03 $\pm$ 1,10	27,22	4,00	2,00	5,00	p <,05	0,71
USALook	3,77 $\pm$ 1,36	36,01	4,00	1,00	5,00	p <,10	0,74
CollegPR	2,50 $\pm$ 0,78	31,07	3,00	1,00	4,00	p <,05	0,76
MyCollegPR	3,03 $\pm$ 1,03	34,07	3,00	1,00	5,00	p <,15	0,60
PConProj	4,07 $\pm$ 0,83	20,35	4,00	2,00	5,00	p <,10	<b>0,06</b>
PConFut	4,60 $\pm$ 0,67	14,67	5,00	2,00	5,00	p <,01	<b>0,45</b>

After a thorough analysis of the subjects, based on the results of the reliability analysis, questions from 8 to 13 as well as 18 and 19 were excluded from the questionnaire (Table 3). It was evident that the acting population indicated a training history (PA) and strong training habits for the preceding 15 days (PA15), but they were not satisfied with their current training habits (IntsTrain). The actors usually had three trainings per week over the preceding year, but they were not satisfied with their current fitness status (PFit+). It was clear that, being visual types, they paid attention to their colleagues' appearance, but not excessively (CollegPR). They were largely aware of the importance of physical preparation during and after education period (EdctPPrep). They believed that physical condition was important for acting achievements (PConProj). Finally, they intended to work on their physical fitness in the future (PConFut).

**Table 2:** Factor analysis results (Factor structure matrix).

	<b>F1</b>	<b>F2</b>	<b>F3</b>	<b>F4</b>
PA	-0,05	-0,02	0,11	<b>0,92</b>
PA15	<b>0,80</b>	0,07	0,06	0,08
IntsTrain	<b>0,82</b>	-0,16	0,11	-0,04
PA>3xWe	<b>0,74</b>	-0,26	0,12	-0,15
PFit+	<b>0,64</b>	-0,05	0,16	0,25
PAColleg	0,23	0,32	<b>0,75</b>	-0,14
ScenMovPA	-0,09	<b>0,87</b>	0,18	-0,08
PLook21st	<b>0,54</b>	0,40	-0,35	-0,11
CollegPR	-0,05	0,11	<b>-0,87</b>	-0,18
MyCollegPR	-0,19	<b>0,80</b>	-0,08	0,11
Variation	2,70	2,04	1,64	1,29
Proportion	0,25	0,19	0,15	0,12

With the help of a factor analysis we obtained four latent dimensions (Table 2). The first factor could be interpreted as the *form* factor. It is evident from the table that form was mentioned in all the variables that highly correlated with the extracted latent dimension. Primarily, the questions concerning



physical activity in last 15 days (PA15), in the past year (PA>3xWe), as well as to current training activity (IntsTrain) established a correlation of over 0.5. The second factor could be interpreted as the *physical appearance* factor. It was obvious that the term “physical” dominated the acting profession, sometimes in the aesthetic, and sometimes in the conditioning sense. However, there was nothing disputable about the emphasis on the physical aspect, and this work was aimed exactly to prove that the body had a role as an acting tool. The third factor could be interpreted as the *training habits* factor. It was obvious that training habits were generally the key to success toward physical fitness. Therefore, the training habits factor was absolutely logical in this questionnaire. In this case, it was about the frequency of training habits before, during and after education. The fourth factor was highly related to only one variable, and for that reason it was not interpreted. The item USA look was removed from further analysis.

Table 3 shows the results of t-test for dependent samples.

**Table 3:** T-test results(Mean of males - AS-M; Mean of females - AS-F; t – t value; p – level of significance; F-var - level of significance in testing of homogeneity of variances)

	AS-M	AS-F	t	p	F-var
PA	3,80	3,80	-0,00	1,00	0,66
PA15	3,87	3,73	0,28	0,78	0,69
IntsTrain	2,60	3,07	-0,95	0,35	0,96
PA>3xWe	3,13	3,73	-1,10	0,28	0,85
PFit+	3,00	2,87	0,29	0,77	0,75
PAColleg	3,40	3,33	0,13	0,90	0,87
ScenMovPA	3,07	2,47	1,40	0,17	0,49
PLook21st	4,33	3,73	1,53	0,14	0,52
CollegPR	2,67	2,33	1,18	0,25	0,66
MyCollegPR	3,40	2,67	2,05	0,05	0,01

Results of t-test were such that no significant difference between male and female answers in this questionnaire could be determined.

#### **4. Conclusions**

According to the results of the statistical calculation of the questionnaire, we came across some interesting research results – there was no significant difference between male and female Croatian actors with respect to their attitudes and habits toward fitness and recreation.

The results have shown that the scene movement class satisfied women's expectations more than men's. However, neither were completely satisfied with what they were offered. The scene movement course at the Academy of Dramatic Art did not fulfill their need for physical activity.

In future studies, attention should be pointed to what kinds of fitness and recreation activities actors do in terms of their workout, how much does exercise contribute to true physical fitness and how much to the aesthetics, and to what extent does workout affect the aesthetics.

#### **5. References**

1. Dizdar, D. (2006). Kvantitativne metode. Zagreb: Kineziološki fakultet.
2. Findaly R. (1997). Grotowski's Laboratory theatre. New York: Routledge.
3. Meyerhold – Braun E. (1995). A Revolution in Theatre. University of Iowa: Iowa City
4. Stanislavski K. S. (1989a). Rad glumca na sebi 1. Zagreb: Cekade
5. Stanislavski K.S. (1989b). Rad glumca na sebi 2. Zagreb: Cekade.
6. Stanislavski K.S. (1995). Moj život u umjetnosti. Sarajevo: Narodna prosvjeta.

#### **Author info**

*Corresponding author: [lucijana.krzelj@gmail.com](mailto:lucijana.krzelj@gmail.com)*

## Core stability in baseball

Marijan-Frane Tomašić, Jelena Paušić

*Faculty of Kinesiology, University of Split*

### Abstract

*The study was conducted on a sample of 45 children aged 14-15 years who were divided into a control and experimental group. The objective of the study was to determine the differences in the stability of the core / spine in the sitting position. Differences were determined by analysis of variance. Respondents who were in the control group showed better results in all stability tests.*

**Keywords:** *Baseball, stability, core, spine, asymmetry*

### 1. Introduction

Strength and core stability is very important for top performance of some elements and also to prevent injuries in almost every sport (Bouissets S., 1991), and stability of the core and pelvis are vital for motion of all extremities. A Baseball player needs to project enough energy and momentum in the whole kinetic chain so he could throw fast towards a specific location, like the strike zone, when pitcher throws to the batter. Without sufficient core strength baseball players cannot throw with maximum speed and then they risk injury. Since the whole kinetic chain of throwing is very complex, every segment needs to be well trained. While throwing the baseball, not just arms and shoulders muscles are included but also the trunk, pelvis, legs and center of gravity of the body. Not mastering one segment can lead to risk of injury. Therefore, there must be no "weak links" in the kinetic chain because otherwise it comes to unwanted strain on the shoulder joint which can lead to injury (Kathleen R. Lust, Michelle A. Sandrey, Sean M. Bulger and Nathan Wilde, 2009.). The most common segment that is neglected is the core strength and stability, which is by many standards most important part of the kinetic chain because it connects the lower extremities with the upper (Putnam, 1993). Body center gravity and core stability is the first step in mastering all baseball

elements, whether it comes to pitching, catching or hitting the ball. It is well known that baseball pitchers come up with asymmetry in the shoulders due to the constant loading of the throwing arm and shoulder, which eventually reach a lower position than the throwing side of the body, resulting in mild scoliosis (Tse et al., 2005). For proper posture and good balance while standing or in movement, an important role has the core muscles, that must produce muscle force and continuously maintain the movement's functionality. Core stability takes a leading role in sport, kinesitherapy and everyday life. Mechanic stability of the lumbar spine must be well maintained in every moment so it could prevent bending and eventual injuries when the spine is burdened during physical activity (Cholewicki et al., 1999). There are many ways to test stability on athletes, but in this paper we are trying to use a tenziometric platform called Footscan that is usually used on examines while standing up. In this paper, we evaluated the postural stability with the hip flexion test in the sitting position, which is the whole purpose of this paper. There are no known researchers of this type, so we are trying to see if we can use the Footscan platform for this purpose. The balance platform is as we know very expensive, so if the results show adequate results means that we can use the platform in other ways and not just in the standing position, which is very beneficial when using expensive equipment such as the Footscan platform.

## 2. Materials and methods

### *Participants*

The sample of test subjects was defined as a set of 45 male students aged 14-15 years old divided into a control (N=23) and experimental group (N=22). The experimental group consists of baseball players of the age 14-15 playing for the club Nada SM in Split Croatia. All players in the experimental group train together for about 5 years, three times a week. The control group is made up of students of the Technical High School of Split, which, unlike the experimental group, do only physical education, once a week for two school hours (90min). In addition to age, the condition for testing was that all subjects were clinically healthy and volunteered for testing.

### *Measurements*

The sample of variables in this study is a battery of 11 tests, of which 9 have been evaluated with a tensiometric Footscan platform and the variables are:

**S** – measuring while sitting on the platform, the distance of the body's central gravity point within the support surface of the platform expressed in millimeters, the average result for all three measurements.

**SD%** - The percentage of the body's central gravity point located on the right side of the body's center projection point while sitting on the platform, the average result for all three measurements.

**SL%** - The percentage of the body's central gravity point located on the left side of the body's center projection point while sitting on the platform, the average result for all three measurements.

**L** – elevating the left leg, the distance of the body's central gravity projection point within the support surface of the platform expressed in millimeters, the average result for all three measurements.

**LR%** - elevating the left leg, the percentage of the body's central gravity point located on the right side of the body's center projection point while sitting on the platform, the average result for all three measurements.

**LL%** - elevating the left leg, the percentage of the body's central gravity point located on the left side of the body's center projection point while sitting on the platform, the average result for all three measurements.

**R** - elevating the right leg, the distance of the body's central gravity projection point within the support surface of the platform expressed in millimeters, the average result for all three measurements.

**RR%** - elevating the right leg, the percentage of the body's central gravity point located on the right side of the body's center projection point while sitting on the platform, the average result for all three measurements.

**DRL%** - elevating the right leg, the percentage of the body's central gravity point located on the left side of the body's center projection point while sitting on the platform, the average result for all three measurements.

**ER** – elevating the reflected foot, the distance of the body's central gravity projection point within the support surface of the platform expressed in millimeters, the average result for all three measurements.

**ERR%** - elevating the reflected foot, the percentage of the body's central gravity point located on the right side of the body's center projection point while sitting on the platform, the average result for all three measurements.

**ERL%** - elevating the reflected foot, the percentage of the body's central gravity point located on the left side of the body's center projection point while sitting on the platform, the average result for all three measurements.

**ENR** – elevating the non-reflective foot, the distance of the body's central gravity projection point within the support surface of the platform expressed in millimeters, the average result for all three measurements.

**ENRR%** – elevating the non-reflective foot, the percentage of the body's central gravity point located on the right side of the body's center projection point while sitting on the platform, the average result for all three measurements.

**ENRL%** - elevating the non-reflective foot, the percentage of the body's central gravity point located on the left side of the body's center projection point while sitting on the platform, the average result for all three measurements.

By lifting the left and right leg we disrupted the body balance trying to compensate postural instability with coordinated muscular activation to achieve a good test performance. The examinee sits on the platform in a way that the feet would not touch the floor but would hang in the air. The posture was relaxed with arms resting on the thighs and the head looking in front. After that, we tested the examinees with the left or right leg raised. The raised leg would raise a little but not too much, enough to disturb the balance in the sitting position. Every test was measured for 20 seconds for three times. Value by which we evaluated postural stability is COF *Total travel way*, which represents the distance of the body's central gravity projection point while measuring on the Footscan.

To determine the postural stability, the percentage of the body's center of gravity in the seat position is distributed to the left and to the right from the projection point of the support surface of the examinee. The total percentage is 100%, and refers to the sum of the values of two variables % left and % right. In this way, the asymmetry of the body's position can be seen by performing the hip joint flex test while sitting on the platform, performing the testing three times. After we have determined the metric characteristics of the whole testing, we created a matrix with respect to the reflective leg of the examinee. Most of the respondents were right-handed, meaning that they had a refractory left leg (in most cases), so nothing was changed in the matrix, while the subjects

with a reflective right leg (left-handed subjects) we replaced the results in the following way.

S, SR%, SL% are the same for all subjects in the matrix. At right-handed examinees L and D were changed to ER and ENR, as their left leg is the reflective foot, then L is the reflective foot and R is the non-reflective foot.

For left-handed examinees, L and D have only replaced their seats because they have a reflective right foot, so D is a reflective leg, and L the non-reflective foot. Therefore, at left-handed examinees, ER is essentially D, and ENR is L.

### *Statistical analysis*

Data processing included calculation of basic descriptive and distributional statistical parameters such as arithmetic mean (AS), standard deviation (SD), minimal and maximal result values (Min, Max), coefficient of skewness ( $a_3$ ) and kurtosis ( $a_4$ ). Distribution normality test was conducted by Kolmogorov-Smirnov test on the significance level of  $p < 0.01$ . To determine the metrical characteristics of the whole testing we used Reliability and Item analysis. Differences between groups we conducted in two ways: based on the group they are a part of (control or experimental group) and based on the reflective foot of the examinee. To determine all the differences between the groups we used univariate analysis of variance (ANOVA). Data processing was done by Statistica (ver. 12) program.

### **3. Results and discussion**

Each measurement was repeated three times in duration for 20 seconds. From the table it is apparent that the metric characteristics of the testing are satisfactory and that the reliability of the measurement is high. In Table 2 and 3, the basic statistical parameters for each group in every variable are entered, as followed: mean (AS), standard deviation (SD), range of results, the minimum (MIN) and maximum (MAX) value of the results, the asymmetry coefficient curve ( $a^3$ ) and kurtosis curve ( $a^4$ ), the maximum difference between the received and expected cumulative frequency (MAXD). The values of the Kolmogorov-Smirnov test showed that all variables are normally distributed, and that we can proceed with further data processing.

**Table 1.** Metric characteristics of the variables

<b>VAR</b>	<b>AS</b>	<b>SD</b>	<b>C<math>\alpha</math></b>	<b>SBA<math>\alpha</math></b>
<b>S</b>	474,20	127,12	0,95	0,95
<b>SR%</b>	144,87	25,42	0,84	0,85
<b>SL%</b>	155,80	25,49	0,89	0,90
<b>L</b>	448,13	118,72	0,92	0,93
<b>LR%</b>	216,42	35,88	0,93	0,93
<b>LL%</b>	83,49	35,92	0,93	0,94
<b>R</b>	452,06	109,71	0,94	0,95
<b>RR%</b>	93,13	34,50	0,93	0,93
<b>RL%</b>	207,00	34,32	0,92	0,92

*Legend: AS- arithmetic mean, SD- standard deviation, C $\alpha$ - Cronbach Alfa coefficient, SBA $\alpha$ - Spearman Brown Alfa coefficient.*

**Table 2.** Descriptive statistics of the control group (N= 23).

<b>VAR</b>	<b>AS</b>	<b>MIN</b>	<b>MAX</b>	<b>SD</b>	<b>a3</b>	<b>a4</b>	<b>maxD</b>
<b>S</b>	123,96	69,00	156,00	21,56	-0,90	1,12	0,16
<b>SR%</b>	50,87	35,00	87,00	10,74	1,55	5,01	0,15
<b>SL%</b>	49,13	13,00	65,00	10,83	-1,51	4,76	0,16
<b>ER</b>	126,09	85,00	185,00	29,17	0,71	-0,32	0,18
<b>ERR%</b>	61,78	20,00	93,00	21,11	-0,33	-0,56	0,12
<b>ERL%</b>	38,04	7,00	80,00	21,25	0,33	-0,60	0,12
<b>ENR</b>	126,26	83,00	171,00	25,54	0,09	-0,76	0,09
<b>ENRR%</b>	43,09	20,00	91,00	19,08	0,96	0,09	0,17
<b>ENRL%</b>	56,83	9,00	80,00	19,05	-0,95	0,09	0,17

Test = 0,28

*Legend: AS – arithmetic mean; Min – minimal value of result; Max – maximal value of result; SD – standard deviation; Skew – coefficient of asymmetry, Kurt – coefficient of kurtosis; Max D – deviation between cumulative and theoretic proportions; K-S p – significance of Kolmogorov-Smirnov test of the normality of distribution.*



**Table 3.** Descriptive statistics of the experimental group (N= 22).

VAR	AS	MIN	MAX	SD	a3	a4	maxD
S	178,09	110,00	305,00	52,47	1,00	0,45	0,19
SR%	48,14	30,00	79,00	10,85	1,18	2,14	0,20
SL%	51,86	21,00	70,00	10,85	-1,18	2,14	0,20
ER	164,59	97,00	241,00	42,17	0,54	-0,78	0,15
ERR%	69,59	22,00	93,00	19,27	-1,10	0,70	0,18
ERL%	30,41	7,00	78,00	19,27	1,10	0,70	0,18
ENR	165,86	109,00	275,00	48,83	0,92	-0,38	0,22
ENRR%	35,95	10,00	86,00	19,26	0,91	0,54	0,17
ENRL%	63,95	14,00	90,00	19,18	-0,92	0,57	0,17

Test=0,29

*Legend: AS – arithmetic mean; Min – minimal value of result; Max – maximal value of result; SD – standard deviation; Skew – coefficient of asymmetry, Kurt – coefficient of kurtosis; Max D – deviation between cumulative and theoretic proportions; K-S p – significance of Kolmogorov-Smirnov test of the normality of distribution.*

**Table 4.** Univariate analysis of variance ANOVA, depending on group.

VAR	Control		Experimental		F	p
	AS	SD	AS	SD		
S	123,96	21,56	178,09	52,47	20,83	0,000
SR%	50,87	10,74	48,14	10,85	0,72	0,400
SL%	49,13	10,83	51,86	10,85	0,72	0,402
ER	126,09	29,17	164,54	42,17	12,79	0,001
ERR%	61,78	21,11	69,59	19,27	1,67	0,203
ERL%	38,04	21,25	30,41	19,27	1,59	0,214
ENR	126,26	25,54	165,86	48,83	11,77	0,001
ENRR%	43,09	19,08	35,95	19,26	1,56	0,219
ENRL%	56,83	19,05	63,95	19,18	1,56	0,218

*Legend: AS – arithmetic mean; SD – standard deviation; F- F-test, p- test of significance.*

**Table 5.** Univariate analysis of variance ANOVA, depending on the reflective foot.

VAR	Control		Experimental		F	p
	AS	SD	AS	SD		
S	146,92	42,52	164,44	66,61	0,96	0,332
SR%	49	11,35	51,67	8,17	0,44	0,512
SL%	51	11,40	48,33	8,17	0,43	0,514
ER	140,28	38,71	163,44	45,31	2,41	0,128
ERR%	73,14	13,92	35,44	12,61	54,60	0,000
ERL%	26,75	13,97	64,56	12,61	54,61	0,000
ENR	141,58	38,72	161,78	57,73	1,60	0,213
ENRR%	32,11	12,12	69,56	11,90	69,21	0,000
ENRL%	67,78	12,08	30,44	11,90	69,13	0,000

*Legend: AS – arithmetic mean; SD – standard deviation; F- F-test, p- test of significance.*

The table shows that the control group has better results in all body / spine stability tests, that is, their COF value passes a smaller path during the test. The reason for this may be as we have already said because of the body asymmetry that occurs with children that practice baseball (Tse et al., 2005). If you are right-handed it usually means that you are hitting from the right side and throwing with you right arm. Therefore, it is likely that after several years of baseball training it can come to higher strengthening of the dominant side than the non-dominant side of the body, which ultimately results in the retraction of postural muscle on the dominant side of the body, resulting in scoliosis. One of the factors that could alleviate this asymmetry is the athlete's core itself. According to Tse et al., the musculature of the trunk includes the muscles of the core and pelvis that are responsible for maintaining the stability of the spine and pelvis and are important for transferring energy from the larger torso to smaller extremities during many sports activities. It is theoretically believed that if the extremities are strong, and the trunk is weak, result will be less production of the athlete's strength itself and an ineffective movement structure.

Kibler et al. (2006) define the stability of the trunk as the ability to control the position and movement of the trunk through the pelvis to enable optimal

production, transfer and control of force and motion in relation to the ultimate outcome in integrated sports activities.

According to Panjabi (1992), trunk stability is achieved through the integration of active spinal stabilizers (muscles), passive stabilizers (spine), and neuronal controls that work together to control the common intervertebral range of movement to enable activities to be performed not only for sport but also for everyday life.

#### 4. Conclusions

The aim of this study was to analyze the differences in spine / trunk stability by performing a flexion test in the hip joints while sitting on the Foot Scan tenziometric plate. The results showed that the control group was much better in spine / trunk stability compared to the experimental group. As a reason, we have attributed to body asymmetries that occur in children that play baseball for a few years. A factor that would help baseball players improve the stability of the trunk and thus the spine itself is the strength of the core itself, which numerous scientific papers confirm that investigated the stability of the trunk and spine in baseball.

The results would be more likely to be different if it was an older population, because baseball players normally in there conditioning have a big focus on conditioning the core, which is essential for all the actions in baseball, such as hitting balls, throwing balls, running the bases and other activities in baseball. The research also shows that we can use the tenziometric platform in the seating position and not just while standing up.

#### 5. References

1. Escamilla, R. F., Fleisig, G. S., Yamashiro, K., Mikla, T., Dunning, R., Paulos, L., Andrews, J. R. (2010). Effects of a 4-week youth baseball conditioning program on throwing velocity. *Journal of Strength & Conditioning Research* 24(12):3247-54.
2. [Gray, R.](#) (2009). A Model of Motor Inhibition for a Complex Skill: Baseball Batting. [Journal of Experimental Psychology](#) 15 (2):91-105.
3. Hibbs AE, Thompson KG, French D, Wrigley A, Spears I. Optimizing performance by improving core stability and core strength. *Sports Medicine*. 2008;38(12):995–1008

4. Kibler WB, Press J, Sciascia A. The role of core stability in athletic function. *Sports Med.* 2006;36(3):189–198
5. Kibler WB. Biomechanical analysis of the shoulder during tennis activities. *Clin Sports Med.* 1996; 14:79–85
6. Lachowetz, T., Evon, J., Pastiglione, J. (1998). The Effect of an Upper Body Strength Program on Intercollegiate Baseball Throwing Velocity. *Journal of Strength & Conditioning Research* 12(2):116-119.
7. Lin, W. B., Tung, I. W., Chen, M. J., Chen, M. Y. (2011). An analysis of an optimal selection process for characteristics and technical performance of baseball pitchers. *Perceptual and Motor Skills* 113(1):300-310.
8. Panjabi M. The stabilizing system of the spine, part I: function, dysfunction, adaptation and enhancement. *J Spinal Disord.* 1992; 5:383–389
9. Putnam CA. Sequential motions of body segments in striking and throwing skills. *J Biomech.* 1993; 26:125–135
10. Sciascia, Aaron, Thigpen, Charles Namdari, Surena Baldwin, *Sports Medicine & Arthroscopy* [March 2012 - Volume 20 - Issue 1 - p 16–21](#)
11. TSE MA, McManus MA, Masters RS. Development and validation of a core endurance intervention program: Implications for performance in college age rowers. *J Strength and Conditioning Res.* 2005; 19:547–552

### Author Info

Marijan-Frane Tomašić, e-mail: [klokan14@yahoo.com](mailto:klokan14@yahoo.com)

# Correlates of change-of-direction speed and reactive agility in basketball; playing-position- vs. total-sample approaches

Miran Pehar<sup>1</sup>, Ivan Zeljko<sup>1</sup>, Damir Sekulić<sup>2</sup>

<sup>1</sup> University of Mostar, Faculty of Natural Sciences, Mathematics and Education,  
Mostar, Bosnia and Herzegovina

<sup>1</sup> Faculty of Kinesiology University of Split

## Abstract

*The aim of this study was to determine the associations between anthropometric variables and certain motor performances and different types of agility performances in professional basketball players. The sample comprised 101 basketball players (all males; height: 194.92±8.09 cm; body mass: 89.33±10.91 kg; 21.58±3.92 years of age) who competed at the highest national competitive level. The total sample was divided into frontcourt- (N = 50) and backcourt-players (BC; N = 51). The variables included body-mass, body-height, body-fat-percentage, broad-jump, countermovement jump, and visual-reaction-time, basketball-specific tests of reactive agility, and change of direction speed. Associations between variables were established separately for the total sample and separately for frontcourt- and backcourt-players. The results highlight the need for position-specific approach in defining predictors of performance qualities in basketball. Differential approach to training and conditioning agility in frontcourt and backcourt basketball players is warranted.*

**Keywords:** open skill agility; closed skill agility; predictors; performance

## 1. Introduction

Agility is important performance quality in basketball [1,2]. Specifically, non-reactive agility (i.e., pre-planned agility, closed-skill agility, change-of-direction speed – CODS) allows a player to outperform the opponent in situations when he/she is in position to pre-plan movement scenario. Reactive-agility (i.e., non-

planned agility, open-skill agility) is challenged in all situations when player has to react to external stimuli (i.e., the trajectory of the ball, the opponent's change of direction, etc.), and consequently change the direction [3]

Studies already identified predictors of CODS and reactive agility in basketball, but interestingly all reported correlates of CODS and reactive-agility for basketball players observed all players at the same time, and did not separate the players according to their playing position [1,2]. On the other hand, playing positions in basketball are highly diverse in terms of numerous fitness parameters [2]. Therefore, it is reasonable to suppose that when observing associations between certain predictors and agility in the total sample of basketball players, a strong confounding effect of playing position occurs.

This study aimed to determine the possible associations of anthropometric variables and certain conditioning indices (predictors) with different types of agility performances (criteria) in professional basketball players. Specifically, we examined associations between predictors and criteria while: (i) observing the total sample of participants and (ii) dividing players according to their playing position (with separate groups for frontcourt and backcourt players).

## 2. Materials and methods

### *Participants*

In this study, we tested 101 high-level male professional basketball players from Bosnia and Herzegovina (height:  $194.22 \pm 8.19$  cm; body mass:  $88.993 \pm 10.01$  kg;  $21.12 \pm 3.99$  years of age). At the time of testing (competitive season 2014-2015), the players were involved in the highest national competitive rank. The players were categorized as backcourt players ( $n = 50$ ) or frontcourt players ( $n=51$ ) by the team manager (coach).

### *Measurements*

The variables in this study included anthropometrics (body height, body mass percentage of body fat – BF%), jumping capacities (countermovement jump - CMJ, and standing broad jump - SBJ), visual reaction time – VRT, basketball specific CODS (BBCODS) and reactive-agility (BBAGIL), and playing positions. All variables were measured by procedures explained in details elsewhere and reliability of all tests was proven to be high [3,4]

### *Statistical analysis*

Kolmogorov-Smirnov tests identified all variables as normally distributed, and means and standard deviations are presented. The homoscedasticity was proven by Levene's test. Differences between frontcourt and backcourt players were determined using the independent t-test and further analyzed using a magnitude-based Cohen's effect size (ES) statistic with modified qualitative descriptors. The associations between variables were determined using Pearson's product moment correlation (Pearson's R). These calculations were performed separately (i) for the total sample of subjects, (ii) for frontcourt players and (iii) for backcourt players. A p-level of 95% was applied, and Statistica ver. 12.0 (Statsoft, Tulsa, OK) was used for all calculations.

### **3. Results and discussion**

The frontcourt players were significantly taller (ES: 2.12, 95%CI: 1.61-2.59, very large differences), heavier (1.59, 1.14-2.04, large differences), and had a larger BF% (0.40, 1.14-2.04, small differences) than the backcourt players. The backcourt players achieved significantly better results for BBCODS (0.55, 0.15-0.95, small differences), BBAGIL (0.41, 0.01-0.80, small differences), , and visual reaction time (0.49, 0.10-0.89, small differences) (Table 1).

When the total sample of players was considered (i.e., the players were not divided according to playing position), body height and BF% are significantly correlated to BBCODS ( $r: 0.29$  and  $0.29$ ,  $p < 0.01$ ) and BBAGIL ( $r: 0.24$  and  $0.23$ ,  $p = 0.02$ ), with poorer performance in taller and players with larger BF%. In frontcourt players body height and BFAT% negatively, while broad-jump positively influence BBCODS ( $r: 0.39$ ,  $0.32$ ,  $-0.41$ , all  $p < 0.01$ , respectively). Also, better BBAGIL is observed for those frontcourt players with faster visual reaction time ( $r: 0.34$ ,  $p < 0.01$ ) (Table 2).

Our findings of a significant association between the broad jump and the BBCODS in the total sample and the frontcourt players are consistent with previous studies that reported a positive influence of horizontal displacement capacities (i.e., sprint, broad jump, and triple jump) on pre-planned-agility in basketball players [1,2] . However, the fact that the broad jump was not associated with the BBCODS in backcourt players indicates the appropriateness of the experimental design of this study (i.e., studying the predictors of agility separately for different playing positions).

**Table 1.** Descriptive statistics (means  $\pm$  standard deviations) and differences between playing positions evidenced by Student's independent samples t-test and Effect Size differences (ES) with 95% confidence intervals (95%CI)

	Frontcourt players (n = 50)	Backcourt players (n = 51)	Student's t-test		Effect size	
			t value	p	d	95%CI
Body height (cm)	200.0 $\pm$ 5.6	188.2 $\pm$ 5.5	10.74	0.00	2.12	1.61-2.59
Body mass (kg)	95.2 $\pm$ 10.0	81.6 $\pm$ 6.3	7.94	0.00	1.59	1.14-2.04
Body fat (%)	9.6 $\pm$ 3.7	8.2 $\pm$ 2.8	2.01	0.05	0.40	0.02-0.81
BBCODS (s)	1.79 $\pm$ 0.17	1.71 $\pm$ 0.11	2.57	0.01	0.55	0.15-0.95
BBAGIL (s)	2.07 $\pm$ 0.16	2.01 $\pm$ 0.13	2.12	0.04	0.41	0.01-0.80
CMJ (cm)	44.5 $\pm$ 5.5	46.4 $\pm$ 6.0	-1.70	0.09	-0.32	-0.72-0.07
Broad jump (cm)	243.4 $\pm$ 23.3	246.9 $\pm$ 19.9	-0.83	0.41	-0.17	-0.56-0.23
Visual reaction time (s)	0.77 $\pm$ 0.15	0.70 $\pm$ 0.13	2.76	0.01	0.49	0.10-0.89

**LEGEND:** BBCODS – basketball specific change of direction test; BBAGIL – basketball specific reactive agility test; CMJ – countermovement jump

The anthropometric measures were significant predictors of reactive agility performance in the total sample, and the best BBAGIL performances were achieved by shorter and leaner participants. There is no doubt that this finding supports the dominance of backcourt players in the BBAGIL, which is evident in reported between-position differences. In short, backcourt players are significantly shorter (188 and 200 cm), have lower BF% (8.21 and 9.58 %), and achieve better BBAGIL results than frontcourt players (1.79 and 1.71 s, for backcourt and frontcourt players, respectively; see Table 1), and these position differences are generally in agreement with the findings of previous studies [2] However, the fact that body dimensions were not significantly associated with the BBAGIL for frontcourt or backcourt players again highlights the type of mistake that could occur if results are generalized on the basis of calculations performed for the total sample of players.

Visual reaction time was significantly related to non-planned agility, but only for frontcourt players. The background of this association is rather complex and requires a profound interpretation. Visual reaction time can be defined as the elapsed time between the presentation of a visual stimulus and the subsequent behavioral response. It actually represents the level of neuromuscular coordination, in which the body decodes visual stimuli that travel via afferent pathways [5]. However, in the well-trained male athletes of similar training status that participated in our study, the most important factor that determined their visual reaction time was body height. This body



dimension directly defines the length of the efferent pathways. Throughout the visual reaction testing, our subjects had to perform a quick vertical jump in response to visual stimuli. After the visual cortex recognized the stimuli, the efferent mechanisms had to reach the motor units responsible for performing the jump (i.e., the calf muscles). As a result, the taller the participant, the slower his reaction to visual stimuli. The fact that an association between visual reaction time and non-planned agility was found solely in the frontcourt players is actually a natural consequence of the greater variability of body height within this group of players compared with the group of backcourt players (ranges of 30 and 24 cm for the frontcourt and backcourt players, respectively).

**Table 2.** Pearson's Product Moment Correlations between observed variables (\* denotes statistical significance of  $p < 0.05$ )

		Body height	Body mass	Body fat %	BBCODS	BBAGIL	CMJ	Broad jump
Body mass	All players	0.80*						
	Frontcourt	0.63*						
	Backcourt	0.69*						
Body fat %	All players	-0.03	0.15					
	Frontcourt	-0.27	0.20					
	Backcourt	-0.12	-0.16					
BBCODS	All players	0.29*	0.17	0.29*				
	Frontcourt	0.39*	0.14	0.32*				
	Backcourt	0.18	-0.27	-0.03				
BBAGIL	All players	0.24*	0.12	0.23*	0.68*			
	Frontcourt	0.26*	0.06	0.20	0.76*			
	Backcourt	0.06	-0.23	0.24	0.51*			
CMJ	All players	0.04	-0.13	-0.16	-0.16	-0.01		
	Frontcourt	-0.06	-0.27	-0.24	-0.21	-0.10		
	Backcourt	0.50*	0.36*	-0.02	-0.05	0.17		
Broad jump	All players	0.09	-0.03	-0.46*	-0.38*	-0.19	0.57*	
	Frontcourt	-0.05	-0.23	-0.53*	-0.41*	-0.19	0.53*	
	Backcourt	0.49*	0.56*	-0.34*	-0.19	-0.20	0.63*	
Visual reaction time	All players	0.48*	0.46*	-0.05	0.08	0.03	0.15	0.13
	Frontcourt	0.56*	0.41*	-0.18	0.07	0.34*	0.17	0.09
	Backcourt	0.24	0.20	0.07	-0.12	-0.09	0.25	0.24

*LEGEND: BBCODS – basketball specific change of direction test; BBAGIL – basketball specific reactive agility test; CMJ – countermovement jump*

#### 4. Conclusions

In conclusion, when relationships between independent variables and agility criteria were calculated for the total sample, the regressions depicted differences between playing positions. Meanwhile, the true origin of the influence (i.e., the physiological and/or biomechanical basis of the associations between the predictors and criteria) that would be applicable in real sports settings was not identified. Therefore, in order to identify predictors of specific performances in sport, position specific approach is necessary.

#### 5. References

- [1] A. Delextrat, B Grosgeorge and F. Bieuzen, "Determinants of performance in a new test of planned agility for young elite basketball players". International journal of sports physiology and performance vol 10, **(2015)**, pp. 160-165.
- [2] N. Sisic, M. Jelacic, M. Pehar, M. Spasic, and D. Sekulic, "Agility performance in high-level junior basketball players; the predictive value of anthropometrics and power qualities". Journal of Sports Medicine and Physical Fitness, vol 56, **(2016)**, pp. 884-893.
- [3] D. Sekulic, M. Pehar, A. Krolo, M. Spasic, O. Uljevic, J. Calleja-Gonzalez, J. and T. Sattler, "Evaluation of basketball-specific agility; applicability of pre-planned and non-planned agility performances for differentiating playing positions and playing levels" Journal of Strength and Conditioning research **(2016)** e pub ahead of print
- [4] M Pehar, D. Sekulic, N. Sisic, M. Spasic, O. Uljevic, A. Krolo, Z. Milanovic, and T. Sattler, "Evaluation of different jumping tests in defining position-specific and performance-level differences in high level basketball players". Biology of sport, vol 34 **(2017)**, pp. 263-272.
- [5] M. Phomsoupha and G. Laffaye, "The science of badminton: Game characteristics, anthropometry, physiology, visual fitness and biomechanics". Sports medicine, vol 45 **(2015)** pp- 473-495.

#### Author Info

Corresponding author: Ivan Zeljko, [ivanzeljko79@gmail.com](mailto:ivanzeljko79@gmail.com)

## Postural stability in older community-dwelling adults from Split

Ana Lozina, Andrija Tomić, Gorana Adum

*Faculty of Kinesiology University of Split*

### Abstract

*The aim of the research was to examine postural stability in elder population with open and closed eyes. The research included 54 female and male older community-dwelling adults aged 65 to 90 from Split, Croatia without any significant visual or auditory damages, neurological diseases and barely used any medicines which influence sensory-motor functions. Participants stood on the platform of Footscan (RsScan, Inc. UK) for 30 seconds with opened eyes and after that with closed eyes for 30 seconds. With t-test for dependent samples analysed differences in postural sway between stability tests with opened eyes and closed eyes. The result of this study was show that vision is a significant factor in postural stability and that COFTOTAL had higher values in test with closed eyes.*

**Keywords:** *footscan, postural sway, visual contribution*

### 1. Introduction

Postural control consists of both postural steadiness associated with the ability to maintain balance during quiet standing, and postural stability that is associated with the response to the applied external stimuli and volitional postural movements (Prieto, 1996). Posture is center of mass, within specific boundaries of space (Lord et al., 2007). Postural stability is important because it keeps the balance between muscular forces and external forces and therefore, is influencing not only for sitting and standing but for performing complexed body movements without feeling any pain. Good posture requires strength and it also translates into less injury and healthier body (Karon, 2009.). There are balance impairments associated with aging. Age-related decline in the ability of the above systems to receive and integrate sensory information contributes

to poor balance in elder adults. As a result, the elderly are at an increased risk of falls. In fact, one in three adults aged 65 and over will fall each year.

Various injuries can affect postural stability. Ankle injuries can result in proprioceptive deficits and impaired postural control (Lubetzki & Kartin, 2010). Individuals with muscular weakness, the occult in stability, and decreased postural control are more susceptible to ankle injury than those with better postural control. Balance can also be negatively affected in a normal population through fatigue in musculature surrounding the ankles, knees and hips. Studies have found that muscle fatigue around the hips (gluteals and lumbar extensors) and knees have a greater effect on postural stability (Davidson et al., (2004). Postural stability is connected with balance which is crucial for elder people because of very high risk of falling and getting injured and that results in their disability for doing everyday's activities. For maintaining equilibrium position, activating and deactivating muscle groups that are responsible for particular movements is very important. The function of proprioceptors is decreasing with age but it is possible to slow the process of decreasing or even maintaining a level of function with proper training adjusted for specific age. The main thing in balance requires coordination of input from multiple sensory systems (Gribble & Hertel, 2004) including vestibular, somatosensory and visual systems.

Vestibular system provides information regarding the position of the head in relation to gravity and movements of the head. Somatosensory system: senses of proprioception and kinesthesia of joints, information about movement of the body segments on and around each other. Visual provides information about the body's postures and positions in relation to the surrounding environment. (Gray Cook, 2010.)

Therefore, the aim of this study was to investigate the influence of visual system on postural stability in older adults aged 65 to 90.

## 2. Materials and methods

### *Participants*

The research included 54 **older community-dwelling adults** aged 65 to 90 from Split, Croatia without any significant visual or auditory damages, neurological diseases and barely used any medicines which influence sensory-

motor functions. The inclusion criteria were that the subjects had to be aged 65 years or older, living independently in the community.

### *Measurements*

Various parameters based on the force plate output have been used to measure the stability during quiet standing. Pressure on plate was measured, and the center of pressure (COP) was calculated on the contact area. Resulting force reacting to the ground was calculated from pressure and contact area under both feet and this force is called Centre of Force (COF). For the assessment of postural stability parameters obtained with the tensiometric plate Footscan (RsScan, incorporated UK), 6 variables were measured: COF X, COF Y, COF TOTAL with open and closed eyes. COF X indicates the center of gravity of the body on the tenziometric plate in the medium - lateral axis. COF Y indicates movement of the center of gravity of the body on the anterior - posterior axis. COF TOTAL indicates the overall movement of the center of gravity by M-L and A-P axis while standing on a tenziometric plate.

### *Procedure*

Participants were evaluated on the platform of Footscan (RsScan, Inc. UK). They were tested under eyes-open and eyes-closed conditions. Participants were standing still with arms along and looking straight. Feet were positioned on the board parallel in participant's neutral position. They were instructed to stand on the plate for 30 seconds with opened eyes, after that with closed eyes for 30 seconds.

### *Statistical analysis*

The results of reference lines were entered into the matrix of data, which were subsequently processed in the statistical software Statistica 13.0. The results were analyzed by descriptive statistics and the following values were obtained: mean, standard deviation, minimum score, maximum score, range, skewness, kurtosis. Assessment of the normality of data was conducted with the Kolmogorov-Smirnov Test. With t-test for dependent samples analysed differences in postural sway between stability tests with opened eyes and closed eyes.

### 3. Results and discussion

Table 1. shows the results of descriptive statistical procedures for all measured variables.

**Table 1.** Descriptive statistics

Variable	Mean	Min	Max	Range	SD	Skew	Kurt	max D	K-S p
OE COFX	7,00	2,00	16,00	14,00	3,96	0,94	-0,11	0,156	p < ,15
OE COFY	10,67	3,00	32,00	29,00	6,05	1,80	4,18	0,172	p < ,10
OE COFTOTAL	160,41	93,00	330,00	237,00	55,97	1,04	0,50	0,154	p < ,20
CE COFX	7,09	2,00	17,00	15,00	4,02	0,86	-0,17	0,181	p < ,10
CE COFY	12,13	4,00	30,00	26,00	6,18	1,29	1,29	0,148	p < ,20
CE COFTOTAL	204,24	93,00	481,00	388,00	86,98	1,41	2,53	0,109	p > .20

COF - Centre of Force on FootScan, OE COFX - Open eyes postural stability COF X axis, OE COFY - Open eyes postural stability COF Y axis, OE COFTOTAL - Open eyes postural stability COF Total, CE COFX - Closed eyes postural stability COF X axis, CE COFY - Closed eyes postural stability COF Y axis, CE COFTOTAL - Closed eyes postural stability COF Total

The results of the K-S test (Table 1.) were show that all variables are distributed normal. Because of fact that all variables are normal distributed the parametric procedure of T-test for dependent samples was used to realize where differences are. Obtained values with close eyes are larger than the obtained values with open, e. g. CE COF X / OE COFX - Mean 7,09 / 7,00 ; Max 16,00 / 17,00; Range 15,00 / 14,00; SD 4,02 / 3,96 ; Kurt -0,17 / -0,11 ; max D 0,181 / 0,156. Than can especially be seen just comparing CE COFTOTAL and OE COFTOTAL, e. g. CE COFTOTAL / OE COFTOTAL – Mean 204,24 / 160,41; Max 481,00 / 330,00 ; Range 388,00 / 237,00 ; SD 86,98 / 55,97 ; Skew 1,41 / 1,04 ; Kurt 2,53 / 0,50 ; max D 0,109 / 0,154 .

Visual contribution to postural stability differences in postural sway between stability tests with opened eyes and closed eyes. With advancing age, there is a generalized reduction in visual functioning which has been associated with impaired postural stability and increased risk of falls (Lord and Menz, 2000).

According Ray et al. (2008) results indicate that restricted vision has a negative impact on overall postural stability and visually impaired individuals utilize greater use of hip strategy to maintain postural stability. Visual control had a significant effect on the COFTOTAL in all tested older adults. The result of this study showed that **vision** is a **significant** factor in **postural stability and** COFTOTAL had higher values in test with closed eyes.

**Table 2.** Differences in postural sway between stability tests with opened and closed eyes. T-test for dependent samples

Variables	Mean	SD	Diff.	Std.Dv. Diff.	t	df	p	Confidence Interval -95,000%	Confidence Interval +95,000%
OE COFX	7,000	3,962							
CE COFX	7,092	4,015	-0,093	4,034	-0,1687	53	0,866	-1,194	1,009
OE COFY	10,666	6,050							
CE COFY	12,129	6,176	-1,463	7,796	-1,3789	53	0,173	-3,591	0,665
OE COFTOTAL	160,407	55,961							
CE COFTOTAL	204,240	86,977	-43,833	81,453	-3,9545	53	0,0002	-66,066	-21,601

COF - Centre of Force on FootScan, OE COFX - Open eyes postural stability COF X axis, OE COFY - Open eyes postural stability COF Y axis, OE COFTOTAL - Open eyes postural stability COF Total, CE COFX - Closed eyes postural stability COF X axis, CE COFY - Closed eyes postural stability COF Y axis, CE COFTOTAL - Closed eyes postural stability COF Total

Obtained values with close eyes are larger than the obtained values with open, e. g CE COFTOTAL / OE COFTOTAL – Mean 204,240 / 160,407 ; SD 86,977 / 55,961.

Older people have been reported to rely on vision more than on other sensory systems for orientation and balance. They often find difficulties in maintaining balance when their eyes are closed, emphasizing the importance of vision when performing tasks requiring well-controlled balance. (Wolfson et al., 1992.) It is important to know this, in order to prevent possible problems. According to Horak (2006) sensory information from somatosensory, vestibular and visual systems is integrated, and the relative weights placed on each of these inputs are dependent on the goals of the movement task and the environmental context. Postural equilibrium involves the coordination of sensorimotor strategies to stabilise the body's centre of mass (CoM) during both self-initiated and externally triggered disturbances in postural stability (Horak, 2006)

#### 4. Conclusions

In this research we proved that visual system has an impact on postural stability in elder population. Closing the eyes causes movement of the body which increases the possibility of injuries. It is necessary to do balance and

stability exercises with elder populations and after some time determine how the program effects on postural stability. All of this is crucial to prevent falls, which can be critical in that age because of the recovery pace. In further research we would carry out a program of exercises in duration of 3 months for balance improvement and observed the impact it has on results with closed eyes.

## 5. References

1. Davidson, B. S., Madigan, M. L., & Nussbaum, M. A. (2004). Effects of lumbar extensor fatigue and fatigue rate on postural sway. *European journal of applied physiology*, 93(1-2), 183-189.
2. Gribble, P. A., & Hertel, J. (2004). Effect of lower-extremity muscle fatigue on postural control. *Archives of physical medicine and rehabilitation*, 85(4), 589-592.
3. Gray Cook. (2010.), *Movement:Functional Movement Systems*, pp.50.
4. Lord, S. R., & Menz, H. B. (2000). Visual contributions to postural stability in older adults. *Gerontology*, 46(6), 306-310.
5. Lord, S. R., Sherrington, C., Menz, H. B., & Close, J. C. (2007). *Falls in older people: risk factors and strategies for prevention*. Cambridge University Press.
6. Karter, K. (2009). *Balance Training: Stability Workouts for Core Strength and a Sculpted Body*. Ulysses Press.
7. Lubetzky-Vilnai, A., & Kartin, D. (2010). The effect of balance training on balance performance in individuals poststroke: a systematic review. *Journal of neurologic physical therapy*, 34(3), 127-137.
8. Prieto, T. E., Myklebust, J. B., Hoffmann, R. G., Lovett, E. G., & Myklebust, B. M. (1996). Measures of postural steadiness: differences between healthy young and elderly adults. *IEEE Transactions on biomedical engineering*, 43(9), 956-966.
9. Ray, C. T., Horvat, M., Croce, R., Mason, R. C., & Wolf, S. L. (2008). The impact of vision loss on postural stability and balance strategies in individuals with profound vision loss. *Gait & posture*, 28(1), 58-61.
10. L. Wolfson, R. Whipple, C.A. Derby. (1992.) .A dynamic posturography study of balance in healthy elderly, *Neurology*, 42 (11) , pp. (2069-2075)
11. Horak, F. B. (2006). Postural orientation and equilibrium: what do we need to know about neural control of balance to prevent falls?. *Age and ageing*, 35(suppl\_2), ii7-ii11.

## Author Info

Gorana Adum, e-mail: [gorana.adum94@gmail.com](mailto:gorana.adum94@gmail.com)



## Relations Between Some Anthropometric Characteristics and Motor Abilities in Soccer Players

Ante Jurić, Mario Tomljanović, Tea Bešlija

*Faculty of Kinesiology University of Split*

### **Abstract**

*This paper is aimed to determine the relationship between anthropometric characteristics and motor abilities of first league soccer players by applying four anthropometric measures (Body height, Body weight, Body fat and Muscle mass) and three motor test performed on the Opto Jump platform (Counter movement jump, Squat jump and Stiffness test) on the sample of 28 soccer players aged  $22,8 \pm 2,6$  years. The players were measured in the preseason. Pearsons coefficient was used to determine correlation between anthropometric characteristics and measured motor abilities. Revealed that in the manifest space between anthropometric characteristics and motor abilities there was no statistically significant relationship.*

**Keywords:** *morphology, explosive power, soccer, Opto jump*

### **1. Introduction**

Soccer as a game is developing very fast, increasing dynamic, tactical and technical demands. In order to move better and more efficient player has to improve motor abilities. Improving motor abilities bodies are changing its structure and characteristics. The positional role of a player is related to his physiological capacity and demands of position. Thus, midfield players and full-backs have highest maximal oxygen intakes. Midfield players tend to have the lowest muscle strength [4]. Morphological characteristics represent the biomechanical basis or factors that either stimulate or limit the performance of certain movement tasks. Morphological and functional changes in the professional soccer body tissues create special structures and functions of

the organic system in order to enhance the performance. Twenty-seven male soccer players were tested at the beginning of the 2003-2004 season. Body composition, vertical jump, speed, lower-body and total body power production, and estimated  $VO_2$ max were measured. Significant correlations were found between body composition and physical performance ranging from -0.38 to 0.61 for weight, vertical jump, speed, total body power and  $VO_2$ max. Body fat had a positive correlation with speed and a negative correlation with  $VO_2$ max [5]. Four hundred and seven athletic Tunisian children (218 boys and 189 girls) ranging from 7 to 13 were randomly selected. Morphological factors were the main predictive factors of jumping. They performed Squat jumps (SJ) and Counter movement jumps (CMJ) [1]. Aim of this study was to determine the relationship of antropometrics variables (Body height, Body weight, Body fat and Muscle mass) and motor abilities variables (Countermovement jump, Squat jump and Stiffness jumps) of professional soccer players aged  $22,8 \pm 2,6$  years.

## 2. Materials and methods

28 professional soccer players (11 defenders, 8 midfielders and 9 strikers) of the same team participated in anthropometric and motor abilities measures, aged  $22,8 \pm 2,6$  years; FC Hajduk. Data of all variables were collected in Institute of sport, Split.

**Table 1.** Anthropometric variables:

VARIABLE	EQUIPMENT
Body weight	Tanita BC-418
Body fat	Tanita BC-418
Muscle mass	Tanita BC-418
Body height	Anthropometer

**Table 2.** Motor ability variables:

TEST/name	TEST/ protocol
Counter movement jump	booth hands were on the hips does not allowing the swing. The depth of the „counter movement“ or „pre-stretch“ action is not defined, it depend on the athlete. During the flight it is essential that the athlete maintain extension in the hips, knees, and ankle joints.
Squat jump	athlete comes to 90° position (knee) and execute the jump with hands on the hips. During the flight it is essential that the athlete maintain extension in the hips, knees, and ankle joints.
Stiffness test	seven jumps (first is from box- height 30 cm) are performed in row with a straight knees.

Tanita is the weighing machine that measure body weight, body fat, body mass and hydration, all of the parameters can be seen in the absolute, relative and percentage values. Motor abilities variables are performed on Opto jump platform and software. All players did 3 attempts and it was considering the best one. The measurements are performed in the preseason period. Results are analyzed in „Statistica 13“ windows operating system. Normality of variables was tested with Kolmogorov-Smirnov test and all data was presented with means, standard deviations, medians, ranges, minimal and maximal results of all cases. Pearson’s coefficient was used to determine correlation between anthropometric characteristic and motor abilities.

### 3. Results and discussion

28 player included in measurement are covering all positions. Morphological variables (Body height, Body weight, Body fat and Muscle mass) shows some differences minimal and maximal results. Data of motor abilities variables (Countermovement jump, Squat jump and Stiffness jumps) are spread especially Stiffnes jumps (Table 3). There is correlation between some anthropometric (BH and BW; MM and BF) and motor variables between themselves, but results doesn’t show correlation between morphological and motor ability variables (Table 4).

**Table 3.** Descriptive statistics. Total number of responders (N), mean, median (Med), minimum (Min), range (Range), standard deviation (SD), Kolmogorov- Smirnov test (KS).

	N	Mean	Med	Min	Max	Range	SD	KS
BH	28	184,14	184,50	172,00	199,00	27,00	7,18	0,13
BW	28	79,55	78,15	69,10	95,82	26,70	7,13	0,13
BF	28	9,06	9,10	6,10	13,30	7,20	1,84	0,07
MM	28	87,55	87,75	80,80	91,20	10,40	2,57	0,14
CMJ	28	41,32	40,45	35,50	49,90	14,40	3,82	0,15
SJ	28	39,71	39,80	30,80	49,30	18,50	3,80	0,10
STIFF	28	34,84	35,10	23,70	51,00	27,30	5,67	0,08

LEGEND: BH- body height (cm), BW- body weight (kg), BF- body fat (%), MM- muscle mass (%), CMJ – counter movement jump (cm) , SJ – squat jump (cm), STIFF- stiffness test (cm).

**Table 4.** Correlation matrix. Relations between anthropometric characteristics and motor abilities. N=28,  $p < 0,05$

	BH	BW	BF	MM	CMJ	SJ	STIFF
BH	1,00	<b>0,84</b>	-0,01	0,19	-0,01	0,02	0,08
BW	<b>0,84</b>	1,00	0,29	-0,15	-0,12	-0,14	-0,10
BF	-0,01	0,29	1,00	<b>-0,48</b>	-0,08	0,03	-0,11
MM	0,19	-0,15	<b>-0,48</b>	1,00	0,07	0,01	0,03
CMJ	-0,01	-0,12	-0,08	0,07	1,00	<b>0,82</b>	<b>0,67</b>
SJ	0,02	-0,14	0,03	0,01	<b>0,82</b>	1,00	<b>0,52</b>
STIFF	0,08	-0,10	-0,11	0,03	<b>0,67</b>	<b>0,52</b>	1,00

LEGEND: BH- body height (cm), BW- body weight (kg), BF- body fat (%), MM- muscle mass (%), CMJ – counter movement jump (cm), SJ – squat jump (cm), STIFF- stiffness test (cm).

Correlations between Body height and Body weight, Body fat and Muscle mass are significant and they belong anthropometric characteristics variables. Motor abilities variables shows significant correlations between Counter movement jump and Squat jump; Counter movement jump and Stiffness; Squat jump and Stiffness. There are different research about this subject. Some research show no relationship between size, body mass index, body fat and the physical abilities considered (yo-yo intermittent recovery test, squat jump test, countermovement jump test, vertical-jump test, and repeated sprint ability) [2], while some other research showed high correlation between anthropometrics variables and jumps (CMJ- fat free mass, 0,68)[3].

#### 4. Conclusions

We found no significant correlation between sets of four anthropometric measures (Body weight, Body height, Muscle mass and Body fat) and three motoric jump manifestations (Counter movement jump, Squat jump and Stiffness test) performed on the Opto jump platform. There is significant correlation between anthropometric measures Body weight and height and Body fat and Muscle mass. Significant correlation is also found between Counter movement jump with Squat jump and Stiffness and Squat jump with Stiffness. Possible explanation why we didn't find any significant correlation is because the height of the jump depends on relative strength and measurement was taken at preseason period. Other possible reason is because

of small and homogen group of professional soccer players who already adapted their bodies to modern soccer requests so we see no big differences in body composition in this group. Next studies should involve both vertical and horizontal explosive strength manifestation tests and more participants, or repeated tests in the season.

## 5. References

1. Aouichaoui, C., Trabelsi, Y., Tabka, Z., Dogui, M., Richalet, J. P., & Bouhlef, E. (2014). Effect of Anthropometric Characteristics and Socio-Economic Status on Vertical Jumping Performances in Tunisian Athletic Children. *American Journal of Sports Science and Medicine*, 2(1), 6-16.
2. Moncef, C., Said, M., Olfa, N., & Dagbaji, G. (2012). Influence of morphological characteristics on physical and physiological performances of tunisian elite male handball players. *Asian journal of sports medicine*, 3(2), 74.
3. Perroni, F., Vetrano, M., Rainoldi, A., Guidetti, L., & Baldari, C. (2014). Relationship among explosive power, body fat, fat free mass and pubertal development in youth soccer players: a preliminary study. *Sport Sciences for Health*, 10(2), 67-73.
4. Reilly, T., Bangsbo, J., & Franks, A. (2000). Anthropometric and physiological predispositions for elite soccer. *Journal of sports sciences*, 18(9), 669-683.
5. Silvestre, R., West, C., Maresh, C. M., & Kraemer, W. J. (2006). *Journal of Strength and Conditioning Research*; Champaign. 20.1. 177-83.

## Author Info

Ante Jurić: [ante.juric@hajduk.hr](mailto:ante.juric@hajduk.hr)

## The application of the raising of the torso from a lying position test (MRSPTL) in 30 and 60 seconds in elementary school pupils

Tihomir Vidranski, Zvonimir Tomac, Petar Otković

Faculty of Education, University of Josip Juraj Strossmayer, Osijek

### Abstract

*The aim of this study was to determine the amount of correlation (common variance) between the MRSPTL (the raising of the torso from a lying position) test performed in 30 seconds and the same test performed in 60 seconds in 167 early school age pupils from the first to third grade, as well as exploring age and gender based differences. By analyzing the correlation between these tests, which were conducted in order to assess the relative repetitive strength of the torso in first-grade, second-grade and third-grade elementary school pupils, a statistically significant and extremely high correlation was established, both on the entire sample (Pearson  $r = 0.906$ ), in first-grade pupils (Pearson  $r = 0.895$ ), second-grade pupils (Pearson  $r = 0.948$ ) and third-grade pupils (Pearson  $r = 0.887$ ). This correlation does not depend on gender, and is high in both genders, being  $r = 0.905$  among boys and  $r = 0.887$  among girls. Since these two tests comprise more than 82 % (0.9062) of the common variability, it can be concluded that they share the intended object of measurement, i.e. that both tests estimate the relative repetitive strength of the torso in early school-age children. Using a post – hoc test based on the statistically significant differences, the results indicate that the 30-second test better differentiates the first-grade and second-grade elementary school pupils, while the 60-second test better differentiates the second-grade and third-grade elementary school pupils, which indicates they can be used in practice, for various purposes.*

**Keywords:** repetitive strength test, early school age, common variance

### 1. Introduction

Repetitive strength, as a form of strength manifestation, can be defined as the ability of long-lasting muscle work, i.e. the ability of long-lasting

(repeated) overpowering of different types of resistance. If we are dealing with the overpowering of external loads, then we are talking about absolute repetitive strength, while if we are dealing with the overpowering of our own body weight in multiple instances, then we are talking about relative repetitive strength (Neljak et al., 2011). There are a number of tests for the development of repetitive strength, such as the raising of the torso from a lying position, a shorter variant of the raising of the torso from a lying position, the squat test, as well as some recently designed tests (Oreb and Mikulić, 2006), which find their purpose in various applied areas of kinesiology. The test most commonly used to measure the relative repetitive strength in older schoolchildren (from fifth to eighth grade) is the raising of the torso from a lying position for 60 seconds (MRSPTL), whereas in the first four grades of elementary school, with younger schoolchildren, this test was not widely applied, one of the reasons being that its 60 second duration was considered inappropriate for children of that age. The existing professional knowledge argues that strength tests, and thus the testing of the aforementioned abilities, should not be carried out by applying maximum and submaximal loads, since some authors cite insufficient joint and ligament strength (Milanović, 2008). The working capacity of children is considerably different than that of adults, as their increased muscle metabolism causes them to get tired faster than adults (Drabik, 1996). Given all limiting factors in assessing the strength of early school-age children, and considering that some authors believe that activities which last up to 20 seconds belong to the anaerobic alactic endurance, while activities which last longer belong to the anaerobic lactic endurance (Wertheimer et al., 2017), the goal of this work is to determine a common amount of correlation (common variant) between the 30-second and the 60-second varieties of the MRSPTL test, in order to popularize the usage of the test in practice.

## 2. Materials and methods

### *Participants*

A sample of respondents included 167 first-grade, second-grade, and third-grade pupils from an elementary school in Zagreb. Out of the total number of pupils, 59 (28 male and 31 female pupils) were first-graders, 52 (25 male and 27 female pupils) were second-graders, while 56 (31 male and 25 female pupils) were in the third grade.

### *Measurements*

The sample of the variables consisted of two tests, the 60-second MRSPTL test to assess the relative repetitive strength of the torso, and the 30-second variation of that same test.

### *Procedure*

The testing was performed in the morning shift, in Physical Education classes. The MRSPTL test (the raising of the torso from a lying position) was conducted in the beginning of a class, after the pupils warmed-up and stretched, as per instructions by the author (Neljak et al. 2011). For the purpose of this research, the test was conducted once. The results of the 30-second MRSPTL test and the 60-second MRSPTL test were used.

### *Statistical analysis*

The basic descriptive parameters (the arithmetic mean and the standard deviation, the minimum and maximum score) were calculated for both variables. In order to determine the correlation between the variables in all three grades, as well as the entire sample, the Pearson correlation coefficient was used. In order to determine the differences by age, the univariate analysis of the variance was used, and if the level of F was significant, the post-hoc Fisher LSD test was used. The T-test for independent samples was used to determine differences by gender. The normality of the distribution was tested by the Kolmogorov – Smirnov test. The significance was tested at  $p = 0.05$  in all analyses.

## **3. Results and discussion**

The Kolmogorov Smirnov test showed that the normality of the distribution does not deviate significantly neither in the 60-second test ( $K-S d = 0.0057$ ,  $p = 0.20$ ) nor in the 30-second test ( $K-S d = 0.078$ ,  $p = 0.20$ ).

By analyzing the correlation between the two tests for assessing the repetitive strength of the torso in first-grade, second-grade, and third-grade elementary school pupils, a statistically significant and extremely high correlation was determined, both on the entire sample (Pearson  $r = 0.91$ ) and in first-grade pupils (Pearson  $r = 0.89$ ), second-grade pupils (Pearson  $r = 0.95$ )



and third-grade pupils (Pearson  $r = 0.89$ ). This correlation does not depend on gender, and is high in both genders, being  $r = 0.90$  in boys and  $r = 0.89$  in girls. Since these two tests comprise more than 82% (0.91) of common variance, it can be concluded that they share the intentional object of measurement, i.e. that both tests estimate the relative repetitive strength of the torso.

**Table 1:** The basic descriptive parameters of the first-grade, second-grade and third-grade pupils in the repetitive torso strength assessment test.

	Variable	N	Mean	SD	Min	Max
1. grade	30s	59,00	13,56	4,30	5,00	29,00
	60s	59,00	23,98	6,09	10,00	38,00
2. grade	30s	52,00	15,21	3,58	8,00	24,00
	60s	52,00	26,58	7,37	13,00	44,00
3. grade	30s	56,00	16,75	5,09	1,00	30,00
	60s	56,00	29,41	8,71	1,00	49,00

**Table 2:** The basic descriptive parameters and gender differences in the repetitive torso strength assessment test.

	Variable	N	N	Mean	SD	Mean	SD	t-value	df	p
		M	F	M	M	F	F			
All	30s	84,00	83,00	16,55	4,58	13,72	4,09	4,20	165,00	0,00
	60s	84,00	83,00	29,36	8,07	23,83	6,30	4,93	165,00	0,00
1. grade	30s	28,00	31,00	15,04	4,93	12,23	3,17	2,63	57,00	0,01
	60s	28,00	31,00	26,36	6,41	21,84	4,97	3,04	57,00	0,00
2. grade	30s	25,00	27,00	16,28	3,35	14,22	3,56	2,14	50,00	0,04
	60s	25,00	27,00	28,88	7,24	24,44	6,95	2,25	50,00	0,03
3. grade	30s	31,00	25,00	18,13	4,72	15,04	5,09	2,35	54,00	0,02
	60s	31,00	25,00	32,45	9,10	25,64	6,60	3,14	54,00	0,00

**Graph 1:** The results curve in the first grade, second grade and third grade pupils in the 60-second test.

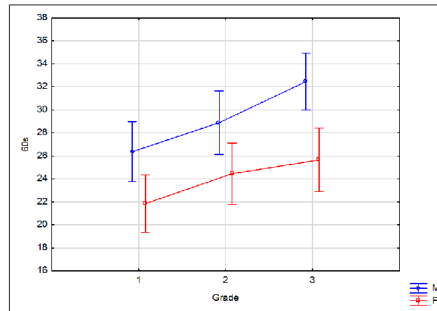

**Graph 2:** The results curve in the first grade, second grade, and third grade pupils in the 30-second test.

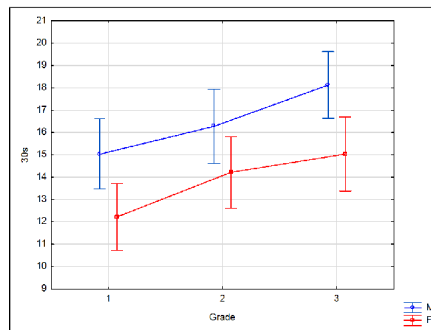

Table 2 shows there are statistically significant gender differences in repetitive strength assessment tests at each age. It can be concluded that by the time they enter school, boys already have more muscle strength than their female peers (Graphs 1 and 2). These strength differences among the genders are most often explained by different types of muscle fibers, although there is no evidence for the aforementioned differences in the distribution of muscle fibers (Šimek-Šalaj, 2008). Also, there are some indications that there are differences in the gradient of force between the genders, which could explain differences in strength (Komi and Karlsson, 1978; Ryushi et al., 1988). However, in the case of muscle biopsy, there is no evidence that the muscle fibers of individual muscles differ between men and women (Wilmore and Costill, 1977; Fleck and Kraemer, 1977). When the strength of individual muscles is expressed by body weight, fat-free mass or a muscle cross-section, the differences in strength decrease greatly or even disappear (Castro et al., 1995; Miller et al., 1993). Since there are differences in the values of the body

mass index increase, and hence the differences in body composition between male and female early school-age children (Neljak et al., 2011, Neljak, 2013), it can be assumed that these differences are also responsible for the obtained differences in relative repetitive strength between the genders.

Comparing the results by age, it is noticeable how muscle strength increases as a person grows up, i.e. there are statistically significant differences by age. That is in line with the research indicating that in the early school-age (from 7 to 9 years of age) the muscles, and thus the increase in all types of strength, develop slowly in both genders (Neljak, 2013). Thus the univariate analysis of the variant in the 60-second test found a statistically significant difference ( $F = 7.62, p = 0.00$ ) between the results of the first-graders, the second-graders and the third-graders (Table 2), as well as in the 30-second test (Table 2) ( $F = 7.64; p = 0.00$ ). The subsequent post – hoc test found that the results of the 60-second test among the third-grade pupils differ significantly from the results of the first-graders ( $p = 0.00$ ) and the second-graders ( $p = 0.04$ ), while the differences between the first-graders and second-graders are not statistically significant ( $p = 0.69$ ). This is in line with previous research, which indicates there is a difference in strength increase, manifesting mostly in larger muscle groups in the first and second grade, while the third and fourth grade are marked by growth due to the increase in strength and involvement of smaller muscle groups (Neljak, 2013). Also, it is most likely that among first-grade and second-grade children the anaerobic alactate energy reserves deplete in the first 20 seconds of the test, causing lower efficiency when performing the 60-second test, while in the 30-second test the entities can be better differentiated by the measurement item, the repetitive strength of the torso. This is confirmed by the results of the 30-second test, according to which there are significant differences between the first and second grade ( $p = 0.04$ ) and the first and third grade ( $p = 0.00$ ), while the differences between the second and third grade are not statistically significant ( $p = 0.07$ ).

#### 4. Conclusions

Based on the results of this research, it can be concluded that there are statistically significant gender differences in relative repetitive torso strength assessment tests among early school age children: by the time they enter school, boys already have more muscle strength than their female peers. By analyzing the correlation of the 30-second relative repetitive strength assessment test

and its 60-second variant between the first-grade, second-grade and third-grade elementary school pupils, a statistically significant and extremely high correlation was established, both on the entire sample (Pearson  $r = 0.91$ ) and between the grades, the latter of which does not depend on gender and is high in both genders. Overall, based on the results of this research, it can be concluded that the raising of the torso from a lying position (MRSPTL) test performed for a duration of 30 seconds and the same test performed in 60 seconds assess the same intentional object of measurement, i.e. the relative repetitive torso strength, and that the 30-second test better differentiates first and second-grade elementary school pupils, while the 60-second test better differentiates second and third-grade pupils. Knowing that, it is recommended that pupils in first and second grade use this test in 30 seconds, while for the pupils in third and fourth grade it is recommended to use this test in 60 seconds.

## 5. References

- [1] A. E. J. Miller, J. D. MacDougall, M. A. Tarnpolsky and D. G. Sale. Gender differences in strength and muscle fiber characteristics, *European Journal of Applied Physiology*, (1993), vol. 66, pp. 254-262.
- [2] B. Neljak, D. Novak, G. Sporiš, S. Visković and D. Markuš. Metodologija vrednovanja kinantopoloških obilježja učenika u tjelesnoj i zdravstvenoj kulturi – Cro fit norme, Gopal d.o.o., Zagreb, (2011).
- [3] B. Neljak. Kineziološka metodika u osnovnom i srednjem školstvu, Gopal d.o.o., Zagreb, (2013).
- [4] G. Oreb and P. Mikulić. Construction and validation of a single measuring instrument for estimating relative repetitive strength, 15th Summer school of Kinesiologists Republic of Croatia, (2006), pp. 180 - 186.
- [5] J. Drabik. Children and sports training, Stadion Publishing Company, Island Pond USA, (1996).
- [6] J. Wilmore and D. Costill. *Physiology of sport and exercise*. Human Kinetics, Champaign, IL, USA, (1997).
- [7] L. Milanović. "Strenght training for kids and young athelets – the most common doubts", 6th annual International conference Conditional preparation of athlets, Zagreb, Croatia, (2008), February 22-23.

- [8] M. J. Castro, D. J. McCann, J. D. Shaffrath and W. C. Adams. Peak torque per unit cross-sectional area differs between strength-trained and untrained young adults, *Medicine&Science in Sports&Exercise*, (1995), vol. 27, pp. 397-403.
- [9] P. V. Komi and J. Karlsson. Skeletal muscle fibre types, enzyme activities and physical performance in young males and females, *Acta Physiologica Scandinavica*, (1978), vol.103, pp. 210-218.
- [10] S. Šalaj. "Power and strength training for women", 6th annual International conference Conditional preparation of athletes, Zagreb, Croatia, (2008), february 22-23.
- [11] T. Ryushi, K. Hakkinen, H. Kauhanen and P. V. Komi. Muscle fiber characteristics, muscle cross-sectional area and force production in strength athletes, physically active males and females. *Scandinavian Journal of Sports Science*, (1988), vol. 10, pp. 7-15.
- [12] V. Wertheimer, I. Szabo and L. Leskovar. "Konkurentni trening jakosti i izdržljivosti", 15. Godišnja međunarodna konferencija Kondicijska priprema sportaša", Zagreb, Croatia, (2017), february 24-25.
- [13] W. Fleck and S. Kraemer. *Designing resistance training programs*, Human Kinetics, Champaign, IL USA (1997).

### Author Info

Corresponding author: Petar Otković, [potkovic@foozos.hr](mailto:potkovic@foozos.hr)

## Using of GPS in football match

Jakov Previšić, Tea Bešlija, Mario Tomljanović,  
Ante Jurić, Ivan Ćuković, Marko Lozančić

*Faculty of Kinesiology University of Split*

### Abstract

**G**PS wearable technology is being used in soccer to monitor how athletes train, perform and recover. Also, by controlling the player load it could possibly indicate injury or movement dysfunction. The aim of this paper was to determine whether there are relative differences in percentages in external load parameters (total distance, distance between 21-24 km/h, distance above 24 km/h, number of sprints between 21-24 km/h and number of sprints above 24 km/h) among various player's positions in elite soccer players from Croatian club (1.HNL) and football players of three European leagues (French league, Spanish league and German league). The sample consists of 5022 football players of 3 European leagues in one and 18 football players from Croatian 1<sup>st</sup> division club in second group. Data for first group was collected from 140 games while data for second group was collected from 40 games. Relative values have been used to determine differences in external load variables. Analysing the data we found significant differences between compared groups in favour of European clubs. Particularly regarding the amount of highest intensity zone run (>24 km/h) and the total amount of movement in higher velocity zones. From the viewpoint of strength and conditioning this information could be used as a guideline for further work with the group from HNL to get players performance to the level of European league clubs.

**Keywords:** GPS, football, external load, wearables

### 1. Introduction

Football, today the most popular sport, either from the aspect of number of visitors, tournaments or from the aspect of active athletes number. It belongs to a group of complex sports activities which is characterized by simple and

complexed movements of one or more athletes in competitive environment between individuals or teams (Milanović, Ostroški, Pišonić 2013). Because of the demands we give to football players, football game has improved; the bigger number of competitions, number of training days and training sessions, and the time for recovery between those is shorter and shorter. Systems of football game are progressing with the aim for individual tactical improvement and for the team improvement, the game is becoming more dynamic, aggressive and more attractive for fans. Competitions are becoming more demanding and by club responsibilities players have national team responsibilities. That kind of schedule competitions is also high demanding for players and coaches in the way of strength and conditioning, prevention, injuries, rehabilitation and regeneration.

Global positioning system (GPS) units are a satellite -based navigational technology which has been used profoundly in professional sports in past years since its introduction in 1997. (Schutz and Chambaz 1997). The use of global positioning systems (GPS), or more appropriately named 'wearable technology', in high-performance sport is becoming increasingly popular. In recent years, the use of wearable technology in professional sports has become common practice, and is supplementing the physical development department's ability to monitor athletic performance and readiness. In most circumstances, sport scientists monitor the following metrics and produce reports on a daily and/or weekly basis. Primary metrics are: total distance, high intensity distance, number of sprints, number of accelerations and decelerations, player load, collisions, number of jumps.

This technology is currently being used to provide sport scientists, strength and conditioning specialists, performance analysts, and coaches with real-time and post-match analysis of the athlete(s) practice or competition-based performances.

The aim of this paper was to determine relative values of external load parameters by every position: attacker, winger, midfielder, full back, central defender. External load parameters were: total distance, distance between 21-24 km/h, distance above 24 km/h, number of sprints between 21-24 km/h, number of sprints above 24 km/h in elite soccer players from Croatian club (1.HNL) and football players of three European leagues (French league, Spanish league and German league).

## 2. Materials and methods

The sample consists of 5022 football players of 3 European leagues in one group (attackers 724, central midfielders 1432, wide midfielders 50, full backs 132 and central defenders 1704) and 18 football players from Croatian league club in second group (attackers 3, central midfielders 5, wide midfielders 3, full backs 3, central defenders 4). Data from first group was collected from 140 games while data from second group consisted from 40 games was downloaded from newsletter (Shterjovski 2012). The measurement data was only from the players who played full match. GPS system which was used was Catapult, from Australian company, made in 2006. with software which allows real time collecting and processing data. Players had GPS device on their back in a vest under the shirt, S5 model, 15 Hz frequency. Relative values of results were determined in data processing methods.

## 3. Results and discussion

**Table 1.** Arithmetic means by positions Group 1

	Total distance	21-24	24+	SP 21-24	SP 24+
ATTACKER	10413	339	235	25	13
C.DEFENDER	10063	202	119	16	6
MIDFIELDER	11083	227	109	16	5
FULL BACK	10390	308	303	23	14
WINGER	10272	357	296	26	16

Note: Group – Croatian club 1.HNL, 21-24 - total distance between 21-24 km/h, 24+ - total distance above 24 km/h, SP 21-24 – number of sprint in zone 21-24 km/h, SP 24+ - number of sprints above 24 km/h.

**Table 2.** Arithmetic means by positions Group 2 (Shterjovski 2012)

	Total distance	21-24	24+	SP 21-24	SP 24+
ATTACKER	10979	325	325	23	14
C.DEFENDER	10116	325	173	23	14
MIDFIELDER	11563	325	211	23	14
FULL BACK	10898	364	330	26	16
WINGER	11366	364	355	26	16

Note: Group 2 – Europe, 21-24 - total distance between 21-24 km/h, 24+ - total distance above 24 km/h, SP 21-24 – number of sprint in zone 21-24 km/h, SP 24+ - number of sprints above 24 km/h.



**Table 3.** Relative differences in percentages in total distances and number of sprints amongst 1.HNL players and players of 3 European leagues

	AM Group 1	AM Group 2	Difference in percentage
Total Distance	10444,20	11577	-9,8%
21-24	286,60	340,60	-15,8%
24+	212,40	273	-22,2%
SP 21-24	21,20	24,20	-12,4%
SP 24+	10,80	14,80	-27,02%

Note: AM group 1 – arithmetic means of Croatian club in 1.HNL, AM Group 2 – arithmetic means of European clubs, Difference in percentage – relative differences by each zone amongst Croatian club in 1.HNL and European clubs, 21-24 - total distance between 21-24 km/h, 24+ - total distance above 24 km/h, SP 21-24 – number of sprint in zone 21-24 km/h, SP 24+ - number of sprints above 24 km/h.

In table 3 were shown average results of the players from Croatian club and players from European leagues in variables: total distance, distance between 21-24 km/h, distance above 24 km/h, number of sprints between 21-24 km/h and number of sprints above 24 km/h. Results showed that European league players ran 9,4% more in average during the match. Interesting part was that European league players ran 15,8% more in zone 21-24 km/h, and 22,2% more meters in zone above 24 km/h. Also, European players had 12,4% more sprints in 21-24 km/h zone and 27,02% more sprints above 24 km/h zone. Although high level and high quality players ran more, conclusion is that they ran more in high intensity distance zones (>21 km/h). Furthermore, we can see they had more sprints and more meters per sprint than analyzed club from Croatian league.

**Table 4.** Relative differences in percentages in total distances and number of sprints amongst 1.HNL attackers and attackers of 3 European leagues

	AM Group 1	AM Group 2	Difference in percentage
Total distance	10413	10979	-5,1%
21-24	339	325	+ 4,3%
24+	235	325	-27,7 %
SP 21-24	25	23	+8,6%
SP 24+	13	14	-7,1%

Note: AM group 1 – arithmetic means of Croatian club in 1.HNL attackers, AM Group 2 – arithmetic means of European clubs attackers, Difference in percentage – relative differences by each zone amongst Croatian club in 1.HNL and European clubs (attackers), TOT DIST- total distance, 21-24 - total distance between 21-24 km/h, 24+ - total distance above 24 km/h, SP 21-24 – number of sprint in zone 21-24 km/h, SP 24+ - number of sprints above 24 km/h.

In table 4 were shown average results of the attackers from Croatian club and attackers from European leagues in variables: total distance, distance between 21-24 km/h, distance above 24 km/h, number of sprints between 21-24 km/h and number of sprints above 24 km/h. Results showed that European league attackers ran 5,1% more meters then Croatian attackers. Interesting thing is that Croatian attackers ran more meters and had more sprints in 21-24 km/h zone (4,3% and 8,6%). From the previous results we can assume that in the moments of high intensive parts of the game European players manage to spend most of the time in high speed zones (>24 km/h), while lower quality players can't spend that much time in high zones and they work more in zones of lower intensity (21-24 km/h).

**Table 5.** Relative differences in percentages in total distances and number of sprints amongst 1.HNL central defenders and central defenders of 3 European leagues

	AM Group 1	AM Group 2	Difference in percentage
Total distance	10063	10116	-0,5%
21-24	202	325	-37,8%
24+	119	173	-31,2%
SP 21-24	16	23	-30,4%
SP 24+	6	14	-57,1%

Note: AM group 1 – arithmetic means of Croatian club in 1.HNL central defenders, AM Group 2 – arithmetic means of European clubs central defenders, Difference in percentage – relative differences by each zone amongst Croatian club in 1.HNL and European clubs (central defenders), 21-24 - total distance between 21-24 km/h, 24+ - total distance above 24 km/h, SP 21-24 – number of sprint in zone 21-24 km/h, SP 24+ - number of sprints above 24 km/h.

In table 5 were showed average results of the central defenders from Croatian club and central defenders from European leagues in variables: total distance, distance between 21-24 km/h, distance above 24 km/h, number of sprints between 21-24 km/h and number of sprints above 24 km/h. Results showed that European defenders run just little bit more (0,5%), but dominantly they spend more time in higher zones (>21 km/h). In average they run 37,8% more meters in zone between 21-24 km/h, and they do 30,4% more sprints. The biggest gap is in the highest zone of intensity (>24 km/h). In average central defenders of European clubs run 31,2 % more meters per game than

central defenders from Croatian club and they have 57,1% sprints in zone above 24 km/h. We can assume that football game in top level European clubs is more dynamic and modern football is mostly about fast transitions, although the both groups defenders run similar, European defenders because of the intensity of the match manage to run more in high intensity zones.

**Table 6.** Relative differences in percentages in total distances and number of sprints amongst 1.HNL midfielders and midfielders of 3 European leagues

	AM Group 1	AM Group 2	Difference in percentage
Total distance	11083	11563	-4,2%
21-24	227	325	-30,1%
24+	109	211	-48,3%
SP 21-24	16	23	-30,4%
SP 24+	5	14	-64%

AM group 1 – arithmetic means of Croatian club in 1.HNL midfielders, AM Group 2 – arithmetic means of European clubs midfielders, Difference in percentage – relative differences by each zone amongst Croatian club in 1.HNL and European clubs (midfielders), 21-24 - total distance between 21-24 km/h, 24+ - total distance above 24 km/h, SP 21-24 – number of sprint in zone 21-24 km/h, SP 24+ - number of sprints above 24 km/h.

In table 6 were shown average results of the midfielders from Croatian club and midfielders from European leagues in variables: total distance, distance between 21-24 km/h, distance above 24 km/h, number of sprints between 21-24 km/h and number of sprints above 24 km/h. We can see that midfielders from Croatian club run 4,2% less meters per game in average than European players. Players from European leagues do 30,1% in higher intensity zones (21-24 km/h) and also have 30,4 % sprints. In the highest intensity zone they run 48,3% more meters and have 64% more sprints. There is a proportional increase of total distance and the number of sprints per zone amongst European and Croatian midfielders and it can be assumed that increase is happening because of the demand of bigger amount of sprints. The reasons could be in difference of dynamic of higher level game and bigger number of tasks in the game midfielders needs to accomplish in higher intensity.

**Table 7.** Relative differences in percentages in total distances and number of sprints amongst 1.HNL full backs and full backs of 3 European leagues

	AM Group 1	AM Group 2	Difference in percentage
Total distance	10390	10898	-4,7%
21-24	308	364	-15,4%
24+	303	330	-8,2%
SP 21-24	23	26	-11,5%
SP 24+	14	16	-12,5%

Notes: AM group 1 – arithmetic means of Croatian club in 1.HNL full backs, AM Group 2 – arithmetic means of European clubs full backs, Difference in percentage – relative differences by each zone amongst Croatian club in 1.HNL and European clubs (full backs), 21-24 - total distance between 21-24 km/h, 24+ - total distance above 24 km/h, SP 21-24 – number of sprint in zone 21-24 km/h, SP 24+ - number of sprints above 24 km/h.

In table 7 were showed average results of the full backs from Croatian club and full backs from European leagues in variables: total distance, distance between 21-24 km/h, distance above 24 km/h, number of sprints between 21-24 km/h and number of sprints above 24 km/h. We can see that full backs from European clubs run 4,7% more meters than players from Croatian club. The difference is more expressed if we observe just higher intensity zones (>21 km/h). Full backs of European leagues run 15,4% more meters and perform 11,5% sprints between 21 and 24 km/h. In the highest intensity zone (>24 km/h) they run 8,2% more meters and perform 12,5% more sprints. Conclusion can be that besides the total distance, the more important is total distance in high intensity. Also big role can play tactics of the match which is more specific for full backs. In some systems, in which you play without wingers, full backs need to press more high and therefore run back, but in some systems full backs can rely more on wingers.

**Table 8.** Relative differences in percentages in total distances and number of sprints amongst 1.HNL wingers and wingers of 3 European leagues

	AM Group 1	AM Group 2	Difference in percentage
Total distance	10272	11366	-9,6%
21-24	357	364	-1,9%
24+	296	355	-16,6%
SP 21-24	26	26	0 %
SP 24+	16	16	0 %

Notes: AM group 1 – arithmetic means of Croatian club in 1.HNL wingers, AM Group 2 – arithmetic means of European clubs wingers, Difference in percentage – relative differences by each zone amongst Croatian club in 1.HNL and European clubs (wingers), 21-24 - total distance between 21-24 km/h, 24+ - total distance above 24 km/h, SP 21-24 – number of sprint in zone 21-24 km/h, SP 24+ - number of sprints above 24 km/h.

In table 8 were shown average results of the wingers from Croatian club and wingers from European leagues in variables: total distance, distance between 21-24 km/h, distance above 24 km/h, number of sprints between 21-24 km/h and number of sprints above 24 km/h. We can see that wingers from European clubs run 9,6% more meters than players from Croatian club. Interesting thing is that the difference between total distance and number of sprints amongst European and Croatian wingers is almost the same (1,9% in advantage of European wingers and 0% in number of sprints). Total distance in the highest zone (>24 km/h) amongst European wingers and wingers from Croatian club is the biggest difference (16,6% more meters in advantage of European wingers). Interesting thing is that there is no difference in the number of sprints. We can assume that there is a need for longer sprints, while the number of sprints is not changing with the increase of distance.

#### 4. Conclusions

Analyzing this data we can confirm that movement analysis of running intensity amongst lower leagues and higher leagues players is important. Besides that, there is a great variability within players positions where every position have its own specific task in football play. We can see that almost every position from the 1. HNL club is lagging behind in amount of high intensity run, and every position in the highest intensity zone (>24 km/h). Except total distance, there is a need for higher number of sprints in particular zone in some particular playing positions, while the others have need of longer movements in specified zones. There can be many reasons for that. Some of them might be low level venues and low quality players. Today there is a lot of U18 players playing 1.HNL who were already skipping younger categories because of the need for playing with older colleagues. Some of them say that players without the ball play football of 90' and in the finishing rarely were 2-3 players. Also there is no expensive software they can see what are their pluses and minuses. Interesting data in 1.HNL is that average active match duration is 40 minutes, so ball is outside of the game for 50 minutes in average during one football match, which means that football game is too slow.

This could be guidelines for further work for the group from 1.HNL with the aim to get players who could parry to European football league, of course from the conditioning point of view where we can talk about external load parameters included in football game.

In the end we can conclude that using GPS can make training individualization a lot easier, either in comparing with the best clubs and also as intern application in relation to your own players and their specific playing positions.

## 5. References

- [20] Milanović, D, Ostroški, S, Pišonić J.(2013). "Individualizirani pristup kondicijskom treningu u nogometu", pp. 561-566.
- [21] Schutz, Y, Chambaz, A. (1997)."Could a satellite-based navigation system (GPS) be used to asses the physical activity of individuals on earth?", Eur J Clin Nutr, pp. 51: 338-339.
- [22] Shterjovski, Z. (2012). "Small-sided games and integrating physical preparation", pp. 29-34.
- [23] Owen Walker (2017, January 27). [GPS Technology \(Wearables\)](https://www.scienceforsport.com/gps-wearables-part-1-technology-validity-and-reliability3/) part 1 [Article] Retrieved from <https://www.scienceforsport.com/gps-wearables-part-1-technology-validity-and-reliability3/>
- [24] Owen Walker (2017, January 27). [GPS Technology \(Wearables\)](https://www.scienceforsport.com/gps-wearables-metrics-and-application/) part 2 [Article] Retrieved from <https://www.scienceforsport.com/gps-wearables-metrics-and-application/>

## Author Info

*Corresponding author: jakovprevisic@yahoo.com*

# Preferences of high school students regarding enrollment at the Faculty of Kinesiology and other programmes of the University of Split

Adriana Češnik

*Faculty of Kinesiology, University of Split*

## Abstract

*The aim of this study was to determine the level of interest of high school students to enroll at the programmes of the University of Split, with special review of their interest to enroll at the undergraduate study of kinesiology, as well as to determine possible gender differences.*

*The convenience sample included 364 subjects of both genders (232 female and 132 male students), senior high school students from grammar schools in 3 Croatian cities/towns*

*The variable sample was defined by two items of the anonymous Questionnaire of study preferences for high school students: desirability of studying at a faculty, and desirability of realizing a working (business) career after successfully finishing the study.*

*Enrollment at the Undergraduate study of kinesiology, as well as Desirability of realizing a business career at the same study, holds the central position regarding the preferences of future students, senior students of grammar schools.*

**Key words:** *undergraduate study of kinesiology, questionnaire, business career*

## 1. Introduction

For the enrollment of students at the first year in 2017/2018, University of Split (2017) announced a public call for admission of 4 644 students in the undergraduate or integrated programme. Each programme at this University is trying to recruit the best possible high school graduates who are expected to finish the study successfully. In the attempt of successful selection of

high school students, faculties often set additional criteria for admission or implement additional entrance exams. Faculty of Kinesiology also has an admission classification procedure which includes testing of the health status and testing of motor abilities with a set threshold as the elimination criterion for each motor ability.

It would be reasonable to assume that the attitudes about the significance and 'desirability' of each faculty in adolescents are developed in accordance with their personal interests, previous high school achievements, but also under the influence of their narrow and broad sociocultural environment.

The aim of this study was to determine the level of interest of high school students to enroll at the programmes of the University of Split, with special review of their interest to enroll at the undergraduate study of kinesiology, as well as to determine possible gender differences.

## 2. Materials and methods

The convenience sample included 364 subjects of both genders (232 female and 132 male students), senior high school students from grammar schools in 3 Croatian cities/towns (Zadar-95; Trilj-80; Đakovo-189).

The variable sample was defined by two items of the anonymous *Questionnaire of study preferences for high school students* (Grgantov, Milavic, and Milic, 2016): desirability of studying at a faculty, and desirability of realizing a working (business) career after successfully finishing the study.

Data gathering was announced beforehand, approved by parents of underage students, school boards and school principals, and the students expressed their attitudes voluntarily in a group setting of their classroom.

Methods of data analysis included the calculation of descriptive indicators (mean and standard deviation) of the applied variables, range of results and application of the independent samples *T-test* to determine the gender differences between the groups.

## 3. Results and Discussion

Reliability of the measuring instruments indicates the amount of error of the measuring instrument and provides information on whether the final result shows the "real" state of the subjects. Reliability of the measuring instruments



was analysed based on the matrix of item intercorrelations. Average inter-item correlation and Cronbach's alpha coefficient were also calculated (Table 1).

**Table 1.** Preferences of high school students for enrollment at the study and realization of career

	Desirability of the study		Desirability of the career	
	M	SD	M	SD
Faculty of Civil Engineering, Architecture and Geodesy	2.93	1.41	3.23	1.43
University Department for Forensic Sciences	2.90	1.40	3.14	1.38
School of Medicine	2.87	1.44	3.51	1.61
University Department of Health Studies	2.83	1.42	3.03	1.45
Faculty of Electrical Engineering, Mechanical Engineering and Naval Architecture	2.72	1.50	3.08	1.53
Faculty of Humanities and Social Sciences	2.56	1.47	2.49	1.37
Faculty of Science	2.50	1.45	2.81	1.53
Faculty of Kinesiology	2.43	1.37	2.53	1.35
Faculty of Chemistry and Technology	2.24	1.29	2.52	1.38
University Department of Professional Studies	2.19	1.20	2.34	1.24
Faculty of Law	2.15	1.25	2.38	1.32
Academy of Arts	2.02	1.31	2.09	1.35
Faculty of Maritime Studies	1.99	1.25	2.23	1.34
Faculty of Economics	1.89	1.15	1.93	1.14
University Department of Marine Studies	1.88	1.12	1.98	1.17
Faculty of Catholic Theology	1.70	1.12	1.87	1.19
Faculty of Mediterranean Agriculture	1.68	0.98	1.76	1.03

**Legend:** M - mean, SD - standard deviation

The results of the variable *Desirability of enrollment at the study* are ranged from the highest to the lowest values in Table 1. Out of the 17 programmes, enrollment at the Undergraduate study of kinesiology lies at the 8th range, with the mean of 2.43, i.e., it holds the central position according to desirability of the study. The three most desirable studies (but also most desirable for *Realization of business career* after finishing the study) are as follows: Faculty of civil engineering, architecture, and geodesy with the mean value of 2.93; University department for forensic sciences with the mean value of 2.90, and School of medicine with the mean value of 2.87.

The results of the variable *Desirability of realizing a business career* show that, out of the 17 programmes at the University of Split, enrollment at the Undergraduate study of kinesiology lies at the 7th range, with the mean value of 2.53, which is also the central position according to the desirability of realizing a business career.

The values of the variable *Desirability of realizing a business career* are somewhat higher than the values of *Desirability of enrollment at the study*.

**Table 2.** Gender differences of preferences of high school students for enrollment at the study and realization of career after the study

	M F	SD F	M M	SD M	t- value	p	N F	N M
<b>Desirability of the study enrollment</b>								
University Department of Health Studies	3.15	1.40	2.27	1.28	5.98	0.00	232	132
School of Medicine	3.08	1.43	2.49	1.39	3.79	0.00	232	132
University Department for Forensic Sciences	3.07	1.37	2.60	1.39	3.16	0.00	232	132
Faculty of Humanities and Social Sciences	2.87	1.47	2.01	1.30	5.62	0.00	232	132
Faculty of Law	2.31	1.28	1.89	1.15	3.12	0.00	232	132
Academy of Arts	2.25	1.36	1.63	1.11	4.44	0.00	232	132
Faculty of Electrical Engineering, Mechanical Engineering and Naval Architecture	2.38	1.41	3.32	1.48	-6.00	0.00	232	132
Faculty of Kinesiology	2.32	1.31	2.61	1.47	-1.95	0.05	232	132

Desirability of realizing a business career								
School of Medicine	3.81	1.48	2.98	1.69	4.88	0.00	232	132
University Department of Health Studies	3.41	1.41	2.38	1.29	6.87	0.00	232	132
University Department for Forensic Sciences	3.37	1.34	2.75	1.37	4.18	0.00	232	132
Faculty of Humanities and Social Sciences	2.76	1.37	2.01	1.24	5.23	0.00	232	132
Faculty of Chemistry and Technology	2.65	1.42	2.31	1.28	2.25	0.02	232	132
Faculty of Law	2.56	1.30	2.08	1.28	3.40	0.00	232	132
University Department of Professional Studies	2.44	1.22	2.17	1.27	2.06	0.04	232	132
Academy of Arts	2.28	1.36	1.76	1.26	3.65	0.00	232	132
Faculty of Electrical Engineering, Mechanical Engineering and Naval Architecture	2.92	1.53	3.36	1.49	-2.67	0.01	232	132
Faculty of Kinesiology	2.49	1.30	2.61	1.44	-0.86	0.39	232	132

Legend: **M** - mean, **SD** - standard deviation

Significant gender differences in the variables *Desirability of enrollment at the study* and *Desirability of realizing a business career* can be seen in Table 2. Regarding the *Desirability of enrollment at the study*, significant differences were found in 8 programmes, including the enrolment at the Undergraduate study of kinesiology with the level of significance of  $p=0.005$ , whereas in the variable *Desirability of realizing a business career*, significant gender differences were found in 8 programmes of the University of Split, but not in the Undergraduate study of kinesiology.

#### 4. Conclusion

*Enrollment at the Undergraduate study of kinesiology*, as well as *Desirability of realizing a business career* at the same study, holds the central position regarding the preferences of future students, senior students of grammar schools. It is recommended for the measuring of preferences to be repeated

in the Split-Dalmatia County and the activities in the area of *public relations* should be targeted and planned in order to appeal to senior students of high academic quality to enroll at the Faculty of Kinesiology.

The limitations of this paper refer to: the convenience sample which does not necessarily „gravitate“ towards the University of Split; the sample that may have included high school students that do not wish to study at all; and a small number of personal variables (only gender).

## 5. References

1. Grgantov, Z., Milavic, B., & Milic, M. (2016). *Upitnik preferencije studija za učenike srednjih škola* (nepublicirani radni materijal). Split: Kineziološki fakultet. [*Questionnaire of study preference for high school students* (unpublished material). Split: Faculty of Kinesiology].
2. Sveučilište u Splitu. (2017). Natječaj za upis studenata u I. godinu preddiplomskog sveučilišnog, integriranog preddiplomskog i diplomskog sveučilišnog te preddiplomskog stručnog studija u akademskoj godini 2017./2018.

Retrieved 12th June 2017 from <http://www.unist.hr/Portals/0/docs/nastava/Natjecaj%20za%20upis%20studenata%20ak%20god%2017%2018.pdf?ver=2017-05-22-090235-410>.

## Author Info

Adriana Češnik

email: [adriana.cesnik@gmail.com](mailto:adriana.cesnik@gmail.com)

## Metric characteristics of some agility tests on sand surface

Daniela Dimlić, Zoran Grgantov, Mirjana Milić, Boris Dugonjić

*Faculty of Kinesiology, University of Split*

### Abstract

The aim of this study was to analyse the metric characteristics of 2 tests for assessing agility on sand surface. The study was conducted on a sample of 20 female indoor volleyball players, aged  $14.25 \pm 0.96$  years. The participants were tested using two tests for assessing agility: 6x6 m run and 9-3-6-3-9 m run with 180° turns. Both tests showed good reliability, homogeneity and sensitivity. The 6x6 and 9-3-6-3-9 test can be used to test agility in youth female volleyball players on sand surface.

**Key words:** *beach volleyball, youth female players, 6x6 and 9-3-6-3-9 test, validation*

### 1. Introduction

Beach volleyball is a sport characterized by repeated jumps for attack and block, as well as fast and sudden changes of movement direction (Magalhães et al., 2011). Thus, in the training process involving youth female beach volleyball players, special attention should be paid to the development and control of agility. Although the reactive component of agility is very important in all sports games (Shepard et al., 2006; Oliver et al., 2009; Sekulić et al., 2014), when training young athletes, the emphasis should be put on the development of the motor component of agility, i.e., the development of fundamental skills and change of direction speed (Lloyd et al., 2013; Grgantov et al., 2016). The 6x6 and 9-3-6-3-9 test are often used tests, with validated metric characteristics for testing youth female volleyball players in indoor volleyball, i.e., on firm surface (Morales, 2000; Katić et al., 2006). However, the unlevelled and soft sand requires the players to adapt to the specific conditions (Bishop, 2003).

Thus, the aim of this study was to test the metric characteristics of the 6x6 and the 9-3-6-3-9 test for assessing agility on sand surface.

## 2. Materials and methods

The study was conducted on a sample of 20 female indoor volleyball players, who possess the basic knowledge of volleyball elements, and whose mean age was  $14.25 \pm 0.96$  years.

The participants were tested by using two agility tests: 6x6 m run and 9-3-6-3-9 m run with 180° turns (Morales, 2002; Katić et al., 2006). The measurement was conducted on beach volleyball courts (on sand surface) during morning hours. Before the testing, all participants did a 15-minute warm-up, which included 10 minutes of dynamic stretching and 5 minutes of preliminary agility exercises. The participants repeated each test three times, with adequate recovery periods.

The data were analysed by first calculating the metric characteristics of the tests: Reliability of the measuring instruments was analysed based on the matrix of item intercorrelations. Average inter-item correlation and Cronbach's alpha coefficients were also calculated. Homogeneity of the measuring instruments was obtained based on the analysis of variance between the items, and sensitivity of the measuring instruments was analysed by the Kolmogorov-Smirnov test for determining normality of distribution, as well as by measures of distribution asymmetry and peakedness (SKEW and KURT, respectively).

After testing the metric characteristics of the tests on condensed results, descriptive statistical indicators of the tests were calculated: mean (M), standard deviation (SD), minimum and maximum result (MIN and MAX).

All the data were analysed by the *Statistica Ver.13* software.

## 3. Results and discussion

Reliability of the measuring instruments indicates the amount of error of the measuring instrument and provides information on whether the final result shows the "real" state of the subjects. Reliability of the measuring instruments was analysed based on the matrix of item intercorrelations. Average inter-item correlation and Cronbach's alpha coefficient were also calculated (Table 1).

**Table 1:** Item intercorrelations and values of reliability of coefficients (N = 20)

	9-3-6-3-9 (1)	9-3-6-3-9 (2)	9-3-6-3-9 (3)	CA	IIR
9-3-6-3-9 (1)	1.000	0.420	0.474	0.79	0.609
9-3-6-3-9 (2)	0.420	1.000	0.820		
9-3-6-3-9 (3)	0.474	0.820	1.000		
	6x6 (1)	6x6 (2)	6x6 (3)	CA	IIR
6x6 (1)	1.000	0.719	0.785	0.914	0.787
6x6 (2)	0.719	1.000	0.841		
6x6 (3)	0.785	0.841	1.000		

**Legend:** CA – Cronbach's alpha, IIR – coefficient of average intercorrelation.

High reliability of the tests, obtained by the analysis of item intercorrelation and by the values of reliability coefficients in tests on sand surface, can be seen in Table 1. Somewhat lower reliability was determined for the 9-3-6-3-9 test. Given that this test was performed first, it can be assumed that this is partially due to the participants' different previous experience in beach volleyball. Some participants were not familiar with the movement on sand surface and they needed to adjust to the different movement technique.

As each test in this testing was repeated 3 times, it was important to test the homogeneity of the measuring instrument, i.e., if it measured the same thing in each repetition. Homogeneity of the measuring instruments was obtained based on the analysis of variance between the items (Table 2).

**Table 2:** Analysis of variance between different variable items

	M	SD	F-TEST	p
9-3-6-3-9 (1)	10.945	0.923	0.182	0.834
9-3-6-3-9 (2)	10.885	0.745		
9-3-6-3-9 (3)	10.995	0.920		
	M	SD	F-TEST	p
6x6 (1)	13.820	1.074	2.487	0.097
6x6 (2)	13.745	1.036		
6x6 (3)	14.090	1.179		

**Legend:** M - mean, SD - standard deviation,

The results of the analysis of variance between the items of different variables on sand surface (Table 2) confirm that all the applied motor tests on sand surface were homogenous ( $p > 0.05$ ), which indicates the lack of systematic bias, e.g., learning or fatigue effect. However, one should be careful when coming to this conclusion because it is possible that during the testing both effects were present but could not have been reflected in the obtained results as their effects are of opposite direction (they cancel each other out).

Sensitivity of the measuring instruments indicates how successful the test is in differentiating the participants based on the measurement property. It was analysed by the Kolmogorov-Smirnov test for determining the normality of distribution, as well as by the measures of distribution asymmetry and peakedness (SKEW and KURT, respectively – Table 3).

**Table 3:** Descriptive indicators and sensitivity of the applied variables

	M	MIN	MAX	SD	SKEW	KURT	KS-test*
9-3-6-3-9	10.53	9.40	11.70	0.616	0.272	-0.090	0.12
6x6	13.51	12.30	15.90	0.948	1.040	0.938	0.15

**Legend:** **M** – mean, **Min** - minimum result, **Max** - maximum result, **SD** - standard deviation, **Skew** – coefficient of distribution asymmetry, **Kurt** – coefficient of distribution peakedness. **KS** - Kolmogorov-Smirnov test, \*-cut-off value of the KS-test for N = 20 is 0.30

The values of the KS-test of the applied motor tests for determining agility on sand surface were lower than the cut-off value, which indicates that the measuring variables did not deviate significantly from normal distribution. Moreover, the values of the coefficients of asymmetry and elongation, which ranged from -1 to +1, indicated good sensitivity of the applied test, with emphasis on small positive asymmetry and elongation of the 6x6 test, and mild positive asymmetry and mild flattening of the 9-3-6-3-9 test.

#### 4. Conclusions

Due to the specific movement on sand surface, the agility tests whose metric characteristics have been tested only on firm surface should be validated. In this study, good reliability, homogeneity and sensitivity of two agility tests (6x6 and 9-3-6-3-9) was determined on sand surface. Thus, both tests can be recommended to coaches for the control of development of this motor ability important for success in beach volleyball.



## 5. References

1. Bishop, D. (2003). A comparison between land and sand-based tests for beach volleyball assessment *Journal of Sports Medicine and Physical Fitness*, 43(4), 418-423.
2. Grgantov, Z., Milić, M., & Padulo, J. (2016). Metric characteristics of the Step hop test in young female volleyball players. *Sport Science*, 9(Suppl.2), 82-87.
3. Katić, R., Grgantov, Z., & Jurko, D. (2006). Motor Structures in Female Volleyball Players Aged 14-17 According to Technique Quality and Performance. *Collegium Antropologicum*, 30(1), 103-112.
4. Lloyd, R.S., Oliver, J.L., Meyers, R.W., Read, P., Jeffreys, I., & Nuimphius, S. (2013). Considerations for the development of agility during childhood and Adolescence. *Strength and Conditioning Journal*, 35(3), 2-11.
5. Magalhães J., Inácio M., Oliveira E., Ribeiro J., & Ascensão A. (2011). Physiological and neuromuscular impact of beach-volleyball with reference to fatigue and recovery. *Journal of Sports Medicine & Physical Fitness*, 51, 66-73
6. Morales, J. (2002). Testing issues for volleyball athletes. *Performance volleyball conditioning*, 9(1), 2-3.
7. Oliver, J.L., & Meyers, R.W. (2009). Reliability and generality of measures of acceleration, planned agility, and reactive agility. *International Journal of Sports Physiology and Performance*, 4(3), 345-354
8. Sekulic, D., Krolo, A., Spasic, M., Uljevic, O., & Peric, M. (2014). The development of a new stop'n'go reactive-agility test. *Journal of Strength and Conditioning Research*, 28(11), 3306-3312.
9. Sheppard, J.M., & Young, W.B. (2006). Agility literature review: classifications, training and testing. *Journal of Sports Sciences*, 24(9), 919-932.

## Author Info

Presenting author (student):

Boris Dugonjić

email: [bodugonjic@gmail.com](mailto:bodugonjic@gmail.com)

# Relations of assessment of team cohesion and player positions among young soccer players

Antonio Župan

Faculty of Kinesiology University of Split, Teslina 6, Croatia

## Abstract

*The aim of this study was to determine the relations of assessment of team cohesion and player positions in young soccer players. The subject sample included 114 soccer players from 6 clubs of the South Croatia region, of cadet and junior age group, who are involved in the training process 4 times a week and play 1 competitive match. The variable sample was defined by the items of the Group Environment Questionnaire which includes 4 measures of Cohesion: Group Integration - Social, Group Integration – Task, Individual Attractions to the Group–Social and Individual Attractions to the Group–Task. The result analysis showed that the expressed team Cohesion of young soccer players was at medium level. There were no significant differences players regarding the expressed Cohesion between young soccer players neither according to age group nor player position. It is recommended for coaches to pay more attention and work more on the development of Cohesion in their teams to possibly increase their sport success.*

**Key words:** GEQ, ANOVA, soccer

## 1. Introduction

Today soccer is considered one of the most developed, the best-attended and the most popular sports game in the world. From a relatively simple and attractive game soccer has become „the most important of the less important things in the world“ in a relatively short time period. In the beginning, it all came down to fun and leisure, later on recreational soccer, and ultimately it has become a very serious thing – professional soccer. Soccer is played by children, youth, adults and more and more by women. Soccer is played on almost all surfaces (grass, clay court, asphalt, concrete, parquet, sand), indoors or outdoors (Dujmović, Elsner, & Fiorentini, 2000).

Soccer is a polystructural complex activity composed of multiple, mutually connected but different stereotypical and non-stereotypical motor movement structures of cyclic and acyclic type, which differ in their space-time and dynamic characteristics, and are performed in conditions of cooperation (team-mates) and opposition (players of the other team) that strive for the same goal.

From its creation until today, soccer has changed its rules on several occasions, and thus the structural parts of the game also. Throughout its historical development, it has also changed its demands on the players. What was just fun in the beginning, became playing professional soccer. The criteria of professional soccer are winning or losing.

Soccer is characterized by an active rapport between the coach and the players during a match, and not only during the training process. According to the rules of soccer, the coach is allowed to move around a marked area by the side line and to be actively involved in play by giving advice.

Man, as a social being, satisfies his various biotic and social needs primarily by affiliation to different forms of social groups. The area of social psychology, which studies nature and the rules of formation and development of social groups, their relation towards individuals, other groups and larger institutions, is called group dynamics.

Microsociology is a subdiscipline of social psychology that deals with the study of small social groups (G. Marković, & M. Marković, 2004). A relatively small number of players (11) that play on a large field indicates the importance of the role of each individual in forming group properties in soccer play.

Cohesion is considered the most important component in studying small groups, including sports teams (Golombievski 1962., Lott & Lott, 1965., in Carron et al., 2012).

The term cohesion is derived from the Latin word *cohaesus*, which means "to cleave or stick together". This meaning underlies all definitions of cohesion in social psychology. In sport psychology, the definition which served as a basis for numerous studies, was set by Carron in 1982, and was slightly modified by Carron and Dennis in 1998. According to that definition, cohesion is a dynamic process that is reflected in the tendency for a group to stick together and remain united in the pursuit of its instrumental objectives and/or for the satisfaction of member affective needs. This definition emphasizes 4 components of cohesiveness: Multidimensionality (there are numerous factors that cause a

group to remain united), Dynamic (level of cohesion can vary across time), Instrumental (teams have a reason to stick together, to achieve common goals) and Affective (team members stay together because of mutual friendship and companionship).

When investigating group properties in sport, one should consider that sports teams are dynamic systems which go through different development phases. It can be assumed that in younger age groups, due to the shorter time spent together, the social component of cohesion will be less prominent in relation to the teams that have been part of roughly the same set-up for a long period of time.

Paskevich et al. (2001) state that cohesion has been investigated from different aspects. Regarding external factors, cohesion has been analysed in relation to the team's level of competition and the number of team members. Personal factors such as the difference in the amount of effort athletes extend in the group and when alone, commitment to team goals and coach's behaviour and decision making have also been the subject of researchers' interest.

The most commonly used questionnaire for assessing cohesion is the "Group environment Questionnaire – GEQ" (Carron et al., 1985). The construction and validation of the questionnaire had several phases. Based on the interviews with 234 athletes, and based on the review of previous research (phase one), the items of the questionnaire were selected in phase two. In the following phase, the experts refined the items which were then given to athletes from different sports to answer in the final phase. The overall result was the final version of the questionnaire including 18 items on a 5-point Likert scale (1 – I strongly disagree, 5 – I completely agree), constructed by Milavić (2013).

The aim of this study was to determine the relations of team cohesion and player positions in young soccer players.

## 2. Materials and methods

The subject sample included 114 soccer players from 6 clubs of the South Croatia region, of cadet and junior age groups, that are involved in the training process 4 times a week and play 1 competitive match.

The variable sample was defined by the items of the *Group Environment Questionnaire* (Carron et al., 1985), which is composed of 4 measures of *Cohesion*:

*Group Integration - Social, Group Integration – Task, Individual Attractions to the Group–Social and Individual Attractions to the Group–Task.*

Methods of data analysis included calculation of descriptive parameters and use of univariate analysis of differences – ANOVA to determine the differences between players positions and age groups.

All the data were analysed by the *Statistica Ver.13* software.

### 3. Results and discussion

The results of descriptive parameters of the used *Cohesion* questionnaire are presented in Table 1.

**Table1.** Descriptive parameters of groups of soccer players according to the *expressed Cohesion*

VARIABLE	M	MIN	MAX	SD	SKEW	KURT	KS-test*
GI SOCIAL	3.12	1.50	5.00	0.79	0.35	-0.04	0.11
GI TASK	3.17	1.40	5.00	0.73	0.26	-0.01	0.12
ATG TASK	3.40	1.50	5.00	0.85	0.02	-0.72	0.09
ATG SOCIAL	3.74	1.80	5.00	0.76	-0.36	-0.51	0.10

**Legend:** M - mean; SD - standard deviation; D – coefficient of the K-S test; MIN - minimum result; MAX - maximum result; SKEW – measure of distribution asymmetry; KURT – measure of distribution shape. **KS** - Kolmogorov-Smirnov test, \*-cut-off value of the KS-test for N = 114 is 0.13

By analyzing Table 1, it can be seen that cohesion in the teams was at medium level: *Individual Attractions to the Group (ATG)* was considerably higher than the real (actual, perceived) group integration; the lowest measure was *Group Integration – Social* (3.12), and the highest was *Individual Attractions to the Group – Social* (3.74).

This shows that young players show higher readiness to socialize with their teammates than they actually do socialize. This indicates that young players “use” or “have” some other groups of peers for socializing. It can be assumed that this refers to classmates or peers from their neighbourhood.

None of the results of the used variables deviated significantly from normal distribution (K-S test=0.13), thus, the use of parametric methods of data analysis is permitted in further analysis.

The results of analysis of differences between soccer players of different age groups according to the *expressed Cohesion* are presented in Table 2.

**Table 2.** Analysis of variance of groups of soccer players of different age groups according to the *expressed COHESION*

VARIABLES	AGE GROUPS						F	p
	Year of birth 98 and 99 N-48		Year of birth 97 N-29		Year of birth 96 and 95 N-37			
	M	SD	M	SD	M	SD		
GI SOCIAL	3.41	0.91	3.34	0.86	3.43	0.78	0.08	0.92
GI TASK	3.69	0.78	3.76	0.71	3.78	0.80	0.16	0.85
ATG TASK	3.19	0.80	2.97	0.62	3.29	0.71	1.59	0.21
ATG SOCIAL	3.15	0.90	2.96	0.63	3.22	0.76	0.95	0.39

**Legend:** M - mean; SD - standard deviation; F – coefficient of analysis of variance; p – level of statistical significance.

It can be seen from Table 2 that there were no significant differences in the measures of *Cohesion* between the age groups of players. Thus, regardless of their chronological age, players have very similar perceptions of cohesion and individual attractions to the group.

The results of analysis of differences according to the *expressed Cohesion* between young soccer players at different player positions are presented in Table 3.

**Table 3.** Analysis of variance of groups of soccer players at different player positions according to the *expressed COHESION*

VARIABLES	PLAYER POSITIONS								F	p
	GOALKEEPERS N-7		DEFENDERS N-37		MIDFIELDERS N-41		FORWARDS N-29			
	M	SD	M	SD			M	SD		
GI SOCIAL	3.14	0.75	3.52	0.89	3.38	0.82	3.34	0.87	0.52	0.67
GI TASK	3.31	0.74	3.78	0.71	3.76	0.80	3.76	0.78	0.77	0.51
ATG TASK	3.09	0.55	3.04	0.79	3.33	0.71	3.12	0.72	1.09	0.35
ATG SOCIAL	2.64	0.59	3.06	0.87	3.22	0.85	3.18	0.62	1.19	0.32

**Legend:** M - mean; SD - standard deviation; F – coefficient of analysis of variance; p – level of statistical significance.

Cohesion between the groups of players according to player position. Thus, regardless of their chronological age, players have very similar perceptions of cohesion and individual attractions to the group.

The following *post-hoc analysis* determined that there were no significant differences after all between the goalkeepers and the midfielders and the forwards according to their individual attractions to the group, i.e., social-wise, they want to have a social group outside the team itself.

#### 4. Conclusions

Based on the aim of this paper, it can be concluded that team *Cohesion* of young soccer players was at medium level. There were no significant differences in the expressed *Cohesion* between young soccer players neither according to age group nor player position.

It is recommended for the coaches to pay more attention and work on the development of *Cohesion* in their teams in order to possibly increase the teams' sports success.

#### 5. References

1. Carron, A.V. (1982). Cohesiveness in sport groups: implications and considerations. *Journal of Sport Psychology*, 4, 123-138.
2. Carron, A.V. (1988). *Group dynamics in sport*. London, Ontario: Spodym.
3. Carron, A.V., & Dennis P.W. (1998). The sport team as a effective group. In: J.M. Williams (Ed). *Applied sport psychology: personal growth to peak performance*, 3rd ed. Mountain View Calif.: Mayfield. 127-141.
4. Carron, A.V., Widmeyer, W.N., & Brawley, L.R. (1985). The Development of an Instrument to Assess Cohesion in Sport Teams: The Group Environment Questionnaire, *Journal of Sport Psychology*, 7, 244-266.
5. Dujmović , P., Elsner, B., Fiorentini, F. (2000). *Škola nogometa*. Zagreb: Zagrebački nogometni savez.
6. Marković, G., & Marković, M. (2004). Procjena elastične snage u sportu. U: V. Findak (ur.). *Zbornik radova 13. Ljetne škole pedagoga fizičke kulture RH* (str. 135-138), Hrvatski Kineziološki savez, Zagreb.
7. Milavić , B. (2013). *Construction and validation of the questions psychological*

---

*characteristics*. [Doctoral thesis]. Split: University of Split, Faculty of Kinesiology

8. Paskevich D.M., Estabrooks P.A., Brawley L.R., & Carron A.V. (2001). Group Cohesion in Sport and Exercise. In: Singer R.N., Hausenblas H.A., & Janelle C.M. (Eds), *Handbook of sport psychology, 2nd ed.* John Wiley & Sons Inc, New York. 239-268.

### **Author Info**

Antonio Župan

email: [antonio.zupan@gmail.com](mailto:antonio.zupan@gmail.com)



**TOP 20 CONFERENCE PAPERS PUBLISHED IN ACTA  
KINESIOLOGICA JOURNAL (Vol. 11. Issue 2.) WHICH IS  
INDEXED IN THOMSON REUTERS DATABASE:**

*Biljana Kuzmanić, Nina Ivančić, Jelena Paušić*

Test-retest reliability of the 36-Item Health Survey (SF-36) as Quality of Life Measures in Elderly Croatian Population

*Ana Zovko, Nedim Šišić, Nataša Zenić*

The relationship between sports participation and cigarette smoking in adolescents; preliminary results of a prospective cohort study

*Marko Šimac, Zoran Grgantov, Mirjana Milić*

Situational efficacy of top croatian senior beach volleyball players

*Dean Kontić, Đivo Ban, Šime Veršić*

Reliability and discriminative validity of novel method in evaluation of water polo performance for cadet-age players

*Giuseppe Penna, Luca Russo, Paolo Bartolucci*

Effects of two training protocols on the strength of the medius and maximus gluteus in adult women

*Tea Bešlija, Dragan Marinković, Dražen Čular*

Postural stability assessment in elite taekwondo athletes: comparative study between different age groups

*Teodora Miketa, Nina Ivančić, Biljana Kuzmanić*

Relationship of breathing exercises with improvement of postural stability in healthy adults

*Mia Perić, Hrvoje Plazibat, Ivana Dabo*

Sport factors and alcohol consumption among adolescents on island brač

*Katija Kovačić, Duje Petričević, Dražen Čular*

Sport entrepreneurship, education and secondary career

*Sunčica Delaš Kalinski, Igor Jelaska, Nikolina Knezević*

Age effects among elite male gymnasts

*Igor Jelaska, Sunčica Delaš Kalinski, Tina Crnjak*

Chronological age among Olympic Women's Artistic Gymnastics. Does it really matter?

*Nebojša Trajković, Tomislav Krstičević, Goran Sporiš*

Small-sided Games vs. Instructional Training for Improving Skill Accuracy in Young Female Volleyball Players

---

*Saša Krstulović, Goran Kuvačić, Marko Erceg*

Morphological, functional and dynamical asymmetry in female judokas

*Ante Rađa, Marc Collignon Simó, Marko Erceg*

Relative age effect in top level European soccer leagues

*Danijela Kuna, Josip Maleš, Damir Bavčević*

Methodical model for correction of a common mistake in the Snow plow bow turn performance

*Alen Miletić, Boris Milavić, Noemi Zovko*

Body Image and Motivation Importance in Successful Standard Dances Performance

*Dejan Madić, Goran Sporiš, Ana Kezić*

Reliability and usefulness of bulb dynamometer for measuring hand grip strength in preschool children

*Goran Kuvačić, Johnny Padulo, Mirjana Milić*

Smith Machine exercise: the key points

*Goran Gabrilo, Ante Orlović, Matej Miličić*

What makes greater impact on the swimming results, gliding elements or swimming elements?

*Mirjana Telebuh, Gordana Grozdek Čovčić, Snježana Schuster*

Physiotherapy and recreation in spinal cord injury – a case study

**SPONSORS**

